

QUANTUM *Series*

Semester - 5 Civil Engineering

Geotechnical Engineering



Includes **MCQ**

- Topic-wise coverage of entire syllabus in Question-Answer form.
- Short Questions (2 Marks)

Session
2021-22
Odd Semester

Includes solution of following AKTU Question Papers

2015-16 • 2016-17 • 2017-18 • 2018-19 • 2019-20 • 2020-21

QUANTUM SERIES

For
B.Tech Students of Third Year
of All Engineering Colleges Affiliated to
Dr. A.P.J. Abdul Kalam Technical University,
Uttar Pradesh, Lucknow
(Formerly Uttar Pradesh Technical University)

GEOTECHNICAL ENGINEERING

By
Rustam Ali

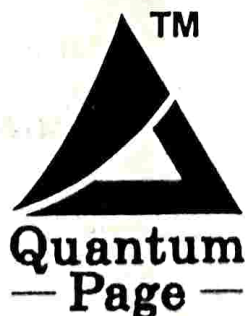

QUANTUM PAGE PVT. LTD.
Ghaziabad ■ New Delhi

PUBLISHED BY :

Apram Singh
Quantum Publications®
 (A Unit of Quantum Page Pvt. Ltd.)
 Plot No. 59/2/7, Site - 4, Industrial Area,
 Sahibabad, Ghaziabad-201 010

Phone : 01 20 - 4160479

Email : pagequantum@gmail.com

Website: www.quantumpage.co.in

Delhi Office : J6590, East Rohas Nagar, Shahdara, Delhi-110032

© ALL RIGHTS RESERVED
 No part of this publication may be reproduced or transmitted,
 in any form or by any means, without permission.

Information contained in this work is derived from sources believed to be reliable. Every effort has been made to ensure accuracy, however neither the publisher nor the authors guarantee the accuracy or completeness of any information published herein, and neither the publisher nor the authors shall be responsible for any errors, omissions, or damages arising out of use of this information.

Geotechnical Engineering (CE : Sem-5)

- 1st Edition : 2014-15
 2nd Edition : 2015-16
 3rd Edition : 2016-17
 4th Edition : 2017-18
 5th Edition : 2018-19
 6th Edition : 2020-21 (Thoroughly Revised Edition)
 7th Edition : 2021-22

Price: Rs. 125/- only

Printed at : Mayank Enterprises, Delhi-110093.

CONTENTS

KCE-501 : GEOTECHNICAL ENGINEERING

- UNIT-1 : ORIGIN AND CLASSIFICATION** (1-1 A to 1-34 A)
 Preview of Geotechnical field problems in Civil Engineering, Soil formation, transport and deposit, Soil composition, Basic definitions, Weight volume relationships, Clay minerals, Soil structure, Index properties, sensitivity and thixotropy, Particle size analysis, Unified and Indian standard soil classification system.
- UNIT-2 : SOIL HYDRAULICS** (2-1 A to 2-32 A)
 Stress conditions in soil - total, effective and neutral stresses and relationships. Permeability - Darcy's Law, hydraulic conductivity, equivalent hydraulic conductivity in stratified soil. Seepage, flow nets, seepage calculation from a flow net, flow nets in anisotropic soils, seepage through earth dam, capillarity, critical hydraulic gradient and quick sand condition, uplift pressure, piping.
- UNIT-3 : SOIL COMPACTION & CONSOLIDATION** (3-1 A to 3-30 A)
 Soil compaction, water content - dry unit weight relationships. Factors controlling compaction. Field compaction equipment, field compaction control, Proctor needle method, Consolidation: Primary and secondary consolidation, Terzaghi's one dimensional theory of consolidation, Consolidation test, Normal and Over Consolidated soils, Over Consolidation Ratio, determination of coefficient of consolidation.
- UNIT-4 : STRESS DISTRIBUTION IN SOIL** (4-1 A to 4-34 A)
 Stress Distribution in soil: Elastic constants of soils and their determination, Boussinesq equation for vertical stress, The Westergaard equation, Stress distribution under loaded areas, Concept of pressure bulb, contact pressure. Shear Strength: Mohr-Coulomb failure criterion, shear strength parameters and determination; direct and tri-axial shear test; unconfined compression test; pore pressure, Skempton's pore pressure coefficients, and Soil liquefaction.
- UNIT-5 : EARTH PRESSURE & STABILITY OF SLOPES** (5-1 A to 5-28 A)
 Earth pressure: Classical theories, Coulomb and Rankine's approaches for frictional and c-φ soils, inclined backfill, Graphical methods of earth pressure determination.
 Stability of slopes - finite and infinite slopes, types of slope failure, Culmann's method & Method of slices, Stability number & chart, Bishop's method.
- SHORT QUESTIONS** (SQ-1 A to SQ-16 A)
- SOLVED PAPERS (2015-16 TO 2020-21)** (SP-1 A to SP-23 A)
- MULTIPLE CHOICE QUESTIONS** (MCQ-1A to MCQ-32A)

Origin and Classification of Soil

CONTENTS

- Part-1 :** Preview of Geotechnical Field 1-2A to 1-10A
 Problems in Civil Engineering
 Soil Formation,
 Transport and Deposit,
 Soil Composition, Basic Definitions,
 Weight-Volume Relationships
- Part-2 :** Clay Minerals, Soil Structure 1-19A to 1-33A
 Index Properties, Sensitivity
 and Thixotropy, Particle Size Analysis,
 and Unified and Indian
 Standard Soil Classification System

PART-1

*Preview of Geotechnical Field Problems in Civil Engineering,
 Soil Formation, Transport and Deposit, Soil Composition,
 Basic Definitions, Weight-Volume Relationships.*

Questions-Answers

Long Answer Type and Medium Answer Type Questions

Que 1.1. What is Geotechnical Engineering ? Give its use.

Answer

- A. Geotechnical Engineering :**
1. Geotechnical engineering is a part of Civil Engineering that deals with the study and investigation of earth materials.
 2. This branch of engineering uses principles of soil and rock mechanics to investigate and study subsurface materials and conditions.
- B. Use :** Following are the uses of geotechnical engineering in various field :
1. Foundation design and construction.
 2. Pavement design.
 3. Design of underground earth retaining structure.
 4. Design of embankments and excavation.
 5. Design of earth dams.

Que 1.2. What do you understand by residual soil and transported soil ?

OR

Differentiate between residual soil and transported soil.

Answer

S.No.	Residual Soil	Transported Soil
1.	Residual soils are soils that are found at the same location where they have been formed.	Any soil that has been transported from its place of origin by wind, water, ice or any other agency and has been redeposited is called a transported soil.
2.	These soils are generally stiff and stable.	Many of these soils are loose and soft upto a fixed depth.

Que 1.3 Explain different types of transported soil.

Answer

Types of Transported Soils : Following are the various types of transported soil :

1. **Water Transported Soils :** Flowing water carries a large quantity of soil either in suspension or by rolling along the bed. All type of soils carried and deposited by water are known as **alluvial deposits**. Deposits made in lakes are called **lacustrine deposits**.
2. **Wind Transported Soils :** Soil particles are transported by winds. Soils deposited by wind are known as **aeolian deposits**. Loess is a silt deposit made by wind.
3. **Glacier-Deposited Soils :** As the glaciers melt and recede, material contained in the ice is deposited on the ground leading to formation of glacial deposits.
4. **Gravity-Deposited Soils :** Soils can be transported under the action of gravity. Colluvial soils, such as talus, have been deposited by the gravity.

Que 1.4 Explain the major groups of soil deposits in India.

Answer

The soil deposits in India may be classified in the following five major groups :

1. **Alluvial Deposits :**
 - i. A large part of North India is covered with alluvial deposits.
 - ii. The thickness of alluvium in the Indo-Gangetic and Brahmaputra flood plains varies from a few metres to more than one hundred metres.
2. **Black Cotton Soils :**
 - i. A large part of Central India and a portion of South India is covered with black cotton soils.
 - ii. These soils are residual deposits formed from basalt or trap rocks. The soils are quite suitable for growing cotton.
3. **Lateritic Soils :** Lateritic soils are formed by decomposition of rock, removal of bases and silica, and accumulation of iron oxide and aluminum oxide. The presence of iron oxide gives these soils the characteristics red or pink colour.
4. **Desert Soils :** A large part of Rajasthan and adjoining states is covered with sand dunes. In this area, arid condition exists, with practically little rainfall.
5. **Marine Deposits :** Marine deposits are mainly confined along a narrow belt near the coast. In the south-west coast of India, there are thick layers of sand above deep deposits of soft marine clays.

Que 1.5 What are the three basic factors which influence the characteristics of a transported soil ? What factors determine the characteristics of a residual soil ?

Answer

A. Basic Factors for Transported Soil :

Table 1.5.1. Effects of transportation on sediments.

Characteristics	Water	Air	Ice	Gravity	Organisms
Size	Reduction through solution, little abrasion in suspended load, some abrasion and impact in traction load	Considerable reduction	Considerable grinding and impact	Considerable impact	Minor abrasion effects from direct organic transportation
Shape and roundness	Rounding of sand and gravel	High degree of rounding	Angular, solid particles	Angular, non-spherical	
Surface texture	Sand: smooth, polished, shiny	Impact produces frosted surfaces	Striated surfaces	Striated surfaces	
Sorting	Considerable sorting	Very considerable sorting (progressive)	Very little sorting	No sorting	Limited sorting

B. Factors Determine the Characteristics of a Residual Soil :

Residual soils are products of chemical weathering and thus their characteristics are dependent upon environmental factors of climate, raw materials, parent material, topography and drainage, flow and age.

Que 1.6 What do you mean by soil composition ?

Answer

1. Soil is a complex physical system consisting of different phases.
2. The term phase means any homogeneous part of the system different from other parts of the system and separated from them by abrupt transition.
3. A mass of soils includes accumulated solid particles or soil grains and the void spaces existing between the particles.
4. The void spaces may be partially or completely filled with water or some other liquid, and those not occupied by water or any other liquid are filled with air or some other gas.
5. The soil mass generally consist a three phase system like soil (solid), water (liquid) and air (gas).

6. The three constituents of a soil mass do not occupy separate spaces but are blended together forming a complex material as shown in Fig. 1.6.1(a).
7. When the soil voids are completely filled with water, the gaseous phase being absent, the soil is said to be 'fully saturated' or 'merely saturated'.

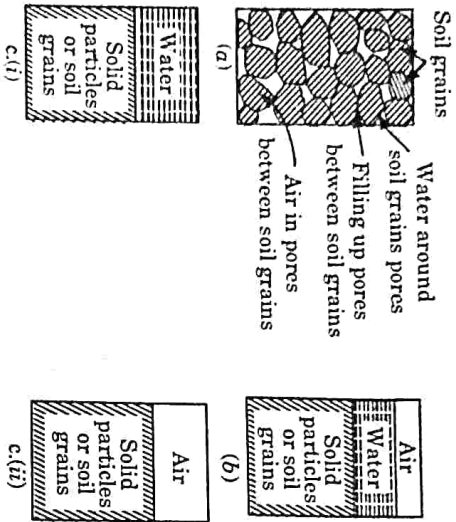

Fig. 1.6.1. (a) Actual soil mass, (b) Representation of soil mass by three-phase diagram.

8. When there is no water at all in the voids, the voids will be full of air, the liquid phase being absent, the soil is said to be dry.
9. In both these cases, the soil system reduces to a two-phase system as shown in Fig. 1.6.1(c).

Que 1.7. Define the basic terms which are related to soil system.

OR

Define void ratio, bulk unit weight and specific gravity.

AKTU 2016-17, Marks 02

Answer

Following are the basic terms which are related to soil system :

1. **Void Ratio (e) :**
It is defined as the ratio of the volume of voids to the volume of solids.
Thus

$$e = \frac{V_v}{V_s}$$

- ii. For coarse-grained soils, the void ratio is generally smaller than for fine-grained soils. For some soils, it may have a value even greater than unity.

2. **Porosity (n) :**
It is defined as the ratio of the volume of voids to the total volume of soil.
Thus

$$n = \frac{V_v}{V}$$

- ii. The porosity of a soil cannot exceed 100% as it would mean V_v is greater than V , which is absurd. Porosity is also known as percentage voids.
3. **Degree of Saturation (S) :**
The degree of saturation (S) is the ratio of the volume of water to the volume of voids,

$$S = \frac{V_w}{V_v}$$

- ii. It is equal to zero when the soil is absolutely dry and 100% when the soil is fully saturated.
4. **Percentage Air Voids (n_a) :** It is the ratio of the volume of air to the total volume of soil.

$$n_a = \frac{V_a}{V}$$

5. **Air Content (a_c) :**
It is defined as the ratio of the volume of air to volume of voids.

$$a_c = \frac{V_a}{V_v}$$

- ii. Both air content and the percentage air voids are zero when the soil is saturated ($V_a = 0$).
6. **Water Content (w) :** It is defined as the ratio of the mass of water to the mass of solids.

$$w = \frac{M_w}{M_s}$$

The water content of some of the fine-grained soils may be even more than 100%, which indicates that more than 50% of the total mass is that of water.

7. **Bulk Unit Weight :**

The bulk unit weight (γ) is defined as the total weight per unit total volume. Thus

$$\gamma = \frac{W}{V}$$

- ii. The bulk unit weight is also known as the total unit weight (γ_t), or the wet unit weight.

8. **Dry Unit Weight (γ_d) :** It is defined as the weight of solids per unit total volume. Thus

$$\gamma_d = \frac{W_s}{V}$$

9. **Saturated Unit Weight (γ_{sat})** : It is the bulk unit weight when the soil is fully saturated.

Thus
$$\gamma_{sat} = \frac{W_{tot}}{V}$$

10. **Submerged Unit Weight (γ')** : The submerged unit weight of the soil is defined as the submerged weight of soil per unit of total volume.

Thus
$$\gamma' = \frac{W'_{tot}}{V}$$

11. **Specific Gravity of Solids** : The specific gravity of solid particles (G) is defined as the ratio of the mass of a given volume of solids to the mass of an equal volume of water at 4°C. Thus, the specific gravity is given by,

$$G = \frac{\rho_s}{\rho_w}$$

The mass density of water ρ_w at 4°C is 1 gm/ml, 1000 kg/m³ or 1 Mg/m³.

Que 1.8. Derive the relationship between :

- A. 'e' and 'n'.
- B. e, u, S, G .
- C. $\gamma, \gamma_d, \gamma_{sat}$ and γ' .
- D. n, e and S .
- E. $\gamma_d, \gamma, n, e, u$ and G .

AKTU 2017-18, Marks 05

OR
Prove that dry unit weight of soil

$$\gamma_d = \frac{(1-n_u)G\gamma_w}{1+e}$$

AKTU 2019-20, Marks 07

Answer

A. Relationship Between 'e' and 'n':

1. We have void ratio, $e = \frac{V_v}{V_s}$
and porosity, $n = \frac{V_v}{V}$
where, V_v = Volume of voids, V_s = Volume of solids, V = Total volume of soil sample

$$n = \frac{V_v}{V_s + V_s} = \frac{V_v}{V_s} \times \frac{V_s}{V_s + V_s}$$

$$\frac{V_v + V_s}{V_s} = \frac{1}{n}$$

$$\frac{V_v}{V_s} + \frac{V_s}{V_s} = \frac{1}{n}$$

$$3. \frac{1}{e} + 1 = \frac{1}{n}$$

$$\frac{e}{1+e} = \frac{1}{n}$$

Porosity,
$$n = \frac{e}{1+e}$$

B. Relationship Between e, w, S, G :

1. Void ratio,

$$e = \frac{V_v \times \frac{V_w}{V_s}}{\frac{V_s}{V_s}} = \frac{1}{S} \frac{V_w}{V_s}$$

$$\left[\because \frac{V_w}{V_s} = S \right]$$

...(1.8.1)

2. We know that,

$$\gamma_w = \frac{W_w}{V_w}, \quad G = \frac{\gamma_s}{\gamma_w} = \frac{W_s}{V_s \gamma_w}$$

3. Put the above value eq. (1.8.1), we get

$$e = \frac{1}{S} \left(\frac{W_w}{\gamma_w} \right) \left(\frac{G \gamma_w}{W_s} \right)$$

$$\left[\because w = \frac{W_w}{W_s} \right]$$

$$e = \frac{1}{S} w G$$

where,

$Se = wG$

S = Degree of saturation.

e = Void ratio.

w = Water content.

G = Specific gravity of soil solids.

Relationship Between $\gamma, \gamma_d, \gamma_{sat}$ and γ' :

1. Bulk unit weight,
$$\gamma = \frac{W}{V} = \frac{W_s + W_w}{V}$$

(W_s = Weight of solids, W_w = Weight of water)

$$2. \gamma = \frac{V_s \gamma_s + V_w \gamma_w}{V_u + V_s}$$

$$\frac{V}{V_s} = \frac{V_u}{V_s} + \frac{V_s}{V_s}$$

$$\frac{V}{V_s} = e + 1$$

$$V = V_s (1+e)$$

$$\gamma = \frac{W_s + W_w}{V_s (1+e)}$$

$$\gamma = \frac{G V_s \gamma_w + \gamma_w V_w}{V_s (1+e)}$$

$$\gamma = \frac{\gamma_w \left[G + \frac{V_w}{V} \times \frac{V_c}{V_s} \right]}{1+e}$$

$$\gamma = \left(\frac{G + Se}{1+e} \right) \gamma_w$$

1. If soil is dry, then

$$\gamma = \gamma_d \quad \text{and} \quad S = 0$$

$$\gamma_d = \frac{G \gamma_w}{1+e}$$

3. If soil is fully saturated, then

$$\gamma = \gamma_{sat} \quad \text{and} \quad S = 1$$

$$\gamma_{sat} = \left(\frac{G+e}{1+e} \right) \gamma_w$$

$$\gamma_{sat} - \gamma_d = \gamma_w$$

$$\gamma = \left(\frac{G+e}{1+e} \right) \gamma_w - \gamma_w$$

$$\gamma = \left(\frac{G-1}{1+e} \right) \gamma_w$$

D. Relation Between n , e , and S :

1. We have

$$V = V_a + V_w + V_s$$

2. Dividing by V

$$1 = \frac{V_a}{V} + \frac{V_w}{V} + \frac{V_s}{V}$$

$$1 = n_a + \frac{W_w}{\gamma_w V} + \frac{W_s}{\gamma_s V}$$

$$(1 - n_a) = \frac{W_w}{\gamma_w V} + \frac{W_s}{\gamma_s V}$$

$$= \frac{W \gamma_d + W_s \gamma_d}{\gamma_w G \gamma_w} \quad \dots(1.8.2)$$

3. We know that

$$\frac{G \gamma_w}{\gamma_d} = 1 + e$$

4. Putting in eq. (1.8.2), we get

$$(1 - n_a) = \frac{Gw}{1+e} + \frac{1}{1+e}$$

$$1 - n_a = \frac{Se}{1+e} + \frac{1}{1+e}$$

$$n_a = \frac{e(1-S)}{1+e}$$

$$\therefore Se = Gw$$

E. Relation Between γ_d , γ , n , w and G :

1. Water content,

$$w = \frac{W_w}{W_s}$$

2.

$$1 + w = 1 + \frac{W_w}{W_s} = \frac{W_s + W_w}{W_s} = \frac{W}{W_s}$$

$$W_s = \frac{W}{(1+w)}$$

3. Dry unit weight, $\gamma_d = \frac{W_s}{V} = \frac{W}{(1+w)V}$

$$\gamma_d = \frac{\gamma}{(1+w)}$$

We know that

$$V = V_a + V_w + V_s$$

Dividing by V ,

$$1 = \frac{V_a}{V} + \frac{V_w}{V} + \frac{V_s}{V}$$

$$1 = n_a + \frac{W_w}{\gamma_w V} + \frac{W_s}{\gamma_s V}$$

$$(1 - n_a) = \frac{W_w}{\gamma_w V} + \frac{W_s}{\gamma_s V}$$

$$= \frac{W W_s}{\gamma_w V} + \frac{\gamma_d}{\gamma_s V}$$

$$= \frac{w \gamma_d + \gamma_d}{\gamma_w G \gamma_w}$$

$$(1 - n_a) = \left(w + \frac{1}{G} \right) \frac{\gamma_d}{\gamma_w}$$

$$\gamma_d = \frac{(1 - n_a) G \gamma_w}{1 + wG}$$

Que 1.9. Discuss various field and laboratory methods of water content determination of soils.

Answer

Water content of soil can be determined by any of the following method:

A. Oven Dry Method:

1. This method is a standard, laboratory method.

2. In this method, water content is computed in following steps:

- i. Moist sample of soil whose moisture content is to be determined is placed in an empty container of weight (M_1).
- ii. Let the weight of container with moist soil sample be (M_2).
- iii. The container with moist soil is placed in a temperature control oven for drying at the temperature of $110 \pm 5^\circ\text{C}$.
- iv. For inorganic soil like sand drying is require for 4 hours and for clays and silt drying is require for 12-16 hours.
- v. After drying weight of container with dry soil is noted (M_3).

And now,

$$\text{Water content, } w = \frac{M_2 - M_3}{M_3 - M_1} \times 100$$

B. Sand Bath Method :

1. This is a field method for determination of water content.
2. A sand bath is large open vessel containing sand filled to a depth of 5 cm or more.
3. The soil is taken in a tray. It is crumbled. A few pieces of white paper are also kept on the sample.
4. Mass of wet sample is obtained by weighing the tray.
5. The tray is then placed on sand bath.
6. The sand bath is heated over a stove.
7. During heating, the sample is turned with a palette knife. Overheating of soil should be avoided. The white paper turns brown when overheating occurs.
8. When drying is complete, the tray is removed, cooled and weighted.
9. The water content is determined by,

$$w = \frac{M_w}{M_s} \times 100\%$$

C. Alcohol Method :

1. The sample is broken, crumbled and taken in an evaporating dish.
2. The mass of wet sample is taken (M_1).
3. The sample is then mixed with alcohol.
4. About one millilitre of alcohol is added for every gram of soil.
5. The alcohol is then ignited. The mixture is turned with spatula when ignition is taken place.
6. After the alcohol is burnt away completely, the dish is allowed to cool and mass of dry soil is obtained (M_2).
7. Water content is found out as follows :

$$w = (M_1 - M_2) / M_2 \times 100.$$

8. This method cannot be used if the soil contains large proportion of organic matter, gypsum and any other calcareous materials.

D. Calcium Carbide Method :

1. This method can be used in the field and in the laboratory too.
2. The instrument used is known as rapid moisture tester.
3. This method makes use of fact that when water reacts with calcium carbide, acetylene gas is generated.
4. The acetylene gas produced exerts pressure and it is recorded in the dial gauge attached to the moisture tester.
5. The soil sample of 6 grams is taken in the test cylinder containing calcium carbide.
6. The soil sample is required to be ground and pulverized.
7. The quantity of gas produced is indicated on the dial gauge in terms of pressure.
8. From the calibrated scale of pressure gauge, the moisture content based on total mass is determined.
9. The water content (w) based on dry mass is calculated as,

$$w = \left(\frac{W}{100 - W} \right) \times 100\%$$

where, W = Weight of sample.

Que 1.10. An oven dry soil sample of volume 250 cc weight 430 g. If the specific gravity of solids is 2.70, what is the water content when the soil becomes fully saturated without any change in its volume? What will be the water content which will fully saturate the sample and also cause an increase in volume equal to 10 % of the original dry volume ?

AKTU 2017-18, Marks 05

Answer

Given : Volume of sample, $V = 250$ cc, Weight of sample = 430 gm, Specific gravity, $G = 2.70$

To Find : Water content for fully saturation without any change in volume and increase 10 % volume of original dry volume.

1. We know that, $\gamma_d = \frac{M_s}{V}$

$$\gamma_d = \frac{430}{250} = 1.72 \text{ gm/cc}$$

2. And,

$$\gamma_d = \frac{G\gamma_w}{1+e} \quad \therefore \gamma_w = 1 \text{ gm/cc}$$

$$1+e = \frac{2.7 \times 1}{1.72}$$

$$e = 1.57 - 1 = 0.57 \text{ or } 57\%$$

3. Also we know that,

$$S \times e = wG$$

$$w = \frac{0.57 \times 1}{2.7} = 0.21 \text{ or } 21\%$$

4. New volume of the soil,

$$V = 1.1 \times 250 = 275 \text{ cc}$$

5. New dry unit weight,

$$\gamma_d = \frac{430}{275} = 1.564 \text{ gm/cc}$$

6. New void ratio,

$$1+e = \frac{G\gamma_w}{\gamma_d} = \frac{2.7 \times 1}{1.564}$$

$$e = 1.73 - 1 = 0.73 \text{ or } 73\%$$

7. But,

$$S \times e = wG$$

$$(\because S = 1)$$

$$\text{New water content, } w = \frac{0.73}{2.7} = 0.27 \text{ or } 27\%$$

Que 1.11. A partially saturated sample from a borrow pit has a natural moisture content of 15% and bulk unit weight of 1.9 g/cc. The specific gravity of solids is 2.70. Determine the degree of saturation and void ratio. What will be the unit weight of the sample on saturation?

Answer

Given : Water content, $w = 0.15$, Bulk unit weight, $\gamma = 1.9 \text{ gm/cc}$
Specific gravity, $G = 2.7$

To Find : Degree of saturation and void ratio, Unit weight of the sample on saturation.

1. We know that,

$$S \times e = G \times w$$

$$S \times e = 2.7 \times 0.15$$

$$S \times e = 0.405$$

$$\dots(1.11.1)$$

2. Bulk unit weight of soil is given by, $\gamma = \left(\frac{G + S \times e}{1 + e} \right) \gamma_w$

$$1.9 = \left(\frac{2.7 + 0.405}{1 + e} \right) \times 1$$

Void ratio,

$$e = 0.634.$$

3. Now, put the value of $e = 0.634$ in eq. (1.11.1).

$$S = \frac{0.405}{0.634} = 0.638$$

Degree of saturation, $S = 63.8\%$.

4. Saturated weight of soil is given by,

$$\gamma_{\text{sat}} = \left(\frac{G + e}{1 + e} \right) \gamma_w = \left(\frac{2.7 + 0.634}{1 + 0.634} \right) \times 1$$

$$\text{Saturated unit weight, } \gamma_{\text{sat}} = 2.04 \text{ gm/cm}^3$$

Que 1.12. The specific gravity of soil solids for a given soil sample was determined by density bottle method using kerosene. Following observations were recorded. Compute the specific gravity of soil solids at test temperature which was maintained at 27°. Also report the value at 4°C. Take specific gravity of kerosene at 27°C as 0.733.

AKTU 2018-19, Marks 07

Answer

Given : Specific gravity of kerosene at 27°C, $G_k = 0.733$.

Assumption : Following observations were recorded :

Mass of density bottle, $M_1 = 61.45 \text{ g}$

Mass of bottle + soil, $M_2 = 82.24 \text{ g}$

Mass of bottle + soil + kerosene, $M_3 = 261.12 \text{ g}$

Mass of bottle + kerosene, $M_4 = 246.49 \text{ g}$

To Find : Specific gravity of soil solids at 27°C and 4°C.

1. Mass of soil solids, $M_d = M_2 - M_1 = 82.24 - 61.45 = 20.79 \text{ g}$

2. We have, $M_4 - \frac{M_d}{G} + M_d = M_3$

$$G = \frac{M_d G_k}{M_d - (M_3 - M_4)}$$

$$= \frac{20.79 \times 0.733}{20.79 - (261.12 - 246.49)} = 2.474$$

$$G_{27^\circ\text{C}} = 2.474$$

3. If the value of G has to be reported at 4°C, we have

$$G_{4^\circ\text{C}} = G_{27^\circ\text{C}} \times \frac{\text{Specific gravity of water at } 27^\circ\text{C}}{\text{Specific gravity of water at } 4^\circ\text{C}}$$

$$= 2.474 \times \frac{0.9965}{1.000} = 2.465$$

Que 1.13. A soil sample assumed to consist of spherical grains all of same diameter will have maximum void ratio when the grains are arranged in a cubical array. Find the void ratio and dry unit weight. Take unit weight of grains as 20 kN/m³.

Answer

Given : Unit weight of grains, $\gamma = 20 \text{ kN/m}^3$.
To Find : Void ratio and dry unit weight.

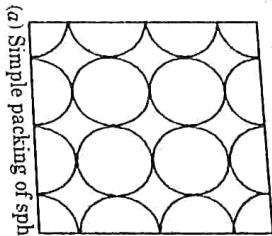

(a) Simple packing of spheres

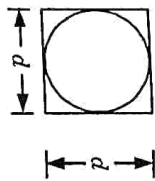

(b) Cubic element from simple packing

1. The volume of the cube space is d^3 , and the volume of the sphere is $\frac{\pi d^3}{6}$.

2. Hence, volume of voids = $\left[d^3 - \frac{\pi d^3}{6} \right]$

3. Void ratio = $\frac{\text{Volume of voids}}{\text{Volume of solid}} = \frac{\left[d^3 - \frac{\pi d^3}{6} \right]}{\left[\frac{\pi d^3}{6} \right]}$

$$= \frac{1 - \frac{\pi}{6}}{\frac{\pi}{6}} = 0.91$$

4. Thus, the void ratio in loosest state of packing (i.e., the maximum void ratio) = 0.91.

5. Assume, specific gravity of soil solids,

$$G = 2.65$$

$$\gamma_w = 9.81 \text{ kN/m}^3$$

Que 1.14. A natural soil deposit has bulk unit weight of 18.5 kN/m³ and water content of 5%. Calculate the amount of water required to be added to 5 m³ of soil to raise the water content to 14%. Assume the void ratio to remain constant. Also find degree of saturation, assume $G = 2.65$.

AKTU 2015-16, Marks 15

Answer

Given : Bulk unit weight, $\gamma = 18.5 \text{ kN/m}^3$, Water content, $w = 5\%$
Specific gravity, $G = 2.65$, Volume of soil = 5 m³, Final water content = 14%
To Find : Volume of water and Degree of saturation.

1. Weight of soil in 5 m³ volume = $18.5 \times 5 = 92.5 \text{ kN}$

2. Water content, $w = \frac{W_w}{W_s} = \frac{W_w}{W - W_w}$

$$0.05 = \frac{W_w}{92.5 - W_w}$$

$$W_w = 4.405 \text{ kN}$$

$$w = 14\%$$

3. When water content,

$$0.14 = \frac{W_w'}{W - W_w'}$$

4. Required weight of water = $W_w' - W_w$
= $11.36 - 4.405 = 6.955 \text{ kN}$

5. Volume of water, $V_w = \frac{6.955}{10} = 0.6955 \text{ m}^3$ [∵ $\gamma_w = 10 \text{ kN/m}^3$]

6. For Degree of Saturation, S :
Dry unit weight of soil,

$$\gamma_d = \frac{\gamma}{1 + w} = \frac{18.5}{1 + 0.05} = 17.62 \text{ kN/m}^3$$

7. Also, $\gamma_d = \frac{G\gamma_w}{1 + e}$

$$e = \frac{G\gamma_w}{\gamma_d} - 1 = \frac{2.65 \times 10}{17.62} - 1 = 0.504$$

8. We know that,

$$S = \frac{0.05 \times 2.65}{0.504} = 0.2629 = 26.3\%$$

Que 1.15. A soil specimen has a water content of 15% and a wet unit weight of 25 kN/m³. If the specific gravity of solids is 2.70, determine the dry unit weight, void ratio and the degree of saturation, take $\gamma_w = 10 \text{ kN/m}^3$.

AKTU 2016-17, Marks 10

Answer

Given : Water content, $w = 15\%$, Wet unit weight, $\gamma = 25 \text{ kN/m}^3$
 Specific gravity, $G = 2.7$, Unit weight of water, $\gamma_w = 10 \text{ kN/m}^3$
To Find : Dry unit weight, Void ratio and Degree of saturation.

- Dry unit weight, $\gamma_d = \frac{\gamma}{1+w} = \frac{25}{1+0.15} = 21.74 \text{ kN/m}^3$
- Now, $\gamma_d = \frac{G\gamma_w}{1+e}$
 $21.74 = \frac{2.7 \times 10}{1+e}$
 Void ratio, $e = 0.24$
- Degree of saturation, $S = \frac{wG}{e} = \frac{0.15 \times 2.7}{0.24} = 1.688$

Que 1.16. A soil sample of saturated soil has a water content of 35% and bulk unit weight of 25 kN/m³. Determine dry density, void ratio and specific gravity of solid particles. What would be the bulk unit weight of the same soil at the same void ratio but at a degree of saturation 60%, take $\gamma_w = 10 \text{ kN/m}^3$.

AKTU 2016-17, Marks 15

Answer

Given : Water content, $w = 35\%$, Saturated unit weight, $\gamma_{sat} = 25 \text{ kN/m}^3$, Degree of saturation, $S = 60\%$, Unit weight of water $\gamma_w = 10 \text{ kN/m}^3$
To Find : Dry density, void ratio, and specific gravity.

- Saturated unit weight, $\gamma_{sat} = \frac{G\gamma_w}{1+w} (1+w)$
 $25 = \frac{G \times 10(1+0.35)}{1+0.35 \times G}$
 $1 + 0.35G = 0.54G$
 Specific gravity, $G = 5.26$
- Taking, $S = 1$
 $Se = wG$

1-18A (CE-Sem-5)

Origin and Classification of Soil

Void ratio, $e = 0.35 \times 5.26 = 1.841$
 Dry unit weight, $\gamma_d = \frac{G\gamma_w}{1+e} = \frac{5.26 \times 10}{1+1.841} = 18.51 \text{ kN/m}^3$
 In the second case, $S = 60\%$

Bulk unit weight, $\gamma = \frac{(G + Se)\gamma_w}{1+e}$
 $\gamma = \frac{(5.26 + 0.60 \times 1.841) \times 10}{1+1.841} = 22.4 \text{ kN/m}^3$

Que 1.17. A mass of soil is coated with thin layer of wax, weight of soil and wax is 690.6 gm. Soil alone has 683 gm. When this sample is immersed in water it displaces 350 ml of water. Specific Gravity of solids is 2.73 and that of wax 0.89. Find void ratio and degree of saturation if water content in the soil is 17%.

AKTU 2017-18, Marks 10

Answer

Given : Mass of soil = 683 gm, Mass of soil with wax = 690.6 gm
 Volume of displace water = 350 ml, Specific gravity of soil = 2.73
 Specific gravity of wax = 0.89, Water content, $w = 17\%$
To Find : Void ratio and Degree of saturation.

- Mass of wax = 690.6 - 683 = 7.6 gm
- Volume of wax = $\frac{7.60}{0.89 \times 1.0} = 8.54 \text{ ml}$
- Volume of soil = 350 - 8.54 = 341.46 ml
- Bulk density, $\rho = \frac{683}{341.46} = 2 \text{ gm/ml}$
- Dry density, $\rho_d = \frac{\rho}{1+w} = \frac{2}{1+0.17} = 1.71 \text{ gm/ml}$
- We know that $\rho_d = \frac{G\rho_w}{1+e}$
 $1 + e = \frac{2.73 \times 1.0}{1.71} = 1.60$ ($\because \rho_w = 1 \text{ gm/ml}$)
 Void ratio, $e = 0.60$
- Degree of saturation, $S = \frac{wG}{e} = \frac{0.17 \times 2.73}{0.60} = 0.7735 = 77.35\%$

Que 1.18. Saturated clay has a water content of 39.3% and a mass specific gravity of 1.84. Determine the void ratio and the specific gravity of soil solids.

AKTU 2019-20, Marks 07

Answer

Given : Water content, $w = 39.3\%$, Mass specific gravity, $G_m = 1.84$
 To Find : Void ratio, Specific gravity of soil solids.

1. For saturated clay, mass specific gravity is given by,

$$G_m = \frac{\gamma_{sat}}{\gamma_w} = 1.84$$

2. Saturated unit weight of soil is given by,

$$\gamma_{sat} = \frac{\gamma_w (G + e)}{1 + e} \Rightarrow \frac{\gamma_{sat}}{\gamma_w} = \frac{G + e}{1 + e} \Rightarrow 1.84 = \frac{G + e}{1 + e}$$

...(1.18.1)

3. Void ratio is given by,

$$e = \frac{wG}{S} = \frac{0.393G}{1} = 0.393G \quad \dots(1.18.2)$$

4. From eq. (1.18.1) and eq. (1.18.2), we get

$$1.84 = \frac{G + 0.393G}{1 + 0.393G} \Rightarrow G = 2.74676$$

5. From eq. (1.18.2), we get

$$\text{Void ratio, } e = 0.393 \times 2.74676 = 1.08$$

PART-2

Clay Minerals, Soil Structure Index Properties, Sensitivity and Thixotropy, Particle Size Analysis, and Unified and Indian Standard Soil Classification System.

Questions-Answers

Long Answer Type and Medium Answer Type Questions

Que 1.19. What is meant by primary 'Valence bond' and 'Secondary Valence bond'?

AKTU 2017-18, Marks 02

Answer

Primary Valence Bond : Atoms bonding to atoms forming molecules are termed as primary valence bond. These are intra-molecular bond. Example : Ionic bonds, covalent bonds etc.

Secondary Valence Bond : When atoms in one molecule bond to atoms of another molecule, secondary valence bonds are formed. These are intermolecular bond.

Example : Vander Waals forces, Hydrogen bond etc.

Que 1.20. What is a 'silica tetrahedron' and an 'aluminium octahedron'? How are silica sheet and alumina sheet formed? Show their schematic representation.

Answer

All the clay minerals are found in two fundamental building blocks :

A. Tetrahedron unit, and B. Octahedron unit :

A. Silica Tetrahedron :

Silica tetrahedron is a fundamental structural unit consists of a silicon cation surrounded by four oxygen anions, giving it four negative charges. It is found in all silicate minerals.

Fig. 1.20.1(a) shows a single silica tetrahedron.

Fig. 1.20.1(b) illustrates how the oxygen atoms at the base of each tetrahedron combine to form a sheet structure with all the tips of the bases lying in a common plane.

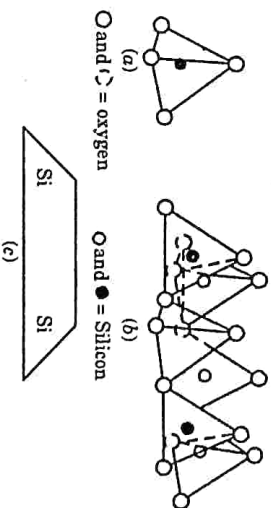

Fig. 1.20.1. (a) Single silica tetrahedron. (b) Isometric view of the tetrahedral or silica sheet. (c) Symbolic representation of the silica sheet.

- The sharing of charges leaves three negative charges at the base per tetrahedral unit.
 - This, along with the two negative charges at the apex, makes total of five negative charges to four positive charges of the silicon ion. Thus, there is a net (-1) per unit.
 - A symbolic representation of silica sheet is shown in Fig. 1.20.1(c).
- B. Aluminium Octahedral :**
- An aluminium ion surrounded by six oxygen atoms or hydroxyl group gives an eight sided building block termed octahedron.

2. An octahedral unit has six hydroxyl ions at the tips of an octahedron as shown in Fig. 1.20.1(a) and Fig. 1.20.1(b).

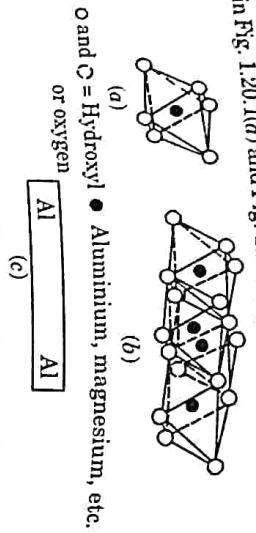

Fig. 1.20.2. (a) Single aluminium (or magnesium) octahedron. (b) Isometric view of the octahedral sheet. (c) Symbolic representation of the octahedral or alumina (or magnesia) sheet.

- It shows that the octahedral units are bound together in a sheet structure and Fig. 1.20.2(c) is showing the symbolic representation of octahedral sheet.
- The net charge of an octahedral unit with aluminium ion is (+3).
- Charge at the centre is (+1).

Que 1.21. Illustrate by schematic diagrams, how the clay minerals kaolinite, illite and montmorillonite are formed ?

AKTU 2017-18, Marks 05

OR
Define clay minerals. Also discuss montmorillonite with neat sketches.

AKTU 2018-19, Marks 07

Answer

Clay Minerals : The clay materials are basically composed of tiny crystalline substance of one or more members of a small group of minerals commonly known as clay minerals. Most common clay minerals are given below :

A. Kaolinite :

- Kaolinite is the most common minerals of the kaolinite group of clay minerals.
- Its basic structural unit consists of gibbsite sheet (G) with aluminium atoms at the centre.
- It is joined to silica sheet (S) through the unbalanced oxygen atoms at the apexes of the silica sheet.
- The total thickness of the basic structural units is about 7 Å.
- The basic structural unit of kaolinite mineral is symbolized as shown in Fig. 1.21.1(a).

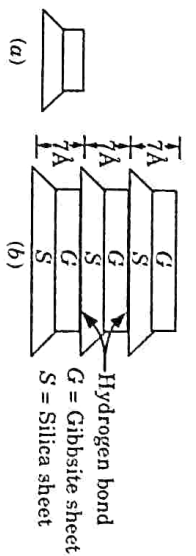

Fig. 1.21.1. Structure of kaolinite mineral.

- The basic structural units of kaolinite mineral are joined together by hydrogen bond. It develops between the oxygen atoms of silica sheet and the hydroxyls of gibbsite sheet.
- Since the hydrogen bond is fairly strong, it is extremely difficult to separate the layers, and hence, kaolinite mineral is relatively stable. Moreover, water cannot penetrate through the layers of the structural units of kaolinite minerals.
- Kaolinite shows relatively little swell on wetting.
- China clay is almost pure kaolinite.

B. Montmorillonite :

- Montmorillonite is the most common mineral of the montmorillonite group of clay minerals.
- Its basic structural unit consists of gibbsite sheet (G) sandwiched between two silica sheets (S).
- The gibbsite sheet may include atoms of aluminium, iron or magnesium, or a combination of these.
- The total thickness of basic structural unit of montmorillonite is about 10 Å.
- The basic structural units of montmorillonite mineral are joined together by a link between oxygen ions of the two silica sheets.
- The link is due to natural attraction for the cations in the intervening space and due to Vander Waal forces.
- Water may enter between the silica sheets causing the mineral to swell. For this reason, montmorillonite tends to expand on wetting.

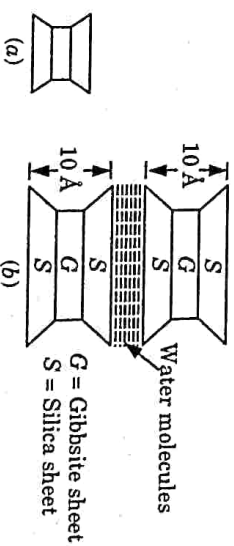

Fig. 1.21.2. Structure of montmorillonite mineral.

- C. Illite :
- Illite mineral is the most common mineral of the illite group of clay minerals.

2. Its basic structural unit is similar to that of montmorillonite mineral except that there is always substantial (20 % F) substitution of silicon atoms by aluminium atoms in silica sheet.
3. Also, the link between the different basic structural units is through non-exchangeable potassium (K^+) ions.
4. The basic structural unit of illite is symbolically represented as shown in Fig. 1.21.3(a).

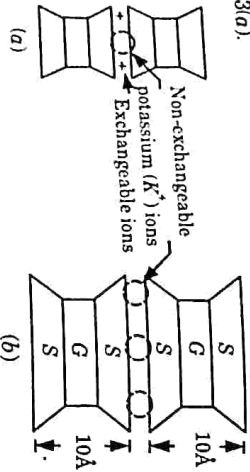

Fig. 1.21.3. Structure of illite mineral.

5. The swelling of illite is more than that of kaolinite, but less than that of montmorillonite.
6. Thus, the properties of illite are somewhat intermediate between those of kaolinite and montmorillonite.

Que 1.22. Write short note on :

1. Single-grained structure.
2. Honey comb-structure.
3. Flocculated structure.

Answer

1. Single-Grained Structure :

- i. Cohesionless soils, such as gravel and sand, are composed of bulky grains in which the gravitational forces are more predominant than surface forces.
- ii. When deposition of these soils occurs, the particles settle under gravitational forces and take an equilibrium position as shown in Fig. 1.22.1(a). Each particle is in contact with those surrounding it. The soil structure so formed is known as single-grained structure.



(a) Single-grained structure

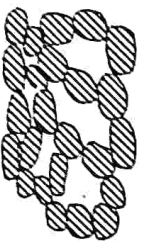

(b) Honey-comb structure

Fig. 1.22.1.

2. **Honey-Comb Structure :**
 - i. It is possible for fine sands or silts to get deposited such that the particles when settling develop a particle-to-particle contact that bridges over large voids in the soil mass [Fig. 1.22.1(b)]. The particles wedge between one another into a stable condition and form a skeleton like an arch to carry the weight of the overlying material. The structure so formed is known as honey-comb structure.
 - ii. The honey-comb structure usually develops when the particle size is between 0.002 mm and 0.02 mm.
 - iii. Honey-comb structure occurs in soils having small granular particles which have cohesion because of their fineness. Soils in honey-comb structure are loose.
3. **Flocculated Structure :**
 - i. Flocculated structure occurs in clays. The clay particles have large surface area and, therefore, the electrical forces are important in such soils.
 - ii. The clay particles have a negative charge on the surface and a positive charge on the edges.
 - iii. Interparticle contact develops between the positively charged edges and the negatively charged faces. This results in a flocculated structure as shown in Fig. 1.22.2.



Flocculated structure

Fig. 1.22.2. Flocculated structure of clays.

Que 1.23. What is particle size analysis ? Also describe the sieve analysis method.

Answer

Particle-Size Analysis :

1. Particle size analysis is an analytical technique by which the distribution of sizes in a sample of soil is measured and reported.
2. Percentage of different size of particles present in a given dry sample of soil is computed by particle size analysis or mechanical analysis. It is generally being carried out in two stages :
 - i. Sieve analysis.
 - ii. Sedimentation analysis / wet mechanical analysis.
3. **A. Sieve Analysis :** Sieve analysis is being carried out for coarse grained particle having size greater than 0.075 mm (75 μ m).
 2. Sieve analysis is further of two types :
 - i. Coarse sieving (4.75 < d < 80 mm).

- ii. Fine sieving ($0.075 < d < 4.75 \text{ mm}$).

- Sieves are designed by the size of aperture in mm as per IS : 460-1962.
- Wet sieving is carried out for separating fine grains from coarse grains by washing the soil specimen on a 75 micron sieve mesh.
- Dry sieve analysis is carried out on particles coarser than 75 micron. Samples (with fines removed) are dried and shaken through a set of sieves of descending size. The weight retained in each sieve is measured. The cumulative percentage quantities finer than the sieve sizes (passing each given sieve size) are then determined.
- The resulting data is presented as a distribution curve with grain size along X-axis (log scale) and percentage passing along Y-axis (arithmetic scale).

Que 1.24. Write short note on sedimentation analysis. What are the limitations of Stoke's law in sedimentation analysis ?

OR

What are the limitations in the use of Stoke's law in sedimentation analysis ?

AKTU 2015-16, Marks 10

Answer

A. Sedimentation Analysis :

- It is being carried out for the particles having size less than 0.075 mm (fine grain particles).
- Particles having size less than 0.0002 mm cannot be analyzed even by sedimentation. These particles can be analyzed by electron microscope or by X-ray diffraction.
- This analysis is based on Stoke's law. According to Stoke's law, velocity of particle during settlement, that is assumed to be spherical, is dependent upon shape, size and mass of the particle and keeping all the other factors constant.

$$v = \frac{(G-1) r_p D^2}{18\mu}$$

where, G = Specific gravity,

μ = Kinematic viscosity,

B. Limitations : Following are the limitations of Stoke's law :

- Stoke's law is applicable only when the liquid is infinite. The presence of walls of the jar affects the results to some extent.
- In Stoke's law, it has been assumed that only one sphere settles, and there is no interference from other spheres. In the sedimentation analysis, as many particles settle simultaneously, there is some interference.

- The sedimentation analysis cannot be used for particles larger than 0.2 mm as turbulent conditions develop and Stoke's law is not applicable.
- The sedimentation method is not applicable for particles smaller than 0.2 μ because Brownian movement takes place and the particles do not settle as per Stoke's law.

Que 1.25. What is hydrometer ? Explain all the corrections which are used in hydrometer analysis.

Answer

A. Hydrometer : A hydrometer is an instrument used for determining the specific gravity of liquids. As the specific gravity of the soil suspension depends upon the particle size, a hydrometer can be used for the particle size analysis.

B. Corrections in Hydrometer Analysis : Following are the corrections applied in observed hydrometer analysis :

- Meniscus Correction :**
The hydrometer reading of lower meniscus is to be taken. But since the soil suspension is opaque the reading of upper meniscus is taken instead of lower meniscus. Because of this an error is introduced.
- A correction due to meniscus ($+ C_m$) is then applied to the hydrometer reading.

2. Temperature Correction :

- Hydrometers are calibrated at a temperature of 27°C.

- In case the temperature of the suspension is different from 27°C, a correction due to temperature ($+ C_t$) is to be applied to the observed hydrometer readings.

- If the test temperature is above the standard, the correction is added and, if below, it is subtracted.

3. Dispersion Agent Correction :

- The correction due to rise in specific gravity of the suspension on account of the addition of the deflocculating/dispersing agent is called the dispersing agent correction (C_d). C_d is always negative.

- The corrected hydrometer reading R_c is given by,

$$R_c = R_H + C_m + C_t - C_d$$

where, R_H = Observed hydrometer reading.

R_c correct hydrometer reading used in the calibration graph to obtain the effective depth H_e .

Que 1.26. What is the use of particle size distribution curve ? With the help of particle size distribution curve.

AKTU 2018-19, Marks 07

Answer

A. Particle Size Distribution Curve :

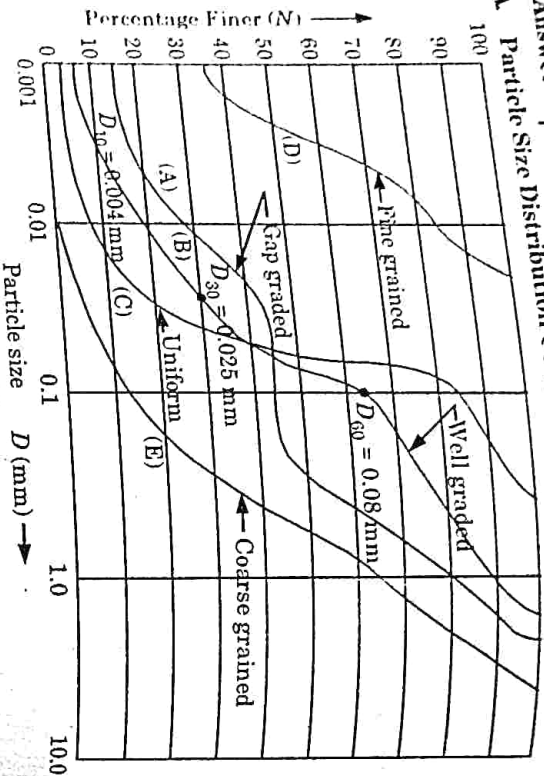

Fig. 1.26.1.

B. Uses : Following are the uses of particle size distribution curve :

1. It is used in the classification of coarse-grained soils.
2. The particle size is used to know the susceptibility of a soil to frost action.
3. It is required for the design of drainage filters.
4. It provides an index to the shear strength of the soil. Generally, a well-graded, compacted sand has high shear strength.
5. The compressibility of a soil can also be judged from its curve. A uniform soil is more compressible than a well-graded soil.
6. It is useful in soil stabilization and for the design of pavements.
7. It may indicate the mode of deposition of a soil. For example, a gap-graded soil indicates deposition by two different agencies.

Que 1.27. Data from the grain size analysis for a soil is tabulated below.

Diameter in mm	2.0	1.4	0.600	0.425	0.250	0.150	0.075
Percentage Finer	100	94	68	54	30	16	4

- A. Plot the grain size distribution curve for this soil.
- B. Classify the soil.
- C. Calculate C_u and C_c value for the soil.

Answer

A. Grain size Distribution Curve : It is shown in Fig. 1.27.1.

B. Classification of Soil :

1. It is a coarse grained (sand) soil, since only 4% passes through 75 μ m.
2. As a greater percentage of coarse fraction passes through 2 mm sieve, soil is sand.

C. Calculation for C_u and C_c :

From the grain size curve (Fig. 1.28.1),

$D_{10} = 0.1, D_{30} = 0.25, \text{ and } D_{60} = 0.5$

2. Coefficient of uniformity,

$$C_u = \frac{D_{60}}{D_{10}} = \frac{0.5}{0.1} = 5$$

3. Coefficient of curvature,

$$C_c = \frac{D_{30}^2}{D_{60} \times D_{10}} = \frac{0.25^2}{0.5 \times 0.1} = 1.25$$

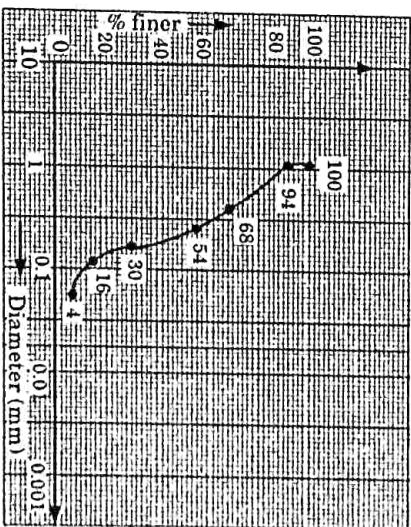

Fig. 1.27.1. Grain size distribution curve.

Que 1.28. A soil sample has 97% of the particles (by weight) finer than 1 mm, 58% finer than 0.1 mm, 25% finer than 0.01 mm and 12% finer than 0.001 mm. Draw the grain size distribution curve and determine the following :

Percentages of gravel, coarse sand, medium sand, fine sand and silt as per IS soil classification system. Also determine C_u and C_c .

Answer					
Given :	Diameter of Grain (mm)	1.00	0.10	0.01	0.001
	Percentage Finer	97	58	25	12

To Find : Grain size distribution curve, % of gravel, coarse sand, medium sand, fine sand and silt and C_u and C_c .

1. By interpolation,

Table 1.28.1.

Diameter of Grain (mm)	1.00	0.425	0.1	0.075	0.01	0.001
Percentage Finer	97	72.083	58	34.416	25	12

- Percentage of gravel (> 4.75 mm) = 0%
- Percentage of coarse sand (4.75 mm - 2.0 mm) = 97% - 72.083% = 24.917%
- Percentage of fine sand (0.425 mm - 0.075 mm) = 72.083% - 34.416% = 37.667%
- Percentage of silt (< 0.075 mm) = 34.416%
- Calculate the value of D_{10} , D_{30} and D_{60} by interpolation from table. 1.28.1
- Effective size of soil, $D_{10} = 0.00099$ mm
 $D_{30} = 0.145$ mm
 $D_{60} = 0.0445$ mm
- Uniformity coefficient,
 $C_u = \frac{D_{60}}{D_{10}} = \frac{0.146}{0.00099} = 147.475$
- Coefficient of curvature,
 $C_c = \frac{(D_{30})^2}{D_{60} \times D_{10}} = \frac{(0.0445)^2}{0.146 \times 0.00099} = 13.7$

Que 1.29. Write short note on thixotropy of clay.

Answer

- When naturally formed clays are remoulded, their original clay structure is destroyed and they lose their strength.
- The loss of strength of a soil due to remoulding is partly due to change in the soil structure and partly due to disturbance caused to water molecules in the absorbed layer.
- Some of these changes are reversible.
- If a remoulded soil is allowed to stand, without loss of water, it may regain some of its lost strength.

5. In soil engineering, the gain in strength of the soil with passage of time after it has been remoulded is called thixotropy.

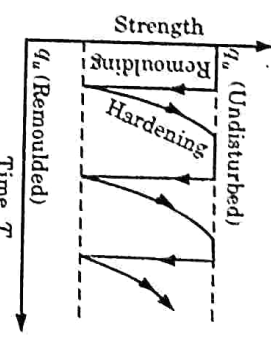

Fig. 1.29.1.

6. It is mainly due to a gradual reorientation of molecules of water in the adsorbed water layer and due to reestablishment of chemical equilibrium.

Que 1.30. What is plasticity index and how will you classify the soil with the help of plasticity chart? Also write the equation of the 'A Line' in this plasticity chart.

Answer

- Plasticity Index :** It is the range of water content over which the soil remains in the plastic state. It is equal to the difference between the liquid limit and plastic limit.
Thus, $I_p = W_L - W_P$
- Classification of Fine Grained Soils :**
The plasticity index and the liquid limit can be used to classify fine-grained soil via plasticity chart shown in Fig. 1.30.1.

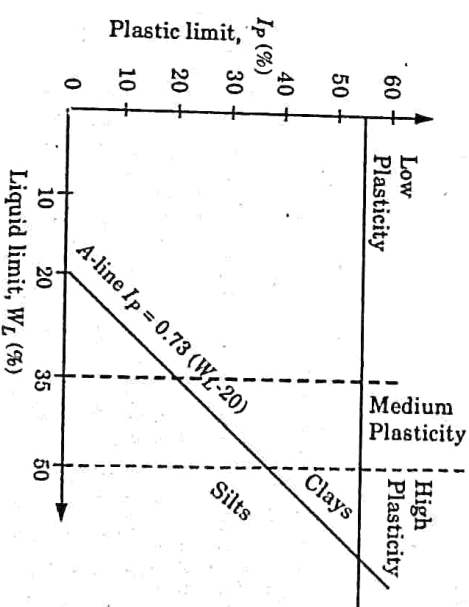

Fig. 1.30.1.

- The line shown in Fig. 1.30.1 separates silts from clays.
- In the plasticity chart, the liquid limit (LL) of a given soil determines its plasticity. Soils are classified on the bases of LL as follows:
 - $LL < 35 \Rightarrow$ Low-plasticity clays (or low-compressibility).
 - $35 < LL \leq 50 \Rightarrow$ Medium-plasticity clays (or medium-compressibility silts).
 - $LL > 50 \Rightarrow$ High-plasticity clays for high-compressibility silts.
- To determine the state of a natural soil with an in-situ moisture content w , we can use the liquidity index (LI), defined as

$$LI = \frac{w - PL}{LL - PL}$$

- For heavily overconsolidated clays, $w < PL$ and therefore $LI < 0$, and the soil is classified as nonplastic (i.e., brittle); if $0 \leq LI \leq 1$ (i.e., $PL < w < LL$), the soil is in its plastic state; and if $LI > 1$ (i.e., $w > LL$), the soil is in its liquid state.

Que 1.31. The liquid limit of clay is 64% and its plastic limit is 34%. Its natural water is 48%. What is the liquidity index of the soil? How do you classify the soil as per the IS classification?

AKTU 2019-20, Marks 07

Answer

Given : Liquid limit, $w_L = 64\%$, Plastic limit, $w_p = 34\%$, Natural water content, $w = 48\%$

To Find : Liquidity index and Classify the soil.

- Plasticity index, $I_p = w_L - w_p = 64\% - 34\% = 30\%$
- Liquidity index is given by,

$$I_L = \frac{w - w_p}{I_p} \times 100 = \frac{48 - 34}{30} \times 100 = 46.67\%$$

- On the basis of liquid limit (64%). A-line is given by, $I_p = 0.73(w_L - 20) = 0.73(64 - 20) = 32.12\% > 30\%$. Hence, Atterberg limit plot below A-line. Therefore soil is organic clay of medium to high plasticity.

Que 1.32. The plastic limit of soils is 24% and its plasticity index is 8%.

When the soil is dried from its state of plastic limit, the volume change is 26% of its volume of plastic limit. The corresponding volume change from liquid limit to dry state is 35% of its volume of liquid limit. Determine the shrinkage limit and the shrinkage ratio.

AKTU 2018-19, Marks 07

Answer

Given : Plastic limit, $w_p = 24\%$, Plasticity index, $I_p = 8\%$
Volume change at liquid limit = 35%
Volume change at plastic limit = 26%

To Find : Shrinkage limit and Shrinkage ratio.

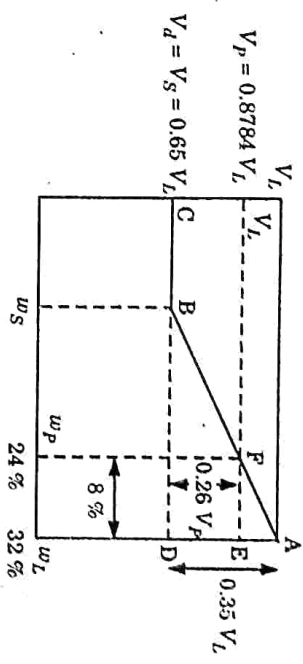

Fig. 1.32.1.

- Liquid limit, $w_L = 24\% + 8\% = 32\%$
- Dry volume, $V_d = V_s = V_L - 0.35 V_L = 0.65 V_L$
 $V_d = V_p - 0.26 V_p = 0.74 V_p$
- From eq. (1.19.1) and eq. (1.19.2), we get

$$V_p = \frac{0.65}{0.74} V_L = 0.8784 V_L$$

- ΔABD and ΔAFE are similar,

$$\frac{BD}{AD} = \frac{FE}{AE} = \frac{0.32 - 0.24}{0.1216 V_L}$$

$$BD = \frac{0.08}{0.1216 V_L} \times 0.35 V_L = 0.2302 = 23.02\%$$

- Shrinkage limit, $w_s = w_L - BD = 32\% - 23.02\% = 8.98\%$

- Shrinkage ratio, $SR = \frac{(V_L - V_d)/V_d}{w_L - w_s} \times 100$

$$= \frac{0.35 V_L / 0.65 V_L}{32 - 8.98} \times 100$$

$$SR = 2.339$$

Que 1.33. If the material of the base of the liquid limit apparatus

on which the bowl containing soil drops is made of sponge, will the measured value of liquid limit of the soil be lower or higher than that measured using the standard apparatus which has a base made of hard rubber? Discuss the result.

Answer

The liquid limit is less in sponge as compare to hard rubber. Following reasons are responsible for less liquid limit :

1. When hard rubber is used, it can bear the shocks of the cup during test. It will behave like a hard surface. Due to this, the soil displaces from its place. This will show that how much liquid is available in that sample, it will show higher liquid limit than spongy material surface as shocks energy is absorbed by sponge and soil will not move. Hence, it possesses low liquid limit.
2. From classification curve of Atterberg, we can say that if the water content is less in soil, it will behave like a plastic material as in case of spongy surface in which the soil does not move, will behave as plastic or solid soil or possesses less liquid limit.

Que 1.34. Give the grain size range of different soil types according to IS specification.

Answer

Grain Size Range :
As shown in Fig. 1.34.1, in this classification the soils with particle size less than 0.002 mm are classified as clay size (or clays).

Clay	Silt	Fine	Medium	Coarse	Fine	Coarse	Cobble	Boulder
		0.075	0.425	2.00				
		0.002						

IS Classification (IS : 1498-1970)

Fig. 1.34.1. Particle size (or Grain size) classification.

1. The soils with particle size between 0.002 mm and 0.075 mm are classified as silt size (or silts).
2. The soils with particle size between 0.075 mm and 4.75 mm are classified as sand size (or sand) and these are further subdivided into three categories as fine, medium and coarse sands as shown in Fig. 1.34.1.
3. The soils with particle size between 4.75 mm and 80 mm classified as gravels which are further subdivided into two categories as fine and coarse gravels as shown in Fig. 1.34.1.
4. The soils with particle size between 80 mm and 300 mm are classified as cobbles and those with particle size larger than 300 mm are classified as boulders.

VERY IMPORTANT QUESTIONS

Following questions are very important. These questions may be asked in your SESSIONALS as well as UNIVERSITY EXAMINATION.

Q. 1. What do you understand by residual soil and transported soil ?

Ans: Refer Q. 1.2, Unit-1.

Q. 2. Define the basic terms which are related to soil system.

Ans: Refer Q. 1.7, Unit-1.

Q. 3. An oven dry soil sample of volume 250 cc weight 430 g. If the specific gravity of solids is 2.70, what is the water content when the soil becomes fully saturated without any change in its volume ? What will be the water content which will fully saturate the sample and also cause an increase in volume equal to 10 % of the original dry volume ?

Ans: Refer Q. 1.10, Unit-1.

Q. 4. The specific gravity of soil solids for a given soil sample was determined by density bottle method using kerosene. Following observations were recorded. Compute the specific gravity of soil solids at test temperature which was maintained at 27°. Also report the value at 4°C. Take specific gravity of kerosene at 27°C as 0.733.

Ans: Refer Q. 1.12, Unit-1.

Q. 5. What is a 'silica tetrahedron' and an 'aluminium octahedron'? How are silica sheet and alumina sheet formed ? Show their schematic representation.

Ans: Refer Q. 1.21, Unit-1.

Q. 6. Illustrate by schematic diagrams, how the clay minerals kaolinite, illite and montmorillonite are formed ?

Ans: Refer Q. 1.22, Unit-1.

Q. 7. What is the use of particle size distribution curve ? With the help of particle size distribution curve.

Ans: Refer Q. 1.27, Unit-1.

Q. 8. What is plasticity index and how will you classify, the soil with the help of plasticity chart ? Also write the equation of the 'A Line' in this plasticity chart.

Ans: Refer Q. 1.31, Unit-1.

Q. 9. The liquid limit of clay is 64 % and its plastic limit is 34 %. Its natural water is 48 %. What is the liquidity index of the soil ? How do you classify the soil as per the IS classification ?

Ans: Refer Q. 1.32, Unit-1.



2

UNIT

Soil Hydraulics

CONTENTS

Part-1 : Stress Condition in soil-Total, Effective and Neutral, Stresses and Relationships, Darcy's Law, Permeability-Hydraulic Conductivity, Equivalent Hydraulic Conductivity in Stratified Soil 2-2A to 2-30A
Part-2 : Seepage, Flowmets, Seepage Calculation from a Flowmets, Flowmets in Anisotropic Soils, Seepage Through Earth Dam, Capillarity, Critical Hydraulic Gradient and Quick Sand Condition, Uplift Pressure, Piping 2-20A to 2-31A

2-2A (CE-Sem-5)

Soil Hydraulics

PART-1

Stress Condition in soil-Total, Effective and Neutral, Stresses and Relationships, Permeability-Darcy's Law, Hydraulic Conductivity, Equivalent Hydraulic Conductivity in Stratified Soil.

Questions-Answers

Long Answer Type and Medium Answer Type Questions

Que 2.1. Define the term total stress, pore water stress and effective stress for given soil.

Answer

1. Total Stress :

- i. When a load is applied to soil, it is carried by the solid grains and the water in the pores.
- ii. The total vertical stress acting at a point below the ground surface is due to the weight of everything that lies above, including soil, water and surface loading.

Vertical total stress at height h , $\sigma = \gamma_{sat} h$
 Total stress thus increases with height and with unit weight.

2. Pore Water Pressure :

- i. Pore water pressure (u) is the pressure due to pore water filling the voids of the soil. Thus

$$u = \gamma_w h$$

- ii. Pore water pressure is also known as neutral pressure or neutral stress, because it cannot resist shear stresses.

3. Effective Stress :

- i. The effective stress ($\bar{\sigma}$) at a point in the soil mass is equal to the total stress minus the pore water pressure. Thus,

$$\bar{\sigma} = \sigma - u$$

- ii. For saturated soils, it is obtained as :

$$\bar{\sigma} = \gamma_{sat} h - \gamma_w h = (\gamma_{sat} - \gamma_w) h = \gamma' h$$

where, γ' = Submerged unit weight.

Que 2.2. In a cohesionless soil deposit, the water table is at the ground surface. If the saturated unit weight is 18 kN/m^3 , compute the total stress, pore pressure and effective stress at a depth of 5 m, for the upward flow under a gradient of 0.5.

Answer

Given : Saturated unit weight, $\gamma_{sat} = 18 \text{ kN/m}^3$,
 Depth of soil, $H = 5 \text{ m}$, Gradient, $i = 0.5$
 To Find : Total stress, Pore pressure and effective stress.

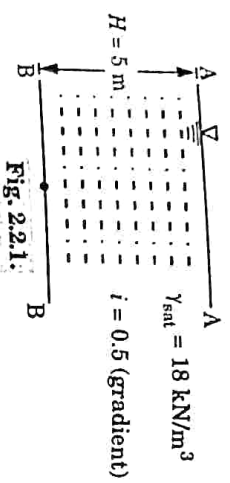

Fig. 2.2.1

- Total stress at level B—B (below the 5 m depth)
 $\sigma = \gamma_{sat} \times H = 18 \times 5 = 90 \text{ kN/m}^2$
- Total head = $(H + h)$
 Where h is pressure head loss due to upward flow water.
- Gradient, $i = \frac{h}{H}$
 $h = i \times H = 0.5 \times 5 = 2.5$
- Pore pressure at level B, $u = (H + h) \gamma_w = (5 + 2.5) \times 10 = 75 \text{ kN/m}^2$
- Effective stress = Total stress - Pore pressure = $\sigma - u$
 $\bar{\sigma} = 90 - 75 = 15 \text{ kN/m}^2$
- Stress Distribution :

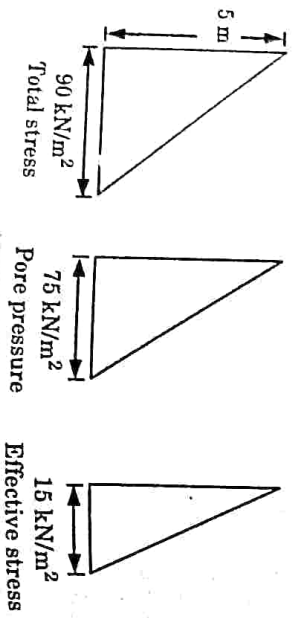

Fig. 2.2.2

Que 2.3. The difference in values of capillary rise for fine sand and silt was found to be 4.5 m. If the capillary rise in fine sand is 0.5 m. Compute the difference in size of voids of the two soils.

Answer

Given : Difference of capillary rise = 4.5 m,
 Capillary rise in fine sand = 0.5
 To Find : Difference in size of voids.

- Let capillary rise for fine sand = h_{r1}
 Capillary rise for silt = h_{r2}
- According to question, $h_{r1} - h_{r2} = 4.5 \times 10^2 \text{ cm}$
 To Find : Difference in size of voids.
- We know,
 $h_c = \frac{0.30}{d}$
- $h_{r1} = 0.5 \text{ m} = 50 \text{ cm}$
 $h_{r2} = 450 - 50 = 400 \text{ cm}$
 $h_{r1} = \frac{0.30}{d_1}$
 $d_1 = \frac{0.30}{50} = 6 \times 10^{-3} \text{ cm}$
- $h_{r2} = \frac{0.30}{d_2}$
 $d_2 = \frac{0.30}{400} = 7.5 \times 10^{-4} \text{ cm}$
- Difference in size of void,
 $d_1 - d_2 = 6 \times 10^{-3} - 7.5 \times 10^{-4} = 5.25 \times 10^{-3} \text{ cm}$

Que 2.4. A soil profile consists of a surface layer of sand 3.5 m thick ($\rho = 1.65 \text{ Mg/m}^3$), an intermediate layer of clay 3 m thick ($\rho = 1.95 \text{ Mg/m}^3$) and the bottom layer of gravel 3.5 m thick ($\rho = 1.925 \text{ Mg/m}^3$). The water table is at the upper surface of the clay layer. Determine the effective pressure at various levels immediately after placement of a surcharge load of 58.86 kN/m^2 to the ground surface.

Answer

Given : For sand layer : $h = 3.5 \text{ m}$, $\rho = 1.65 \text{ Mg/m}^3$
 For clay layer : $h = 3 \text{ m}$, $\rho = 1.95 \text{ Mg/m}^3$
 For gravel layer : $h = 3.5 \text{ m}$, $\rho = 1.925 \text{ Mg/m}^3$
 Surcharge = 58.86 kN/m^2
 To Find : Stresses at various levels

- At Section A-A : $\sigma = 58.86 \text{ kN/m}^2$, $u = 0$, $\bar{\sigma} = 58.86 \text{ kN/m}^2$
- At Section B-B : $\sigma = 58.86 + 3.5(1.65 \times 9.81) = 115.51 \text{ kN/m}^2$

$u = 0, \bar{\sigma} = 115.51 \text{ kN/m}^2$

58.86 kN/m^2

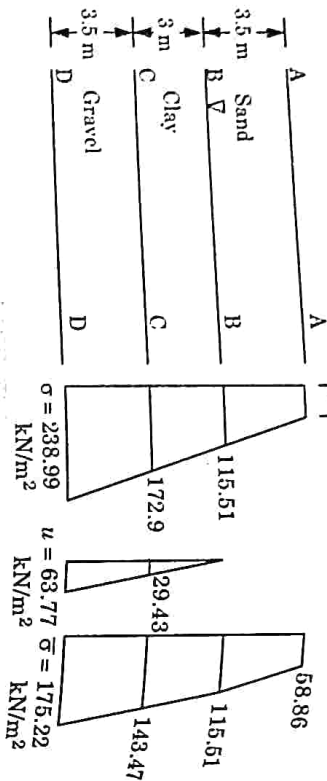

Fig. 2.4.1.

3. At Section C-C : $\sigma = 115.51 + 3 \times (1.95 \times 9.81) = 172.90 \text{ kN/m}^2$
 $u = 3 \times 9.81 = 29.43 \text{ kN/m}^2$
 $\bar{\sigma} = 172.90 - 29.43 = 143.47 \text{ kN/m}^2$
4. At Section D-D : $\sigma = 172.90 + 3.5(1.925 \times 9.81) = 238.99 \text{ kN/m}^2$
 $u = 6.5 \times 9.81 = 63.77 \text{ kN/m}^2$
 $\bar{\sigma} = 238.99 - 63.77 = 175.22 \text{ kN/m}^2$

Que 2.5. A granular soil deposit has 10 m depth over an impermeable layer. The ground water table is at 5 m depth below ground surface. The soil is moist up to 2 m from water table with degree of saturation of 50%. Plot the variation of total stress, pore water pressure and effective stress. Take $e = 0.6$ and $G = 2.67$.

Answer

Given : Depth of soil deposit = 10 m
 Specific gravity, $G = 2.67$, Degree of saturation, $S = 0.5$
 Void ratio, $e = 0.6$

To Find : Plot variation of σ , u and $\bar{\sigma}$

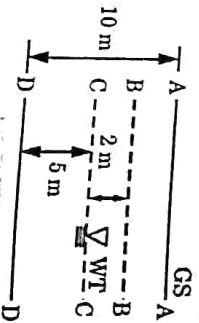

Fig. 2.5.1.

2-6 A (CE-Sem-5)

Soil Hydraulics

1. Bulk unit weight,

$$\gamma_{bc} = \left(\frac{G + Se}{1 + e} \right) \gamma_w$$

$\gamma_w = 10 \text{ kN/m}^3 = \text{Unit weight of water}$

$$\gamma_{bc} = \left(\frac{2.67 + 0.5 \times 0.6}{1 + 0.6} \right) \times 10 = 18.56 \text{ kN/m}^3$$

$$\gamma_{ast} = \left(\frac{G + e}{1 + e} \right) \gamma_w = \left(\frac{2.67 + 0.6}{1 + 0.6} \right) \times 10 = 20.44 \text{ kN/m}^3$$

$$\gamma_{AB} = \frac{G\gamma_w}{1 + e} = \frac{2.67 \times 10}{1 + 0.6} = 16.69 \text{ kN/m}^3$$

4. At Level A-A :

$$\sigma = u = \bar{\sigma} = 0$$

5. At Level B-B (Upper Side) :

$$\sigma = \gamma_h = 16.69 \times 3 = 50.07 \text{ kN/m}^2$$

$$u = 0$$

$$\bar{\sigma} = 50.07 - 0 = 50.07 \text{ kN/m}^2$$

6. At Level B-B (Bottom Side) :

$$\sigma = 16.69 \times 3 = 50.07 \text{ kN/m}^2$$

$$u = -2 \times 9.81 = -19.62 \text{ kN/m}^2$$

$$\bar{\sigma} = 50.07 + 19.62 = 69.69 \text{ kN/m}^2$$

7. At Level C-C :

$$\sigma = 16.69 \times 3 + 2 \times 18.56 = 87.19 \text{ kN/m}^2$$

$$u = 0$$

$$\bar{\sigma} = 87.19 - 0 = 87.19 \text{ kN/m}^2$$

8. At Level D-D :

$$\sigma = 3 \times 16.69 + 2 \times 18.56 + 5 \times 20.44$$

$$= 189.39 \text{ kN/m}^2$$

$$u = 5 \times 9.81 = 49.05 \text{ kN/m}^2$$

$$\bar{\sigma} = 189.39 - 49.05 = 140.34 \text{ kN/m}^2$$

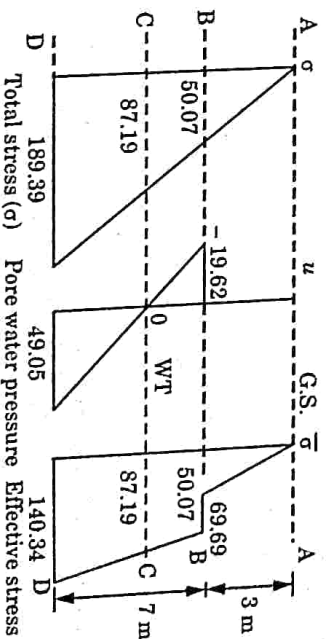

Fig. 2.5.2. Variation of σ , u and $\bar{\sigma}$ (All values are in kN/m^2).

Que 2.6. A granular soil deposit is 7 m deep over an impermeable layer. The ground water table is 4 m below the ground surface. The deposit has a zone of capillary rise of 1.2 m with a saturation of 50%. Plot the variation of total stress, pore water pressure and effective stress with the depth of deposit, $e = 0.6$ and $G = 2.65$.

AKTU 2019-20, Marks 07

Answer

Given : Depth of soil deposit = 7 m, Depth of water table = 4 m
 Specific gravity, $G = 2.65$, Degree of saturation, $S = 50\%$
 Void ratio, $e = 0.6$, Capillary rise = 1.2 m
 To Find : Plot the variation of σ , u and $\bar{\sigma}$ with the depth of deposit.

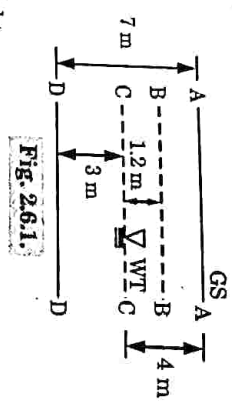

Fig. 2.6.1.

1. Bulk unit weight,

$$\gamma_{BC} = \left(\frac{G + Se}{1 + e} \right) \gamma_w$$

$$\gamma_w = 10 \text{ kN/m}^3 = \text{Unit weight of water}$$

$$\gamma_{BC} = \left(\frac{2.65 + 0.5 \times 0.6}{1 + 0.6} \right) \times 10 = 18.44 \text{ kN/m}^3$$

2. Saturate unit weight, $\gamma_{sat} = \left(\frac{G + e}{1 + e} \right) \gamma_w = \left(\frac{2.65 + 0.6}{1 + 0.6} \right) \times 10 = 20.3125 \text{ kN/m}^3$

3. Dry unit weight, $\gamma_{AB} = \frac{G \gamma_w}{1 + e} = \frac{2.65 \times 10}{1 + 0.6} = 16.5625 \text{ kN/m}^3$

4. At Level A-A :

$$\sigma = u = \bar{\sigma} = 0$$

5. At Level B-B (Upper Side):

$$\sigma = \gamma_h = 16.5625 \times (4 - 1.2) = 46.375 \text{ kN/m}^2$$

$$u = 0$$

6. At Level B-B (Bottom Side):

$$\bar{\sigma} = 46.375 - 0 = 46.375 \text{ kN/m}^2$$

$$\sigma = 16.5625 \times (4 - 1.2) = 46.375 \text{ kN/m}^2$$

$$u = -1.2 \times 10 = -12 \text{ kN/m}^2$$

$$\bar{\sigma} = 46.375 - (-12) = 58.375 \text{ kN/m}^2$$

2-8 A (CE-Sem-5)

Soil Hydraulics

7. At Level C-C :

$$\sigma = 16.5625 \times 2.8 + (4 - 1.2) \times 18.44 = 68.503 \text{ kN/m}^2$$

$$u = 0$$

$$\bar{\sigma} = 68.503 - 0 = 68.503 \text{ kN/m}^2$$

8. At Level D-D :

$$\sigma = (4 - 1.2) \times 16.5625 + 1.2 \times 18.44 + 3 \times 20.3125 = 129.44 \text{ kN/m}^2$$

$$u = 3 \times 10 = 30 \text{ kN/m}^2$$

$$\bar{\sigma} = 129.44 - 30 = 99.44 \text{ kN/m}^2$$

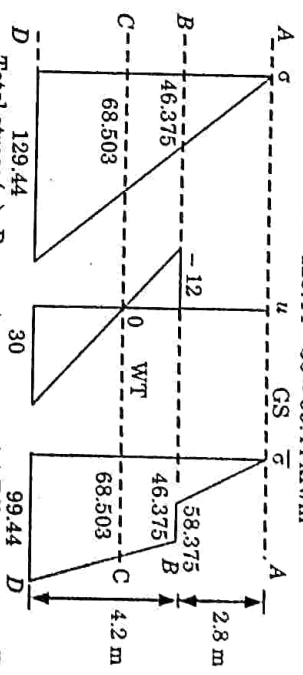

Fig. 2.6.2. Variation of σ , u and with the depth of deposit (All values are in kN/m²).

Que 2.7. Describe Darcy's law and give its validity.

Answer

Darcy's Law :

Darcy's law states that there is a linear relationship between flow velocity (v) and hydraulic gradient (i) for any given saturated soil under steady laminar flow conditions.

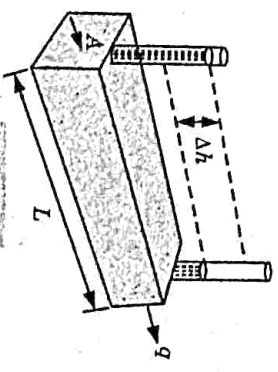

Fig. 2.7.1.

ii. If the rate of flow is q (volume/time) through cross-sectional area (A) of the soil mass, Darcy's Law can be expressed as :

$$v = Q/A = ki$$

where, k = Coefficient of permeability.
 i = Hydraulic gradient.
 M = Difference in total heads.
 L = Length of the soil mass.

Validity of Darcy's Law :

1. Darcy's law is valid if the flow through soils is laminar.
2. It is valid for flow in clays, silts and fine sands. In coarse sands, gravels and boulders, the flow may be turbulent and Darcy's law may not be applicable.
3. For Darcy's law to be valid, the relationship between velocity (v) and hydraulic gradient (i) should be linear.
4. In extremely fine-grained soils, such as colloidal clay, the interstices are very small. The velocity is therefore very small. In such soils, the Darcy's law is not valid.

Que 2.8. Define permeability. Explain the laboratory methods to find permeability coefficient. OR

What are different methods for determination of the coefficient of permeability in a laboratory ? Discuss their limitations.

AKTU 2017-18, Marks 10

Answer

- A. Permeability :** It is the property of a porous medium which permits slow movement of free or gravitational water (or other fluids) through its interconnecting voids.
- B. Laboratory Methods :** The coefficient of permeability of a soil can be determined by using the following methods :
 1. **Constant Head Permeability Test :**
 - i. Constant-head tests are used for estimating the coefficient of permeability of coarse-grained soils of high permeability, such as clean sands and gravel.
 - ii. Fig. 2.8.1 shows the arrangement in which the flow is one-dimensional and in downward direction.
 - iii. The figure also indicates the head loss (h_f) and the corresponding length of soil, L , over which the head loss occurs.
 - iv. The experimental data consist of a measured quantity of discharge Q during a time interval t , under steady state conditions of flow. The head loss h_f is also noted.
 - v. k can be computed from the formula,

$$k = \frac{QL}{h_f A t}$$

where,

Q = Quantity of discharge in time t .

h_f = Head loss over length L .

A = Area of cross-section of soil sample.

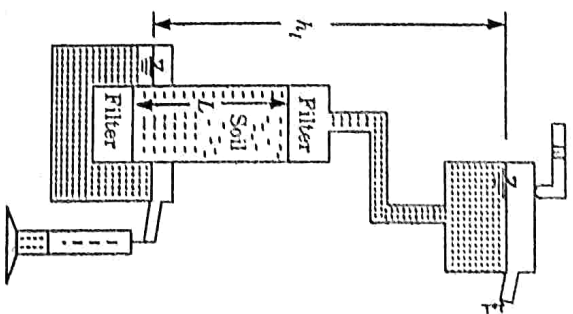

Fig. 2.8.1

Limitations : Following are the limitations of constant head permeability test:

- i. Equipment expensive.
 - ii. Complicated to set up and to use.
 - iii. Not suitable for most sites.
 - iv. Test duration long.
- 2. Falling or Variable Head Permeability Test :**
- i. Falling-head test are used for fine-grained soils with low permeability, such as silty or clayey fine sand, silts, and clays.
 - ii. A typical set-up for falling head permeability test is shown in Fig. 2.8.2. The water level in the stand pipe is observed from time to time. Let A be the area of soil sample, a the area of stand pipe and L the length of soil sample.
 - iii. If the head difference at time t_1 is h_1 and at time t_2 is h_2 , then coefficient of permeability is calculated from the expression.

$$k = \frac{aL}{A(t_2 - t_1)} \log_e \left(\frac{h_1}{h_2} \right)$$

Limitations : Test specimen cannot be consolidated to expected in-situ effective stress.

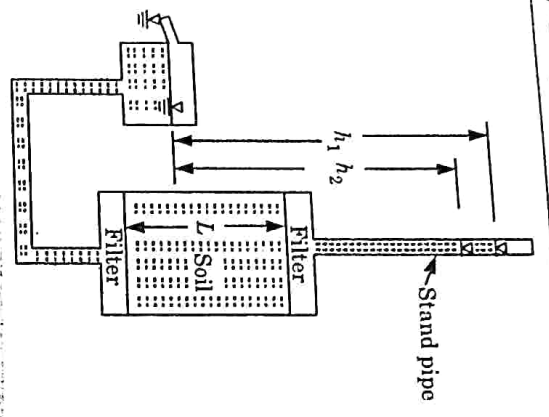

Fig. 2.8.2. Arrangement for variable-head permeability test

Que 2.9. A soil sample 90 mm high and 6000 mm² in cross-section as subjected to a falling-head permeability test. The head fell from 500 mm to 300 mm in 1500 sec. The permeability of the soil was 2.4 × 10⁻³ mm/sec. Determine the diameter of the stand pipe.

AKTU 2019-20, Marks 07

Answer

Given : Length of soil sample, $L = 90$ mm, Area of soil sample, $A = 6000$ mm², $h_1 = 500$ mm, $h_2 = 300$ mm, $\Delta t = t_2 - t_1 = 1500$ sec, Co-efficient of permeability, $k = 2.4 \times 10^{-3}$ mm/sec
To Find : Diameter of stand pipe.

1. According to falling head permeability test, coefficient of permeability is given by,

$$k = \frac{aL}{A(t_2 - t_1)} \ln \left(\frac{h_1}{h_2} \right)$$

$$2.4 \times 10^{-3} = \frac{a \times 90}{6000 \times 1500} \times \ln \left(\frac{500}{300} \right)$$

Area of stand pipe, $a = 469.83$ mm²

2. Diameter of stand pipe,

$$d = \left(\frac{4a}{\pi} \right)^{1/2} = \left(\frac{4 \times 469.83}{\pi} \right)^{1/2} = 24.458 \text{ mm}$$

Que 2.10. Give the expressions of the equivalent permeability for horizontal and vertical flow of water in soil medium.

Answer

A. Equivalent Permeability for Horizontal Flow of Water (Parallel to Bedding Plane) :

1. Let Z_1, Z_2, Z_3 are thickness of parallel soil layers, and k_1, k_2, k_3, \dots are permeabilities of layers.
 2. The total discharge through the deposit will be the sum of discharge through individual layers.

$$q = q_1 + q_2 + \dots + q_n$$

$$q = k_x i A$$

$$k_x i Z = k_1 i Z_1 + k_2 i Z_2 + k_3 i Z_3 + \dots + k_n i Z_n$$

$$k_x Z = k_1 Z_1 + k_2 Z_2 + k_3 Z_3 + \dots + k_n Z_n$$

$$k_x = \frac{k_1 Z_1 + k_2 Z_2 + k_3 Z_3 + \dots + k_n Z_n}{Z_1 + Z_2 + Z_3 + \dots + Z_n} \quad [\because Z = Z_1 + Z_2 + Z_3 + \dots + Z_n]$$

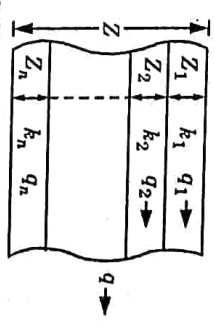

Fig. 2.10.1. Flow parallel to bedding plane.

B. Equivalent Permeability for Vertical Flow of Water (Perpendicular to Bedding Plane) :

1. For flow perpendicular to bedding plane the discharge q will be same for all layers.

2. Considering gross area of cross-section of flow, and the velocity of flow will be same for all layers.

3. The total head loss will be sum of head losses in individual layers.

$$h = h_1 + h_2 + h_3 + \dots + h_n$$

$$iZ = i_1 Z_1 + i_2 Z_2 + i_3 Z_3 + \dots + i_n Z_n$$

$$\frac{V}{k_x} Z = \frac{V}{k_1} Z_1 + \frac{V}{k_2} Z_2 + \frac{V}{k_3} Z_3 + \dots + \frac{V}{k_n} Z_n$$

$$\frac{Z}{k_x} = \frac{Z_1}{k_1} + \frac{Z_2}{k_2} + \frac{Z_3}{k_3} + \dots + \frac{Z_n}{k_n}$$

$$k_x = \frac{Z}{\frac{Z_1}{k_1} + \frac{Z_2}{k_2} + \frac{Z_3}{k_3} + \dots + \frac{Z_n}{k_n}}$$

7. The permeability parallel to stratification is much more than that perpendicular to stratification.

Que 2.11: Flow passes from one stratum of permeability k_1 to another stratum of permeability k_2 . If the deflection angle of the flow line at the interface is a_1 in the first stratum and the angle of deflection in the second stratum is a_2 . Then derive a relation between k_1, k_2, a_1 , and a_2 .

OR
When the flow lines pass from soil-1 to another soil-2 having a different permeability k_1 and k_2 ; they deviate from the interface of the two soils. Explain these two conditions; $k_1 > k_2$ and $k_1 < k_2$ with the help of neat sketches.

OR
Find out the expression for the law of deflection of flow line at the interface of two dissimilar soils.

AKTU 2018-19, Marks 07

Answer

Let the coefficients of the permeability of the two soils be k_1 and k_2 . We shall consider separately the two cases when (i) $k_1 > k_2$ and (ii) $k_1 < k_2$.
1. Fig. 2.11.1(a) shows the case when the soil (1) has permeability more than the soil (2).

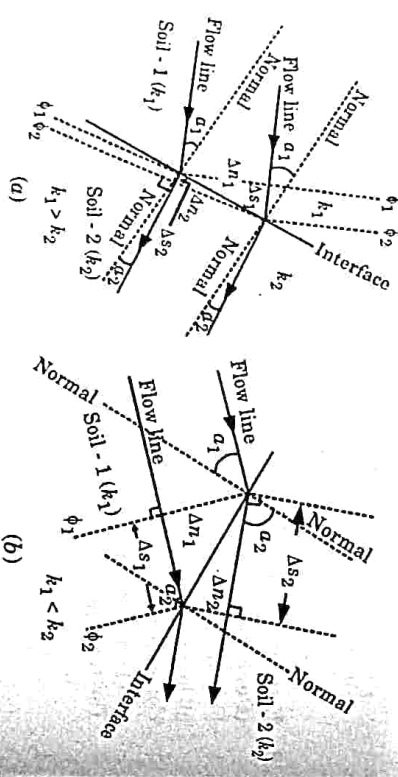

Fig. 2.11.1. Flownet in a non-homogeneous soil.

- The flow lines get deflected towards the normal after crossing the interface.
- The phenomenon of deflection of the flow lines is somewhat similar to refraction of light rays from a sparse medium to a dense medium.
- Let a_1 be the angle which the flow line makes with the normal in soil (1) and a_2 be the angle, in soil (2).
- Let ϕ_1 and ϕ_2 be the two equipotential lines.

6. The discharge through the flow channel between the two flow lines in two soils is given by,

$\Delta q_1 = k_1 (\Delta h / \Delta s_1) \Delta n_1$
and,
 $\Delta q_2 = k_2 (\Delta h / \Delta s_2) \Delta n_2$
For continuity of flow across the interface, the discharge through the flow channel remains the same. Therefore,

$$\Delta q_1 = \Delta q_2$$

$$k_1 (\Delta h / \Delta s_1) \Delta n_1 = k_2 (\Delta h / \Delta s_2) \Delta n_2$$

$$k_1 (\Delta n_1 / \Delta s_1) = k_2 (\Delta n_2 / \Delta s_2)$$

$$\frac{k_1}{\tan a_1} = \frac{k_2}{\tan a_2}$$

$$\frac{k_1}{k_2} = \frac{\tan a_2}{\tan a_1} \dots (2.11.1)$$

8. Eq. (2.11.1) must be satisfied at the interface by every flow line crossing it.

B. Case (ii), $k_1 < k_2$:
Fig. 2.11.1(b) shows the case when the flow takes place from a soil of low permeability to that of high permeability.

2. At the interface, the flow line is deflected away from the normal.
3. Using a procedure similar to that for the first case, it can be shown that

$$\frac{k_1}{\tan a_1} = \frac{k_2}{\tan a_2}$$

$$\frac{k_1}{k_2} = \frac{\tan a_2}{\tan a_1}$$

4. As $k_2 > k_1$, the angle a_2 is greater than angle a_1 and the flow line deflects away from the normal.

Que 2.12: A bed of sand consists of three horizontal layers of equal thickness. The magnitude of the coefficient of permeability for both the upper and lower layers is 4×10^{-1} mm/sec and for middle layer is 6×10^{-2} mm/sec. What is the ratio of average permeability of bed in horizontal direction to that in vertical direction?

AKTU 2015-16, Marks 10.

Answer

Given : Coefficient of permeability for first layer, $k_1 = 4 \times 10^{-1}$ mm/sec
Coefficient of permeability for second layer, $k_2 = 6 \times 10^{-2}$ mm/sec
Coefficient of permeability for third layer, $k_3 = 4 \times 10^{-1}$ mm/sec
To Find : Ratio of average permeability of bed in horizontal direction to vertical direction.

- Assume thickness of layers = Z
- Average coefficient of permeability in horizontal direction,

$$k_z = \frac{k_1 Z_1 + k_2 Z_2 + k_3 Z_3}{Z_1 + Z_2 + Z_3}$$

$$= \frac{4 \times 10^{-4} \times Z + 6 \times 10^{-2} \times Z + 4 \times 10^{-4} \times Z}{Z + Z + Z}$$

$$= \frac{4 \times 10^{-4} Z + 6 \times 10^{-2} Z + 4 \times 10^{-4} Z}{3Z}$$

$$k_z = \frac{Z[4 \times 10^{-4} + 6 \times 10^{-2} + 4 \times 10^{-4}]}{3Z} = 0.02 \text{ mm/sec}$$

2. Coefficient of permeability in vertical direction,

$$k_z = \frac{Z_1 + Z_2 + Z_3}{\frac{Z_1}{k_1} + \frac{Z_2}{k_2} + \frac{Z_3}{k_3}}$$

$$k_z = \frac{Z}{\frac{Z}{4 \times 10^{-4}} + \frac{Z}{6 \times 10^{-2}} + \frac{Z}{4 \times 10^{-4}}}$$

$$k_z = \frac{1}{\frac{1}{4 \times 10^{-4}} + \frac{1}{6 \times 10^{-2}} + \frac{1}{4 \times 10^{-4}}}$$

$$k_z = \frac{1}{\frac{1}{3} \left[\frac{1}{4 \times 10^{-4}} + \frac{1}{6 \times 10^{-2}} + \frac{1}{4 \times 10^{-4}} \right]} = 5.98 \times 10^{-4} \text{ mm/sec}$$

3. Now, the ratio of average permeability of bed,

$$\frac{k_z}{k_1} = \frac{0.02}{5.98 \times 10^{-4}} = 33.44$$

Que 2.13. Explain field methods to determine permeability.

Answer:

AKTU 2015-16, Marks 15

Field Methods: Following are the field methods to determining the permeability:

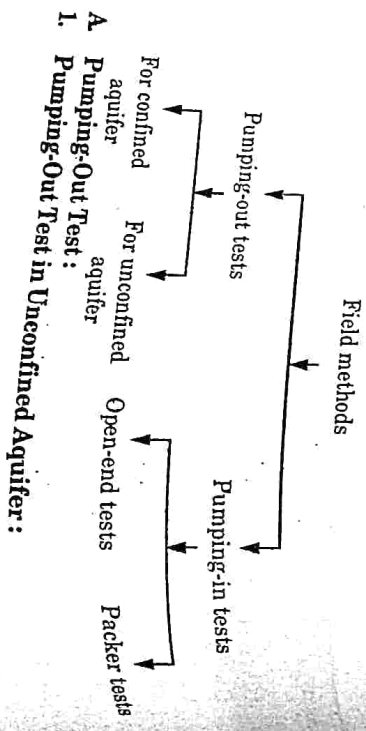

2-16A (CE-Sem-5)

Soil Hydraulics

- Let $P(x, y)$ be any point on the drawdown curve.
- The point O at the bottom of central axis of well is chosen as the origin of reference.
- Applying Darcy's law,

$$q = h A_i \quad i_z = k(2\pi r y) \frac{dy}{dx}$$

$$\frac{q}{x} dx = 2\pi k y dy \quad \dots(2.13.1)$$

iv. Now, integrating the eq. (2.13.1), we get

$$q \int_r^R \frac{dx}{x} = 2\pi k \int_h^H y dy$$

$$q \log_e \frac{R}{r} = 2\pi k \frac{(H^2 - h^2)}{2}$$

$$k = \frac{q}{\pi(H^2 - h^2)} \log_e \frac{R}{r}$$

where,

- r = Radius of main well.
- R = Radius of zero drawdown curve.
- h = Depth of water in main well.

v. To avoid the use of R , an alternative method is used to measure drawdown s_1 and s_2 in two observation wells located at radial distance r_1 and r_2 from the axis of main well.

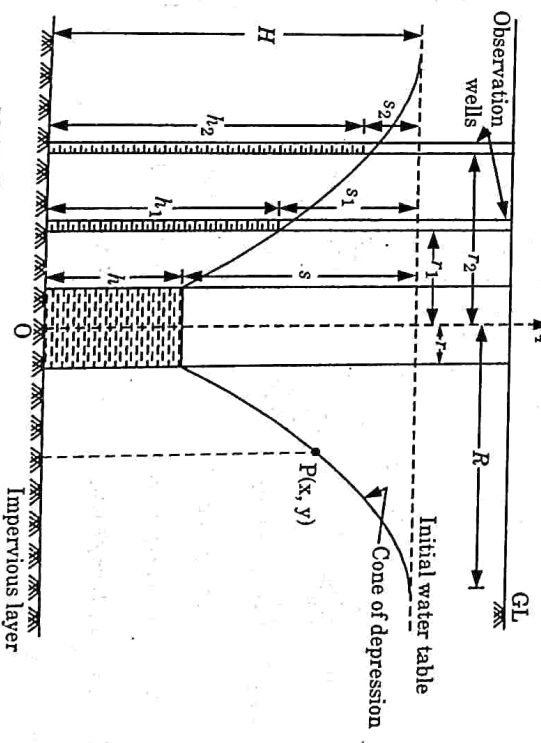

Fig. 2.13.1. Pumping-out test in unconfined aquifer.

vii. The depth of water in the two observation wells is:
 $h_1 = H - s_1$

$$h_2 = H - s_2$$

- vii. Now, $y = h_1$ at $x = r_1$
 $y = h_2$ at $x = r_2$
- viii. Therefore, integrate the eq. (2.13.1), we get

$$q \int_{r_1}^{r_2} \frac{dx}{x} = 2\pi k \int_{h_1}^{h_2} y dy$$

$$q \log_e \frac{r_2}{r_1} = 2\pi k \left(\frac{h_2^2 - h_1^2}{2} \right)$$

$$k = \frac{q}{\pi(h_2^2 - h_1^2)} \log_e \frac{r_2}{r_1}$$

2. Pumping-Out Test in Confined Aquifer :

- i. Let $P(x, y)$ be any point on the drawdown curve.

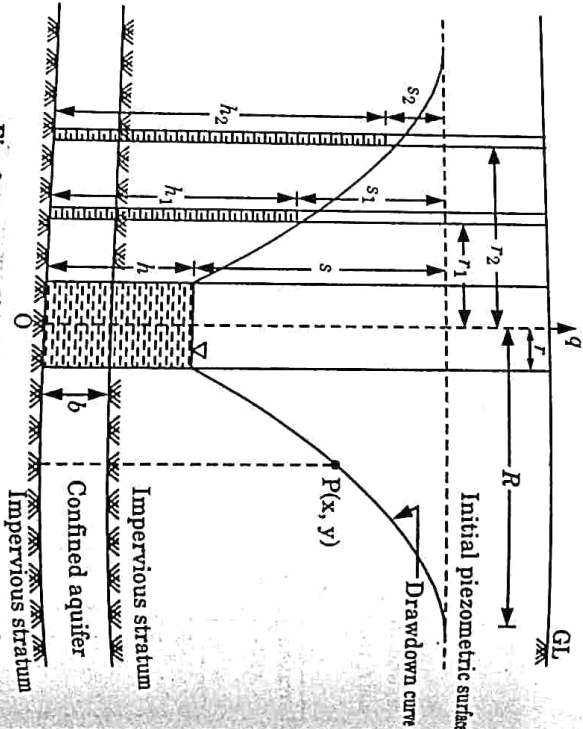

Fig. 2.13.2. Pumping-out test in confined aquifer.

- ii. The origin of reference O is chosen at the bottom of axis of main well.
- iii. By using Darcy's law, $q = kA_x i_x = k(2\pi b) \frac{dy}{dx}$

$$\frac{q}{x} = 2\pi b k dy$$

- iv. Now, integrating $q \int_{r_1}^{r_2} \frac{dx}{x} = 2\pi b k \int_{h_1}^{h_2} dy$

- v. Alternatively, if h_1 and h_2 are the depths of water measured above bottom impervious stratum in two observation wells located at radial distance r_1 and r_2 from the axis of main well, then we can write

$$k = \frac{q}{2\pi b(H - h)} \log_e \frac{r_2}{r_1}$$

$$q \int_{r_1}^{r_2} \frac{dx}{x} = 2\pi k b \int_{h_1}^{h_2} dy$$

$$q \log_e \frac{r_2}{r_1} = 2\pi b k (h_2 - h_1)$$

$$k = \frac{q}{2\pi b (h_2 - h_1)} \log_e \frac{r_2}{r_1}$$

B. Pumping in Tests :

- 1. **Open-End Test :**
 In this method, an open end pipe is shrunk in the medium and soil is taken out from it.

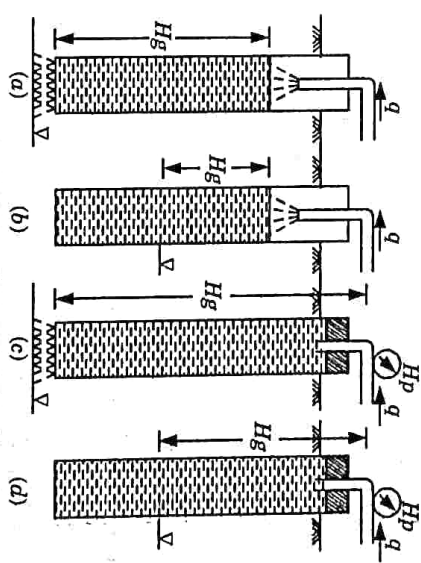

Fig. 2.13.3. Open-end tests.

- ii. Clean water having the temperature slightly greater than ground water is pumped into the medium through the pipe under constant head with the half of discharge measuring device.

$$k = \frac{q}{5.5 r h}$$

- iii. Differential head, h = Gravity head + Pressure head
- 2. **Packer Test :**
 The packer tests are commonly used for pressure testing of bedrock by using packers, but these tests can also be used for determining coefficient of permeability of soils.
- ii. For packer tests the expressions for the coefficient of permeability are :
 a. If $L \geq 10 r$

$$k = \frac{q}{2\pi L h} \log_e \left(\frac{L}{r} \right)$$

$$r \leq L < 10r$$

$$k = \frac{q}{2\pi L h} \sin h^{-1} \left(\frac{L}{2r} \right)$$

where,
 h = Differential head.
 r = Radius of bore hole.
 L = Length of the test section.

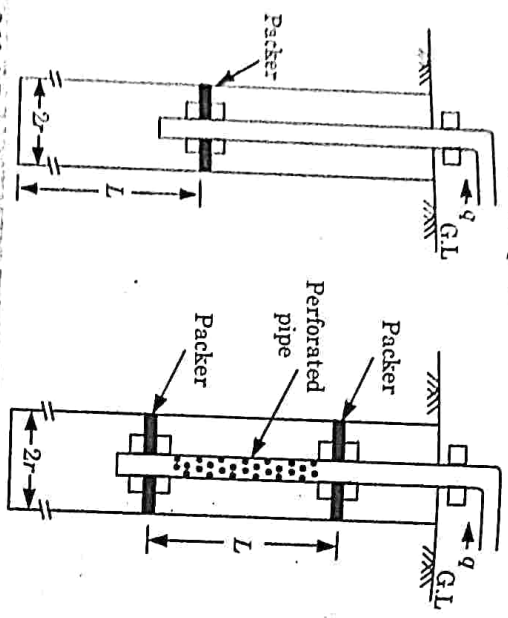

Fig. 2.13.4. Pumping in test - single and double packer method.

Que 2.14 Discuss the factors that influence permeability of soil.

Answer

- Following are the factors affecting the permeability of soils :
- Properties of Pore Fluid :**
 Pore fluids are fluids that occupy pore spaces in a soil or rock. Permeability is directly proportional to the unit weight of pore fluid and inversely proportional to viscosity of pore fluid.
 - Void Ratio :** Increase in the void ratio increases the area available for flow hence permeability increases for critical conditions.
 - Entrapped Air and Organic Impurities :** The organic impurities and entrapped air obstruct the flow and coefficient of permeability is reduced due to their presence.
 - Adsorbed Water :** Adsorbed water means a thin microscopic film of water surrounding individual soil grains.
 - Free Water :** This water is not free to move and hence reduces the effective pore space and thus decreases coefficient of permeability.

2-20A (CE-Sem-6)

Soil Hydraulics

- Shape of Particles :** Permeability is inversely proportional to specific surface $e.g.$, as angular soil have more specific surface area compared to the round soil therefore, the soil with angular particles is less permeable than soil of rounded particles.

PART-2

Seepage, Flownets, Seepage Calculation from a Flownets, Flownets in Anisotropic Soils, Seepage Through Earth Dam, Capillarity, Critical Hydraulic Gradient and Quick Sand Condition, Uplift Pressure, Piping.

Questions-Answers

Long Answer Type and Medium Answer Type Questions

Que 2.15. What is flownet ? What are the salient characteristics of a flownet ?

Answer

A. Flownet : A grid obtained by drawing a series of equipotential lines and stream lines is known as flownet.

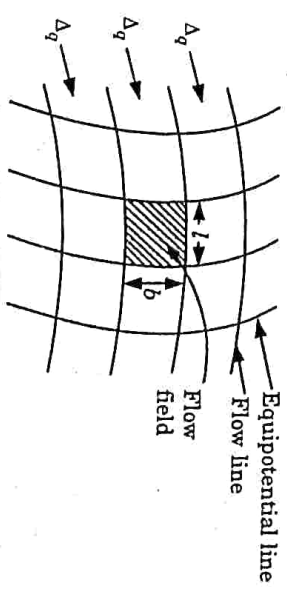

Fig. 2.15.1. Portion of a flownet.

- B. Characteristics / Properties of Flownet :** Following are the characteristics of a flownet :
- Equipotential lines and stream lines intersect each other orthogonally in a flownet.
 - There can be no flow across the flow line and velocity of flow is always perpendicular to equipotential line.
 - Loss of head between two equipotential lines is always same and is termed as equipotential drop.
 - Area bounded between two equipotential lines and flow lines is known as flow fields which are approximately square in isotropic medium, while in non isotropic medium, they are approximately rectangular.

- The area between two flow lines is known as flow channel and discharge through each flow channel is same.
- If water level are reversed on upstream and downstream side without change in boundary condition, there is no change in flow net i.e., flow net is unique for given set of boundary conditions.

Que 2.16. Explain flow net. Describe its properties and its applications.

AKTU 2019-20, Marks 07

Answer

- A. Flow net and Properties :** Refer Q. 2.15, Page 2-20A, Unit-2.
- B. Application :** Flow net is used to :
- Estimation of seepage losses from reservoir.
 - Determination of seepage pressure.
 - Uplift pressure below dams.
 - To check against the possibility of piping and many others.

Que 2.17. How would you determine seepage by using flow net?

Answer

- Let Δq be the discharge through each flow channel taking place under the head H and considering unit length of flow field in the plane.
- $$\Delta q = A_1 v_1 = A_2 v_2 = A_n v_n$$

$$= (b_1 \times 1) v_1 = (b_2 \times 1) v_2 = (b_n \times 1) v_n$$

$$b_1 v_1 = b_2 v_2 = b_n v_n$$
- Total discharge,
$$q = \Delta q N_f$$

N_f = Number of flow lines - 1
- $$\Delta h = \frac{H}{N_d}$$

N_d = Number of equipotential lines - 1
- Flow net can be used for determination of seepage, seepage pressure, hydraulic pressure and exit gradient.
- Discharge is given by, $\Delta q = k i \Delta$

$$\Delta q = k \frac{\Delta h}{e} (b \times 1)$$

$$\Delta q = k \Delta h \frac{b}{e}$$

$$\Delta q = k \Delta h$$

$$\Delta q = k \frac{H}{N_d}$$

$$q = \Delta q N_f = \frac{kH}{N_d} N_f = kH \left(\frac{N_f}{N_d} \right)$$

8.

7. For isotropic medium, $b = e$

$$\Delta q = k \Delta h$$

$$\Delta q = k \frac{H}{N_d}$$

$$q = \Delta q N_f = \frac{kH}{N_d} N_f = kH \left(\frac{N_f}{N_d} \right)$$

2-22 A (CE-Sem-5)

Soil Hydraulics

$$\frac{N_f}{N_d} = \text{Shape factor}$$

Determination of Seepage Pressure at a Point :

1. Seepage pressure (p_s) at a point is given by,

where,

$$p_s = h' \gamma_w$$

h = Total head at the point = $(H - n\Delta h)$.

H = Total head causing flow.

n = Number of potential drops upto the point under consideration.

$$\Delta h = \text{Potential drop per field} = \frac{H}{N_d}$$

Que 2.18. What are the properties of a flow net? Also derive an expression for the Laplace's equation of continuity for the two dimensional seepage flow.

OR

Drive the Laplace's equation of continuity with all assumptions.

AKTU 2016-17, Marks 10

Answer

- A. Properties of Flow net :** Refer Q. 2.15, Page 2-20A, Unit-2.
- B. Assumptions made for Deriving the Laplace Equation :**
- The flow is two dimensional.
 - Water and soil are incompressible.
 - Soil is isotropic and homogeneous.
 - The soil is fully saturated.
 - The flow is steady, i.e., flow conditions do not change with time.
 - Darcy's law is valid.
- C. Derivation :**
- Let us consider an element of soil of size dx by dz through which flow is taking place.
 - The third dimension along Y-axis is large. For convenience, it is taken as unity.
 - Let the velocity at the inlet and outlet face be v_x and $\left(v_x + \frac{\partial v_x}{\partial x} dx \right)$ in

X-direction and v_z and $\left(v_z + \frac{\partial v_z}{\partial z} dz \right)$ in Z-direction.

4. As the flow is steady and the soil is incompressible, the discharge entering the element is equal to that leaving the element.

5. Thus, $v_x dz + v_z dx = \left(v_x + \frac{\partial v_x}{\partial x} dx \right) dz + \left(v_z + \frac{\partial v_z}{\partial z} dz \right) dx$

$$\left(\frac{\partial v_x}{\partial x} + \frac{\partial v_z}{\partial z} \right) dx dz = 0$$

or $\left(\frac{\partial^2 v_x}{\partial x^2} + \frac{\partial^2 v_z}{\partial z^2}\right) = 0$

...(2.18.1)

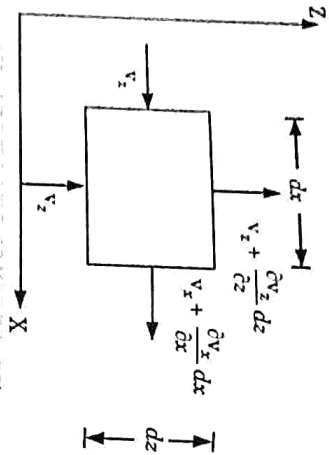

Fig. 2.18.1. Two-dimensional flow.

- Eq. (2.18.1) is the continuity equation for two-dimensional flow.
- Let h be the total head at any point. The horizontal and vertical components of the hydraulic gradient are,

$$i_x = \frac{-\partial h}{\partial x}, \text{ and } i_z = \frac{-\partial h}{\partial z}$$

- The minus sign indicates that the head decreases in the direction of flow.
- From Darcy's law,

$$v_x = -k_x \frac{\partial h}{\partial x}$$

$$v_z = -k_z \frac{\partial h}{\partial z}$$

- Substituting these values in eq. (2.18.1), we get

$$-k_x \frac{\partial^2 h}{\partial x^2} - k_z \frac{\partial^2 h}{\partial z^2} = 0$$

$$\text{or } k_x \frac{\partial^2 h}{\partial x^2} + k_z \frac{\partial^2 h}{\partial z^2} = 0$$

- As the soil is isotropic, $k_x = k_z$.

$$\text{Therefore, } \frac{\partial^2 h}{\partial x^2} + \frac{\partial^2 h}{\partial z^2} = 0$$

...(2.18.2)

- Eq. (2.18.2) is the Laplace equation in terms of head h .
- Sometimes the Laplace equation is represented in terms of velocity potential, ϕ is given by,

$$\phi = -hh$$

- Therefore,

$$\frac{\partial \phi}{\partial x} = v_x, \quad \frac{\partial \phi}{\partial z} = -k \frac{\partial h}{\partial z}$$

- Substituting the values of v_x and v_z in eq. (2.18.1), we get
- $$\frac{\partial^2 \phi}{\partial x^2} + \frac{\partial^2 \phi}{\partial z^2} = 0$$
- ...(2.18.3)
- Eq. (2.18.3) is the Laplace equation in terms of velocity potential.
- Que 2.19.** What are the assumption and limitations of Dupuit's theory ?
- Answer**
- A. Assumptions :** Following are the assumptions of Dupuit's theory :
- The flow is laminar and Darcy's law is valid.
 - The soil mass is isotropic and homogeneous.
 - The well penetrates the entire thickness of aquifer.
 - The flow is steady.
 - The coefficient of permeability remains constant throughout.
 - The flow towards the well is radial and horizontal.
 - Natural ground water regime remains constant.
- B. Limitations :** Various assumptions have been made in the Dupuit's theory formulae. In actual practice, however, none of these conditions may get fulfilled; say for example :
- An aquifer is not fully homogeneous.
 - The well might have been dug half way through the aquifer.
 - Permeability may not be uniform.
 - The ground water table may be inclined and thus, the base of the cone may not be a circle.
 - The equilibrium conditions might have not fully reached.
- Que 2.20.** Derive the equation to calculate seepage through earth dam.
- OR**
- Explain the Dupuit's solution for the calculation of seepage through an earth dam resting on an impervious base.**
- Answer**
- The quantity of seepage flow through the body of the dam may be calculated for two cases :
- When discharge angle, $\beta < 30^\circ$
 - When discharge angle, $30^\circ < \beta < 60^\circ$
- Here we assume discharge angle $\beta < 30^\circ$
- Seepage through Earth Dam with Discharge Angle less than 30° :**

- Geotechnical Engineering
- If the angle β is less than 30° (Fig. 2.20.1) point S at which the seepage line becomes tangential to downstream face can be obtained using Schaffernack's method.
 - It is assumed that part CS of the seepage line is a straight line.
 - A tangent at point S coincides over the length CS with the seepage line.

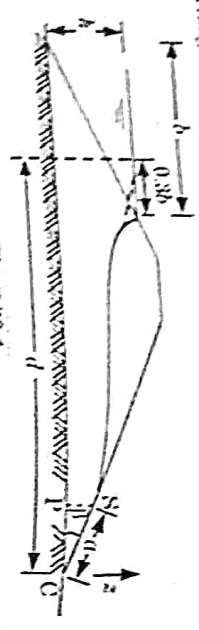

Fig. 2.20.1

- The discharge is given by,

$$q = kZ \frac{dz}{dx} \quad \dots(2.20.1)$$

- But $\frac{dz}{dx} = i = \tan \beta$

and $Z =$ distance $SP = a \sin \beta$, where $SC = a$

- Therefore, $q = k(a \sin \beta) \tan \beta \quad \dots(2.20.2)$

- From eq. (2.20.1) and (2.20.2), we get

$$kZ \frac{dz}{dx} = k a \sin \beta \tan \beta$$

or $Z dz = a \sin \beta \tan \beta dx$

- Integrating between $x = a \cos \beta$ to $x = d$, and between $Z = a \sin \beta$ to h ,

$$\int_{a \cos \beta}^d Z dz = a \sin \beta \tan \beta \int_{a \cos \beta}^d dx$$

$$\frac{1}{2} (h^2 - a^2 \sin^2 \beta) = a \sin \beta \tan \beta (d - a \cos \beta)$$

$$h^2 - a^2 \sin^2 \beta = 2a \frac{\sin^2 \beta}{\cos \beta} (d - a \cos \beta)$$

$$\frac{h^2 \cos \beta}{\sin^2 \beta} - a^2 \cos \beta = 2ad - 2a^2 \cos \beta$$

$$a^2 \cos \beta - 2ad + \frac{h^2 \cos \beta}{\sin^2 \beta} = 0$$

- From eq. (2.20.3), we get

$$a = \frac{2d \pm \sqrt{4d^2 - 4(h^2 \cos \beta / \sin^2 \beta) \cos \beta}}{2 \cos \beta}$$

$$a = \frac{d}{\cos \beta} \frac{h^2}{\cos^2 \beta \sin^2 \beta} \quad \dots(2.20.4)$$

- Once the value of α has been determined from eq. (2.20.4), the discharge can be found using eq. (2.20.2).

Que 2.21. Why in there more likelihood of 'quick condition' in sands than in clays? Also derive the expression for critical hydraulic gradient.

OR

Explain how upward flow of seepage water causes the effective stress. What is the role of the pore water pressure in the quick sand condition? **AKTU 2017-18, Marks 10**

Answer

- When flow takes place in upward direction, seepage pressure also acts vertically upward which results in decrease of effective pressure in the soil.
- If seepage pressure is such that it equals the submerged weight of soil, effective stress reduces to zero.
- In such condition shear strength of cohesionless soil mass is zero and soil particles have tendency to flow with water.
- In this process, soil particles leave the soil mass.
- This condition is called quick sand condition.

$$\bar{\sigma} = Z\gamma' - p_s = 0$$

$$Z\gamma' = p_s$$

$$Z\gamma' = iZ\gamma_w$$

$$i = i_c = \frac{\gamma'}{\gamma_w} = \frac{(G-1)\gamma_w}{(1+e)\gamma_w}$$

$$i_c = \frac{G-1}{1+e}$$

$$i_c = \frac{2.65 - 1}{1 + 0.65} = \frac{1.65}{1.65} = 1$$

- The hydraulic gradient at which quick sand condition occurs is termed as critical gradient, piping gradient and floating gradient.
- For fine sand and silt, specific gravity is approximately 2.65 and void ratio 0.65, then critical gradient is approximately unity.

- To avoid quick sand condition ' i ' should be less than critical hydraulic gradient.

Hence, $FOS = \frac{i_c}{i}$

- In cohesive soils like clay due to their inherent cohesion, shear strength is not reduced to zero even if effective stress reduces to zero.
- Hence particles in the cohesive soils are held due to inherent cohesion and does not leave the soil mass even if effective stresses becomes zero.

$$\tau = c + \bar{\sigma} \tan \phi$$

$$\tau = c \quad \text{if } \bar{\sigma} = 0$$

Que 2.22 Write a short note on :

- i. Capillarity.
- ii. Uplift pressure.

Answer:

A. Capillarity :

1. The height above the water table to which the soil is saturated is called capillary rise and this phenomenon called capillarity.
2. Above the water table, when the soil is saturated, pore pressure will be negative (less than atmospheric).
3. Capillary depends on the grain size and the size of pore.
4. In coarse grained soils the capillary rise is very small compare to fine grained soils.

B. Uplift Pressure :

1. Uplift pressure at any given point is the pore water pressure acting vertically upward due to the residual pressure head at that point.
2. The diagram of distribution of uplift pressure along the base of the dam can be drawn and the total uplift force then calculated by working out the area of the uplift pressure distribution diagram.
3. Uplift force is an important consideration in the stability of a masonry dam.
4. The total uplift force acts opposite the force of gravity due to the weight of the dam and hence reduces the stability of the hydraulic structure.
5. Uplift pressure along the base of masonry dams can be effectively reduced by providing vertical cut off walls at the upstream end of the base of the dam.

Que 2.23. What is piping in hydraulic structure ? Suggest some remedial measure to check or prevent it.

Answer

A. Piping :

1. It is a phenomenon which occurs due to erosion by sub-surface water moving through a soil mass.
2. It results in the formation of continuous tunnels or pipe-like formations through which soil is carried by flowing water and piping failure may occur.

B. Preventions of Piping Failures :

1. The following measures are generally adopted to prevent piping failures :
 1. Increasing the Path of Percolation :

AKTU 2015-16, Marks 10

2-28 A (CE-Sem-5)

Soil Hydraulics

- i. The hydraulic gradient (i) depends upon the path of percolation (L). If the length of the path is increased, the exit gradient will decrease to a safe value.
- ii. The length of the path of percolation can be increased by adopting the following methods :
 - a. Increasing the base width of the hydraulic structure.
 - b. Providing vertical cut off walls below the hydraulic structure.
 - c. Providing an upstream impervious blanket, as shown in Fig. 2.23.1.

2. Reducing Seepage :

- i. With a reduction of seepage through the dam, the chances of piping failure through the body of the dam are considerably reduced.
- ii. The quantity of seepage discharge is reduced by providing an impervious core, as shown in Fig. 2.23.1.

3. Providing Drainage Filter :

- i. A drainage filter changes the direction of flow away from the downstream face.
- ii. It prevents the movement of soil particles along with water.
- iii. The drainage filter may be horizontal or in the form of a rock toe. It may also be in the form of a chimney drain, as shown in Fig. 2.23.1.
- iv. A chimney drain is effective for stratified soil deposits in which the horizontal permeability is greater than the vertical permeability.

4. Loaded Filter :

- i. A loaded filter consists of graded sand and gravels. The function of the loaded filter is to increase the downward force without increasing the upward seepage force.
- ii. The loaded filter is placed at the exit point where the water emerges from the foundation.
- iii. For the sheet pile wall, the filter is placed over the affected zone.
- iv. The loaded filter increases the factor of safety against heave piping. The factor of safety (F) is given by,

$$F = \frac{W' + W}{U}$$

- v. where W is the weight of filter.
- v. The loaded filter should be of pervious material such that it does not increase the hydrostatic pressure. It should only increase the downward force.

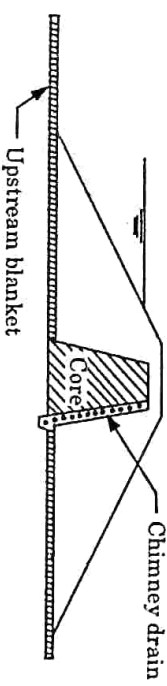

Fig. 2.23.1. Prevention of piping.

Que 2.24. Explain capillary siphoning with neat sketch. Also discuss about partially saturated soil. **AKTU 2018-19, Marks 07**

Answer

Capillary Siphoning :

1. In an earth dam with an impervious core, capillary siphoning may occur as shown in Fig. 2.24.1.

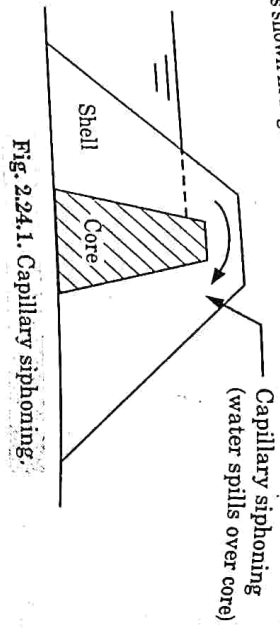

Fig. 2.24.1. Capillary siphoning.

2. The water rises in the outer shell due to capillary action. If the crest (top level) of the impervious core is in the reach of capillary rise, water flows from the storage reservoir to the downstream over the core.
 3. Considerable quantity of stored water may be lost to capillary siphoning.
 4. To prevent this, the crest of the impervious core should be kept sufficiently high.
 5. In other words, the difference of top level of the core and water level in the reservoir should be more than the capillary rise in soil of the shell.
- Partially Saturated Soil :**
1. Generally the soil is made up of three phases, which are called as soil solid, water and air.
 2. If the pore or void space in the soil is fully occupied by the water, then it is fully saturated.
 3. If the voids space in the soil is partially occupied by water, the pore is said to be partially saturated.
 4. It is found using the degree of saturation value.
 5. If the value is in between 0 to 100 %, then the soil is partially saturated.

Que 2.25. As a geotechnical engineer for the design of a filter of an earth dam, the proper selection of filter material is required to prevent the piping failure, so what are the conditions, you will keep in your mind at the time of filter design? **AKTU 2017-18, Marks 10**

Answer

1. When seepage water flows from a soil with relatively fine grains into coarser material, there is a danger that the fine soil particles may wash away into the coarse material.

2. Over a period of time, this process may clog the void spaces in the coarser material.

3. Such a situation can be prevented by the use of a filter or protective filter between the two soils.

4. For example, consider the earth dam section shown in Fig. 2.25.1. If rock fills were only used at the toe of the dam, the seepage water would wash the fine soil grains into the toe and undermine the structure. Hence, for the safety of the structure, a filter should be placed between the fine soil and the rock toe as shown in Fig. 2.25.1.

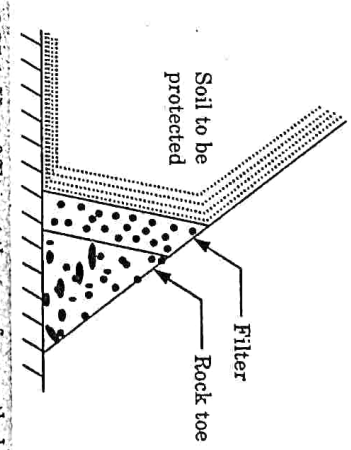

Fig. 2.25.1. Use of filter at the toe of an earth dam.

7. For the proper selection of the filter material, two conditions should be kept in mind :
 - i. The size of the voids in the filter material should be small enough to hold the larger particles of the protected material in place.
 - ii. The filter material should have a high permeability to prevent building of large seepage forces and hydrostatic pressure in the filter.
 - iii. The filter material specifications are given below :

$$\frac{D_{15} \text{ (filter)}}{D_{85} \text{ (protected material)}} < 5$$

$$\frac{D_{15} \text{ (filter)}}{D_{15} \text{ (protected material)}} < 20$$

$$\frac{D_{50} \text{ (filter)}}{D_{50} \text{ (protected material)}} < 25$$

D_{15} , D_{50} and D_{85} refer to the particle sizes from the grain size distribution curves.

Que 2.26. Describe the uses of flownet.

Answer

1. The flownet can be used for a number of purposes as given below :

Discharge : The space between two adjacent flow lines is called a flow channel. Let N_f be the number of flow channels. The difference between

two adjacent equipotential lines is called equipotential drop. Let N_p be the number of equipotential drops.

$$Q = KH(N/N_p)$$

2. **Total Head :** The loss of head (Δh) from one equipotential line to the next is h/N_p . The total head at any point can be determined as :

$$h = h - n \times (h/N_p)$$

3. **Pressure Head :** The pressure at any point is equal to the total head minus the elevation head.

The pressure head is given by,

$$h_p = h - (-h_e) = h + h_e$$

$$h_p = \text{Pressure head at } P.$$

$$h_e = \text{Elevation head at } P.$$

$$h = \text{Total head.}$$

4. **Hydraulic Gradient :** The average value of hydraulic gradient for any flow field is given by,

$$i = \Delta h / \Delta s$$

$$\Delta s = \text{Length of the flow.}$$

$$\Delta h = \text{Loss of head.}$$

VERY IMPORTANT QUESTIONS

Following questions are very important. These questions may be asked in your SESSIONALS as well as UNIVERSITY EXAMINATION.

- Q. 1. In a cohesionless soil deposit, the water table is at the ground surface. If the saturated unit weight is 18 kN/m³, compute the total stress, pore pressure and effective stress at a depth of 5 m, for the upward flow under a gradient of 0.5.

Ans: Refer Q. 2.2, Unit-2.

- Q. 2. A granular soil deposit is 7 m deep over an impermeable layer. The ground water table is 4 m below the ground surface. The deposit has a zone of capillary rise of 1.2 m with a saturation of 50%. Plot the variation of total stress, pore water pressure and effective stress with the depth of deposit, $e = 0.6$ and $G = 2.65$.

Ans: Refer Q. 2.6, Unit-2.

- Q. 3. Describe Darcy's law and give its validity.

Ans: Refer Q. 2.7, Unit-2.

- Q. 4. Define permeability. Explain the laboratory methods to find permeability coefficient.

Ans: Refer Q. 2.8, Unit-2.

- Q. 5. Flow passes from one stratum of permeability k_1 , to another stratum of permeability k_2 . If the deflection angle of the flow line at the interface is α_1 in the first stratum and the angle of deflection in the second stratum is α_2 . Then derive a relation between k_1, k_2, α_1 , and α_2 .

Ans: Refer Q. 2.11, Unit-2.

- Q. 6. A bed of sand consists of three horizontal layers of equal thickness. The magnitude of the coefficient of permeability for both the upper and lower layers is 4×10^{-4} mm/sec and for middle layer is 6×10^{-2} mm/sec. What is the ratio of average permeability of bed in horizontal direction to that in vertical direction?

Ans: Refer Q. 2.12, Unit-2.

- Q. 7. Explain field methods to determine permeability.

Ans: Refer Q. 2.13, Unit-2.

- Q. 8. What is flownet? What are the salient characteristics of a flownet?

Ans: Refer Q. 2.15, Unit-2.

- Q. 9. What are the assumption and limitations of Dupuit's theory?

Ans: Refer Q. 2.19, Unit-2.

- Q. 10. Why is there more likelihood of 'quick' condition in sands than in clays? Also derive the expression for critical hydraulic gradient.

Ans: Refer Q. 2.21, Unit-2.

- Q. 11. What is piping in hydraulic structure? Suggest some remedial measure to check or prevent it.

Ans: Refer Q. 2.23, Unit-2.

- Q. 12. As a geotechnical engineer for the design of a filter of an earth dam, the proper selection of filter material is required to prevent the piping failure, so what are the conditions, you will keep in your mind at the time of filter design?

Ans: Refer Q. 2.25, Unit-2.



3 UNIT

Soil Compaction and Consolidation

CONTENTS

Part-1 : Soil Compaction, 3-2A to 3-9A
Water Content-dry Unit,
Weight Relationships,
Factors Controlling Compaction,
Field Compaction Equipment,
Field Compaction Control,
Proctor Needle Method

Part-2 : Consolidation : Primary and 3-10A to 3-28A
Secondary Consolidation,
Terzaghi's One Dimensional
Theory of Consolidation,
Consolidation Test,
Normal and Over Consolidation Soils,
Over Consolidation Ratio,
Determination of Coefficient
of Consolidation

3-2 A (CE-Sem-5)

Soil Compaction & Consolidation

PART-1

*Soil Compaction, Water Content-Dry Unit Weight Relationships,
Factors Controlling Compaction, Field Compaction Equipment,
Field Compaction Control, Proctor Needle Method.*

Questions-Answers

Long Answer Type and Medium Answer Type Questions

Que 3.1. What is compaction ? What kind of improvement of the engineering properties of a soil mass can be brought about through compaction ?

Answer

- A. Compaction :** It means pressing the soil particles close to each other by mechanical methods. During compaction, air is expelled from the void space in the soil mass.
- B. Effects of Compaction on Engineering Properties of Soil :** Following are the engineering properties affected by the compaction of soil.
- 1. Permeability :** The effect of compaction is to decrease the permeability. In the case of fine grained soils it has been found that for the same dry density soil compacted wet of optimum will be less permeable than that of compacted dry of optimum.
 - 2. Compressibility :** In case of soil samples initially saturated and having same void ratio, it has been found that in low pressure range a wet side compacted soil is more compressible than a dry side compacted soil, and vice versa in high pressure range.
 - 3. Pore Pressure :**
 - i. Undrained shear test** conducted on saturated samples of clay it has been found that lower pore pressures develop at low strains when the sample is compacted dry of optimum, compared to the case when the sample is compacted wet of optimum.
 - ii. But at high strains** in both types of samples the development of pore pressure is same for same density and water content.
 - 4. Stress-Strain Relation :** Samples compacted dry of optimum produce much steeper stress-strain curves with peaks at low strains, whereas samples compacted wet of optimum, having the same density, produce much flatter stress-strain curves with increase in stress even at high strains.

- K. Shrinkage and Swelling :**
- At same density a soil compacted dry of optimum shrinks appreciably less than that of compacted wet of optimum.
 - Also the soil compacted dry of optimum exhibits greater swelling characteristics than samples of the same density compacted wet of optimum.

Que 3.2. What are the factors that affect the compaction ?

Answer

Factors Affecting the Compaction : Following are factors that affect the compaction :

- Water Content :** As the water content is increased, the compacted density goes on increasing, till a maximum dry density is achieved after which further addition of water decreases the density.
- Amount of Compaction :**
 - The amount of compaction greatly affects the maximum dry density and optimum water content of a given soil.
 - The effect of increasing the compactive energy results in an increase in the maximum dry density and decrease in the optimum water content.
- Method of Compaction :** The density obtained during compaction, for a given soil, greatly depends upon the type of compaction or the manner in which the compactive effort is applied.
- Type of Soil :** The maximum dry density achieved corresponding to a given compactive energy largely depends upon the type of soil.
- Admixture :**
 - The compaction characteristics of the soils are improved by adding other materials known as admixtures.
 - The most commonly used admixtures are lime, cement and bitumen.

Que 3.3. Explain the field methods for compaction of soil in details.

AKTU 2016-17, Marks 16

OR

What are various types of field compacting equipments ? Which types of rollers are suited for clayey and gravel soils ? Also give specifications of such rollers.

Answer

Method of Compaction : The three methods of compaction used in practice are ramming, rolling and vibrations.

A. Ramming :

- In this method of soil compaction, tampers are used.
- A hand-operated tamper (or rammer) consists of a block of iron (or stone), about 3 to 5 kg in mass, attached to a wooden rod. The tamper is lifted for about 0.30 m and dropped on the soil to be compacted.
- A mechanical rammer is operated by compressed air or gasoline power.

It is much heavier, about 30 to 150 kg. Mechanical rammers have been used upto a mass of 1000 kg in some special cases. Tampers are used to compact soils adjacent to existing structures or confined areas, such as trenches and behind the bridge abutments, where other methods of compaction cannot be used.

- Owing to very low output, tampers are not economical where large quantities of soils are involved. Tampers can be used for all types of soils.

Rolling : Rolling of soil is done by various types of rollers.

B. Smooth Wheel Roller :

- A smooth-wheel roller generally consists of three wheels; two large wheels in the rear and one small wheel in the front.
- A tandem type smooth-wheel roller consists of only two drums; one in rear and one in the front.

The mass of a smooth-wheel roller generally varies between 2 to 15 Mg. In these types of rollers compaction is achieved by the application of pressure over the soil mass.

These are generally suitable for **crushed stones, gravel and sand** (coarse grained soil).

This is generally used for road construction.

Sheep Foot Roller :

This type of roller has many round and rectangular shaped projections or feet attached to a steel drum.

One foot has 50 to 100 cm² surface area and 150 to 250 mm feet projection from the drum surface.

As the coverage is about 8 to 12 %, very high contact pressure, ranging from 1400 to 7000 kPa, depending upon the size of drum and whether the drum is partly or fully filled by water or sand.

This type of roller compaction is achieved by kneading action which provides comparatively stronger bond between compacting layers of the soil mass.

These are generally used for the construction of core of earthen dam (cohesive soils such as clay and silt).

Pneumatic Tyred Roller :

This type of roller consists of a box or platform mounted between two axles. The rear axle has one wheel more than at the front.

This roller has about 80 % coverage, i.e., 80 % of the total area is covered by tyres.

The tyre pressure in small rollers is of the order of 250 kPa where as in heavier rollers, it may range between 400 and 1050 kPa.

The soils are usually compacted in about 200 mm thick layers with 8 to 10 passes of the rollers.

In these rollers, compaction is achieved by use of both pressure and kneading action.

These are suitable for all types of soil but are generally used for cohesive soils.

These are used for construction of air fields, roadways and earthen dams.

C. Vibrations :

1. It is done by vibratory compactors. In vibratory compactors, vibrations are induced in the soil during compaction.
2. The compactors are available in a variety of forms. When the vibrator is mounted on a drum, it is called a vibratory roller. These rollers are available both as pneumatic type and the smooth-wheel type.
3. In a smooth-wheel type, a separate motor drives an arrangement of eccentric weights to create high frequency, low amplitude, up-and-down oscillations of the drum. These rollers are suitable for compacting granular soils, with no fines, in layers upto 1 m thickness.
4. In a pneumatic-tyred vibratory compactor, a separate vibrating unit is attached to the wheel axle. The ballast box is suspended separately from the axle so that it does not vibrate. These compactors are suitable for compacting granular soils with thickness of layer of about 30 cm.
5. Another form of a vibratory compactor is a vibrating-plate compactor. In this system, there are number of small plates, each plate is operated by a separate vibrating unit. Hand-operated vibrating plates are also available. The effect of the vibrating plates is limited to small depths.
7. The main use is to compact granular base courses for highways and runways where the thickness of layers is small.
8. Vibratory compactors can compact the granular soils to a very high maximum dry density.

Que 3.4. Write a short note on :

- i. Field compaction control
- ii. Proctor needle method.

AKTU 2016-17, Marks 10

OR

How will you perform the Proctor's needle test in a site for controlling the degree of compaction ?

OR

Let us suppose as a geotechnical expert, you have a challenge to control the compaction in a site; so how will you control the compaction by the Proctor's needle method ?

AKTU 2017-18, Marks 05

Answer

A. Field Control of Compaction :

- i. The field compaction control consists of the determination of:
 - ii. The water content at which the soil has been compacted, and
 - iii. The dry density (or dry unit weight) achieved.
- To attain a desired density by compaction, periodic measurements of moisture content and dry density will be required during the compaction process.

B. Methods : The methods for determining moisture content and dry density in the field, several methods are available :

1. Proctor needle method.
2. Core-cutter method.
3. Sand replacement method.
1. **Proctor Needle Method :**
- i. Used for rapid determination of moisture contents in-situ.
- ii. Equipment consists of a needle attached to a spring loaded plunger, calibrated to read penetration resistance in kg/cm².
- iii. Needle can have a suitable bearing area for the soil (larger bearing area for cohesive soils).
- iv. In the lab, sample is compacted in the mould and penetration resistance measured using Proctor needle.
- v. Water content and dry density is found.
- vi. The above process is repeated on the same sample for varying moisture contents.
- vii. Thus laboratory calibration curve is drawn.
- viii. To get moisture content in the site, sample of wet soil is compacted into the mould and penetration resistance read off from the Proctor needle.
- ix. Moisture content corresponding to the penetration resistance obtained from the laboratory calibration curve.

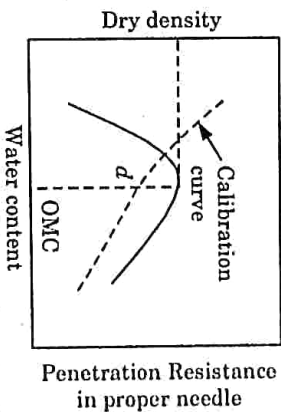

Fig. 3.4.1. Calibrated curve for needle.

Que 3.5. Describe standard Proctor test and modified Proctor test.

AKTU 2019-20, Marks 07

Answer

A. Standard Proctor Test :

1. To study the compaction characteristics, laboratory compaction tests have been developed.
2. The standard Proctor test developed by RR Proctor is widely used as a guide.
3. The equipments used in the test consist of:
 - i. Volume of mould = $\frac{1}{30}$ ft³ (945 ml).
 - ii. Weight of hammer = 2.495 kg

- iii. Collar - 2 inches (5 cm effective height).
 - 4. In this test, soil to be tested is filled in standard cylindrical mould of volume 1000 ml in three number of layers.
 - 5. Each layer is being computed by subjecting it to 25 blows with the help of hammer of weight 2.495 kg and free fall height of 304.8 mm.
- B. Modified Proctor Test:**

- 1. In this test soil is filled in standard cylindrical mould of volume $\frac{1}{30}$ ft³ or 945 ml in five numbers of layer.

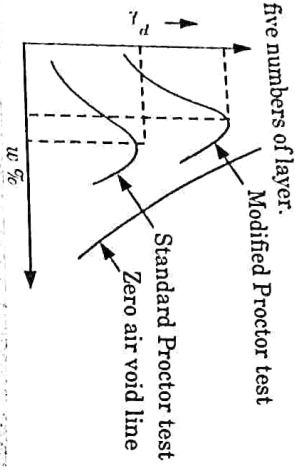

Fig. 3.5.1. Comparison of compaction curves.

- 2. Each layer is subjected to 25 number of blows with the help of hammer having total weight of 4.54 kg and free fall height of 457.2 mm.
- 3. After compacted soil, its sample from the mould is collected to find the water content at which compaction was carried out, which further utilized to compute the degree of compactness in terms of unit weight of soil.

$$\gamma_d = \frac{\gamma}{1+w}$$

Que 3.6. During the construction of an embankment, the density attained by field compaction was investigated by the sand jar method. A test pit was excavated in the newly compacted soil and was filled up by pouring sand. The following were the observations: Weight of soil excavated from pit = 2883 gm, weight of sand required to fill the pit = 2356 gm, bulk density of sand = 1.52 gm/cc, pit = 2356 gm, bulk density of sand = 1.52 gm/cc and moisture content of embankment soil = 16%. Determine the dry density of the compacted soil.

Answer

Given: Weight of soil excavated from pit = 2883 gm, Weight of sand required to fill the pit = 2356 gm, Bulk density of sand = 1.52 gm/cc, Moisture content of embankment soil, $w = 16\%$
To Find: Dry density of soil.

1.
$$\text{Volume of sand, } V = \frac{\text{Mass}}{\text{Density}} = \frac{2356}{1.52} = 1550 \text{ cm}^3$$

- 2. Bulk density of soil excavated,

$$\rho_{\text{soil}} = \frac{\text{Weight of soil}}{\text{Volume of soil}} = \frac{2883}{1550} = 1.86 \text{ gm/cc}$$
- 3. Dry density of compacted soil,

$$\rho_d = \frac{\rho_{\text{soil}}}{1+w}$$

$$\rho_d = \frac{1.86}{1+0.16} = 1.604 \text{ gm/cc}$$

Que 3.7. The following observations were made in a standard proctor test:

Trial No.	1	2	3	4	5	6
Mass of Wet Soil (kg)	1.70	1.89	2.03	1.99	1.96	1.92
Water Content (%)	7.7	11.5	14.6	17.5	19.7	21.2

Volume of mould is 945 cc and $G = 2.67$. Determine the maximum dry density and optimum moisture content.

Answer

Given: Volume of mould = 945 cm³, Specific gravity, $G = 2.67$
To Find: Maximum dry density and Optimum moisture content.

Water Content (%)	Mass of Wet Soil (kg) (M)	$\rho_d = \left(\frac{1}{1+w} \right) \times \frac{M}{0.945}$ (gm/cc)
7.7	1.70	1.67
11.5	1.89	1.79
14.6	2.03	1.87
17.5	1.99	1.79
19.7	1.96	1.73
21.2	1.92	1.68

- 2. Curve between dry density and water content as shown in Fig. 3.7.1.

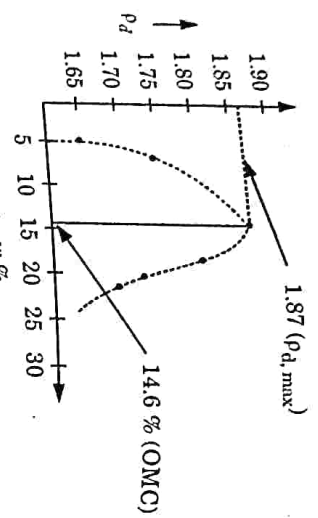

Fig. 3.7.1.

3. Maximum dry density, $\rho_{d, \max} = 1.87 \text{ gm/cc}$
4. Optimum moisture content = 14.6%

Que 3.8. The in situ void ratio of a granular soil deposit is 0.50.

The maximum and minimum void ratios of the soil were determined to be 0.75 and 0.35, $G = 2.67$. Determine the relative density and relative compaction of the deposit.

Answer

Given : In situ void ratio, $e_{\text{in situ}} = 0.50$

Maximum void ratio, $e_{\text{max}} = 0.75$

Minimum void ratio, $e_{\text{min}} = 0.35$, Specific gravity, $G = 2.67$

To Find : Relative density and Relative compaction.

1. Relative density = $\frac{e_{\text{max}} - e_{\text{in situ}}}{e_{\text{max}} - e_{\text{min}}}$
 $= \frac{0.75 - 0.50}{0.75 - 0.35} \times 100 = 62.5 \%$
2. Maximum dry unit weight of soil,
 $\gamma_{d(\text{max})} = \frac{G \gamma_w}{1 + e_{\text{min}}} = \frac{2.67 \times 9.8}{1 + 0.35} = 19.38 \text{ kN/m}^3$
3. Dry unit weight of soil in field,
 $\gamma_{d(\text{in situ})} = \frac{G \gamma_w}{1 + e_{\text{in situ}}} = \frac{2.67 \times 9.8}{1 + 0.50} = 17.44 \text{ kN/m}^3$
4. Relative compaction = $\frac{\gamma_{d(\text{in situ})}}{\gamma_{d(\text{max})}} \times 100 = \frac{17.44}{19.38} \times 100 = 89.9 \%$

PART-2

Consolidation, Primary and Secondary Consolidation, Terzaghi's One Dimensional Theory of Consolidation, Consolidation Test, Normal and Over Consolidation Soils, Over Consolidation Ratio, Determination of Coefficient of Consolidation.

Questions-Answers

Long Answer Type and Medium Answer Type Questions

Que 3.9. What do you mean by compressibility of soil ?

Answer

1. The property of the soil due to which decrease in volume occurs under compressive forces is known as the compressibility of soil.
2. When the soil mass is subjected to a compressive force, like all other materials, its volume decreases.
3. The compression of soils can occur due to one or more of the following reasons :
 - i. Compression of solid particles and water in the voids.
 - ii. Compression and expulsion of air in the voids.
 - iii. Expulsion of water in voids.
4. Compression of soil also takes place by expulsion of air from the voids under a vibratory load; such a compression is usually known as compaction.
5. In a saturated soil mass having its voids filled with incompressible water, decrease in volume or compression can take place when water is expelled out of the voids. Such a compression resulting from a long term static load and the consequent escape of pore water is termed as a consolidation.

Que 3.10. Explain consolidation. Also differentiate between consolidation and compaction.

OR

Write the difference between compaction and consolidation. The in-situ void ratio of a granular soil deposits is 0.50. The maximum and minimum soil ratio of the soil were determined to be 0.75 and 0.35, $G = 2.67$, also determine the relative density and relative compaction of the deposit.

OR

AKTU 2018-19, Marks 07

Compare between compaction and consolidation.

AKTU 2016-17, Marks 10

Answer

- A. Consolidation :**
1. The compression of a saturated soil under static pressure is known as consolidation.
 2. It is occurs due to expulsion of water from the voids.
 3. The soil particles shift from one position to other by rolling and sliding, thus they attain a closer packing.
 4. The decrease in soils volume occurs not due to compression of solids or water but due to shifting of soil particles as water escapes.
 5. Consolidation can occur due to one or more of the following factors :
 - i. Due to external static loads from the structures.
 - ii. Due to self-weight of the soil such as recently placed fills.
 - iii. Due to lowering of the ground water table.
 - iv. Due to desiccation.
- B. Difference between Consolidation and Compaction :**

S.No.	Consolidation	Compaction
1.	Consolidation is gradual reduction in volume under sustained static loading.	Compaction is reduction in volume under dynamic loads such as rolling, tamping, vibrating, etc.
2.	This process occurs itself in nature.	It is an artificial process.
3.	This is applicable to fully saturated soils.	It is applied to partially saturated soils.
4.	Reduction in volume occurs due to expulsion of water from the voids.	Reduction in volume occurs due to expulsion of air from the voids.
5.	It may take a lot of time, especially for clays it may take years.	It occurs instantaneously after the application of load.
6.		

3-12A (CE, Sem-5)

Soil Compaction & Consolidation

C. Numerical : Refer Q. 3.8, Page 3-9A, Unit-3.

Que 3.11. Write a short note on :

- A. Immediate settlement.
- B. Primary consolidation.
- C. Secondary consolidation.

Answer

- A. Immediate Settlement :**
1. Immediate or elastic settlement takes place during or immediately after the construction of the structure.
 2. It is also known as the distortion settlement as it is due to distortions (and not the volume change) within the foundation soil.
 3. Although the settlement is not truly elastic, it is computed using elastic theory, especially for cohesive soils.
- B. Primary Consolidation :**
1. After initial consolidation, further reduction in volume occurs due to the expulsion of water from the voids.
 2. When saturated soil is subjected to a pressure, initially all the pressure is taken up by the water as an excess pore water pressure.
 3. As water is almost incompressible as compared with solid particles. A hydraulic gradient develops and water starts flowing out and decrease in volume occurs.
 4. The decrease depends upon the permeability of soil and is therefore, time dependent.
 5. This reduction in volume is called primary consolidation.
- C. Secondary Consolidation :**
1. The reduction in volume continues at a very slow rate even after the excess hydrostatic pressure developed by the applied pressure is fully dissipated and the primary consolidation is complete.
 2. The additional reduction in volume is called secondary consolidation.
 3. It is attributed to the plastic readjustment of the solid particles and the adsorbed water to new stress system.

Que 3.12. Give the assumptions of the Terzaghi's theory for calculating the rate of 1-D consolidation and prove that :

$$\frac{\partial \bar{u}}{\partial t} = C_v \frac{\partial^2 \bar{u}}{\partial z^2}$$

AKTU 2017-18, Marks 10

Answer

- A. Assumptions :** Following are the assumptions made in Terzaghi's one dimensional consolidation theory :
1. The soil mass is homogeneous and fully saturated.
 2. The soil particles and water are incompressible.
 3. Darcy's law for flow of water through soil mass is applicable during consolidation.

4. Coefficient of permeability is constant during consolidation.
 5. Load is applied in one direction only and deformation occurs only in the direction of load applied.
 6. The deformation is entirely due to decrease in volume.
 7. The drainage of pore water occurs only in one direction.
 8. A boundary drainage face offers no resistance to flow of water from soil.
 9. During consolidation the change in thickness is continuous but final value of compression is related to initial thickness only.
- B. Derivation :**
- Fig. 3.12.1, shows a clay layer of thickness H , sandwiched between two layers of sand which serves as drainage faces.
1. When the layer is subjected to a pressure increment $\Delta\sigma$, excess hydrostatic pressure is set up in the clay layer.
 2. At the time t_0 , the instant of pressure application, whole of the consolidating pressure $\Delta\sigma$ is carried by the pore water so that the initial excess hydrostatic pressure \bar{u}_0 is equal to $\Delta\sigma$, and is represented by a straight line $\bar{u} = \Delta\sigma$ on the pressure distribution diagram.
 3. The distribution of excess hydrostatic pressure \bar{u} at any time t is indicated by the curve AFB , joining water levels, in the piezometric tubes, this curve is known as isochrone and number of such isochrones can be drawn at various time intervals t_1, t_2, t_3 etc.
 4. The slope of isochrones at any point at a given time indicates the rate of change of \bar{u} with depth.
 5. At any times t the hydraulic head $'h'$ corresponding to the excess hydrostatic pressure is given by,

$$h = \frac{\bar{u}}{\gamma_w} \quad \dots(3.12.1)$$
 6. Hence, the hydraulic gradient $'i'$ is given by,

$$i = \frac{\partial h}{\partial z} = \frac{1}{\gamma_w} \times \frac{\partial \bar{u}}{\partial z} \quad \dots(3.12.2)$$
 7. Thus, the rate of change of \bar{u} along the depth of the layer represents the hydraulic gradient.
 8. The velocity with which the excess pore water flows at the depth $'z'$ given by Darcy's law as :

$$v = ki = \frac{k}{\gamma_w} \times \frac{\partial \bar{u}}{\partial z} \quad \dots(3.12.3)$$
 9. The rate of change of velocity with depth is given by;

$$\frac{\partial v}{\partial z} = \frac{k}{\gamma_w} \frac{\partial^2 \bar{u}}{\partial z^2} \quad \dots(3.12.4)$$
 10. Consider a small soil element of size dx, dz , and width of dy perpendicular to the XZ plane.

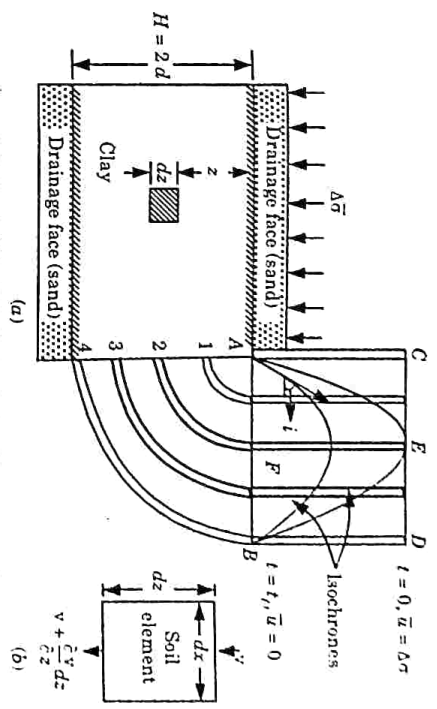

Fig. 3.12.1. One dimensional consolidation.

12. If v is the velocity of water at the entry into the soil elements, the velocity at the exit will be equal to $v + \frac{\partial v}{\partial z} dz$
13. The quantity of water entering the soil element per unit time = $v dx dy$
14. The quantity of water leaving the soil element per unit time

$$= \left(v + \frac{\partial v}{\partial z} dz \right) dx dy$$
15. Hence, the net quantity of water dq squeezed out of the soil element per unit time is given by,

$$dq = \frac{\partial v}{\partial z} dx dy dz \quad \dots(3.12.5)$$
16. The decrease in volume of soil is equal to the volume of water squeezed out. However, from

$$\Delta V = -m_v V_0 \Delta \bar{\sigma}$$

where,
 V_0 = Volume of soil element at time $t_0 = dx dy dz$
 m_v = Coefficient of volume change.
 $\Delta \bar{\sigma}$ = Increase in effective stress.
17. \therefore Change of volume of soil element per unit time is given as :

$$\Delta q = \frac{\partial(\Delta V)}{\partial t} = m_v dx dy dz \frac{\partial(\Delta \bar{\sigma})}{\partial t} \quad \dots(3.12.7)$$
18. Equating eq. (3.12.5) and (3.12.7), we get

$$\frac{\partial v}{\partial z} = -m_v \frac{\partial(\Delta \bar{\sigma})}{\partial t} \quad \dots(3.12.8)$$

$\Delta \bar{\sigma} = \Delta \bar{\sigma} + \bar{u}$, where $\Delta \bar{\sigma}$ is constant.

$$\frac{\partial(\Delta \bar{\sigma})}{\partial t} = - \frac{\partial \bar{u}}{\partial t} \quad \dots(3.12.9)$$

19. Hence, from eq. (3.12.8) and (3.12.9), we get

$$\frac{\partial v}{\partial z} = m_v \frac{\partial u}{\partial z}$$

20. Combining eq. (3.12.4) and (3.12.10), we get

$$\frac{\partial \bar{u}}{\partial t} = \frac{k}{\gamma_w m_v} \frac{\partial^2 \bar{u}}{\partial z^2}$$

where, $C_v = \frac{k}{\gamma_w m_v}$ = Coefficient of consolidation.

Que 3.13. Describe the objective and procedure of consolidation test in brief.

Answer

A. Object of Consolidation Test : To determine the compressibility characteristics of soil one dimensional consolidation (Oedometer) test is carried out. Objective of test :

1. To determine the amount of deformation.
2. To determine the rate of deformation

B. Procedure :

1. Sample is placed in the cutting ring in between two porous stone.
2. The loading beam is then brought into contact and dial gauge is set at zero.
3. When first load of 10 kN/m² is applied reading of dial gauge is taken at 1/4, 1/2, 1, 2, 4, 8, 16, 30, 60, 120, 240, 240, 1440 mins.
4. Now load is doubled and dial gauge reading is taken as in step 3. Load is doubled upto 640 kN/m².
5. Unloading is done by removing 3/4th load and reading is observed as earlier.

Que 3.14. Write a short note on :

- A. Normally consolidated soils and over consolidated soils.**
- B. Coefficient of compressibility and coefficient of volume change.**
- C. Compression index, swelling index and recompression index.**

Answer

1. **A. Normally Consolidated and Overconsolidated Soil :**
A normally consolidated soil is one which has not been subjected in past, to a pressure greater than the present existing pressure.
2. A soil is said to be overconsolidated if it has been subjected in the past to a pressure in excess of the present pressure.
3. Normally consolidated soils and overconsolidated soils are not the different types of soils but these only indicate the condition or state of soil in relation to the past and present pressures exerted on it.

4. The same soil may behave as normally consolidated soil in a certain pressure range and as overconsolidated soil in some other pressure range.

5. The liquidity index of normally consolidated clay is generally between 0.6 and 1.0, whereas that for overconsolidated clay is between 0 and 0.6.

B. Coefficient of Compressibility and Coefficient of Volume Change :

1. Coefficient of Compressibility :

The coefficient of compressibility (a_v) is defined as decrease in void ratio per unit increase in effective stress. It is equal to the slope of the $e - \bar{\sigma}$ curve at the point under consideration

$$a_v = \frac{-de}{d\bar{\sigma}} = \frac{-\Delta e}{\Delta \bar{\sigma}}$$

ii. As the effective stress increases, the void ratio decreases, and therefore, the ratio $de/d\bar{\sigma}$ is negative.

iii. The minus sign makes a_v positive. For convenience, the coefficient of compressibility a_v is reported as positive.

2. Coefficient of Volume Change : The coefficient of volume change (or the coefficient of volume compressibility) is defined as the volumetric strain per unit increase in effective stress. Thus

$$m_v = \frac{-\Delta V / V_0}{\Delta \bar{\sigma}} = a_v / (1 + e_0)$$

where, m_v = Coefficient of volume change.

V_0 = Initial volume.

ΔV = Change in volume.

$\Delta \bar{\sigma}$ = Change in effective stress.

C. Compression Index, Swelling Index and Recompression Index :

1. The compression index (C_c) is equal to the slope of the linear portion of the void ratio vs. $\log \bar{\sigma}$ plot. Thus,

$$C_c = \frac{-\Delta e}{\log_{10}(\bar{\sigma} / \Delta \sigma_0)}$$

2. The expansion index or swelling index (C_s) is the slope of void ratio vs. $\log \bar{\sigma}$ plot obtained during unloading.

$$C_s = \frac{\Delta e}{\log_{10} \left(\frac{\bar{\sigma} + \Delta \bar{\sigma}}{\bar{\sigma}} \right)}$$

3. Recompression index is the slope of the recompression curve obtained during reloading. It is expressed as,

$$C_r = \frac{-\Delta e}{\log_{10} \left(\frac{\bar{\sigma} + \Delta \bar{\sigma}}{\bar{\sigma}} \right)}$$

Que 3.15. Briefly differentiate between :

- A. Coefficient of consolidation and degree of consolidation.
- B. Laboratory consolidation curve and field consolidation relationship.

Answer

A. Difference between Coefficient of Consolidation and degree of Consolidation.

S.No.	Coefficient of Consolidation	Degree of Consolidation
1.	The coefficient of consolidation represents the combined effect of the coefficient permeability (k) and the coefficient of volume compressibility (m_v).	The degree of consolidation U_z represents the stage of consolidation at a certain location in the consolidating layer.
2.	It is expressed as : $T_v = \frac{C_v t}{d^2} = \left(\frac{k}{m_v \gamma_w} \right) \frac{t}{d^2}$	Degree of consolidation is given by $U_z = \frac{U_1 - U_2}{U_1}$
3.	It has units [$L^2 T^{-1}$] i.e., m^2/sec or m^2/day	It is unitless quantity.

B. Laboratory consolidation curve and field consolidation relationship :

S.No.	Laboratory Consolidation Curve	Field Consolidation Curve
1.	The consolidation curve measured represents the behavior of soil in the laboratory.	The consolidation curve measured represents the behavior of soil in the field.
2.	Soil nature and physical features are positively identified.	The nature of the tested soil is not directly identified by field tests.
3.	Higher costs generally associated with determining engineering properties of foundation soils using laboratory.	Determining engineering properties of foundation soils by means of field test is more economical and less time consuming.

Que 3.16. Explain methods for determining the coefficient of consolidation of a soil.

Answer

Following are the method for determining coefficient of consolidation of a soil :

A. **Logarithm-of-time Method :**

1. Plot the dial readings for sample deformation for a given load increment against time on semi log graph paper as shown in Fig. 3.16.1.
2. Plot two points, P and Q on the upper portion of the consolidation curve which correspond to time t_1 and t_2 , respectively. Note that $t_2 = 4t_1$.
3. The difference of dial readings between P and Q is equal to x . locate point R , which is at a distance x above point P .
4. Draw the horizontal line RS . The dial reading corresponding to this line is d_p , which corresponds to 0% consolidation.
5. Project the straight-line portions of the primary consolidation and the secondary consolidation to intersect at T , the dial reading corresponding to T is d_{100} i.e., 100% primary consolidation.
6. Determine the point V on the consolidation curve which corresponds to a dial reading of $(d_0 + d_{100})/2 = d_{50}$. The time corresponding to the point V is t_{50} i.e., time for 50% consolidation.
7. Determine C_v from the equation $T_v = C_v \times t/d^2$. The value of T_v for $U_{av} = 50\%$ is 0.197. So, $C_v = \frac{0.197 d^2}{t_{50}}$

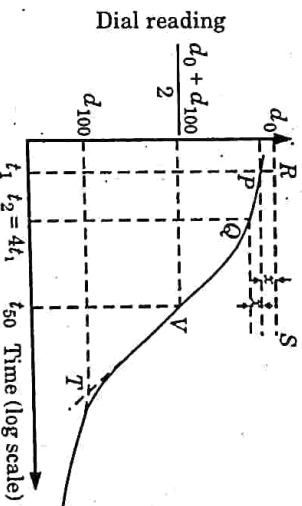

Fig. 3.16.1. Logarithm-of-time method for determination of C_v

B. **Square-root-of-time Method :**

1. Plot the dial reading and the corresponding square-root-of-time \sqrt{t} as shown in Fig. 3.16.2.
2. Draw the tangent PQ to the early portion of the plot.
3. Draw a line PR such that $OR = (1.15)(OQ)$.
4. The abscissa of the point S (i.e., the intersection of PR and the consolidation curve) will give $\sqrt{t_{90}}$ (i.e., the square-root-of-time for 90% consolidation).

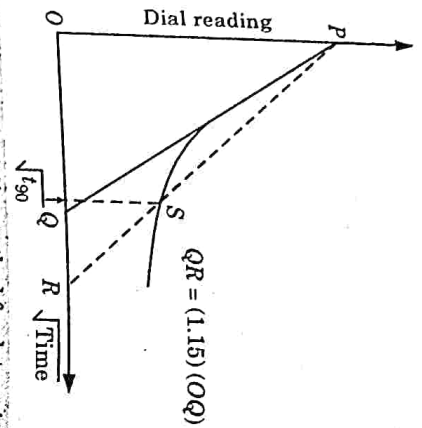

Fig. 3.16.2. Square-root-of-time method for determination of C_v .

5. The value of T_v for $U_{av} = 90\%$ is 0.848. So,

$$C_v = \frac{0.848 d^2}{t_{90}}$$

Que 3.17. Write a short note on :

- A. Contact pressure.
- B. Final settlement by void ratio.

Answer

A. Contact Pressure : The upward pressure due to soil on the underside of the footing is termed as contact pressure. It is of following types :

- 1. Contact Pressure on Saturated Clay for Flexible Footing :

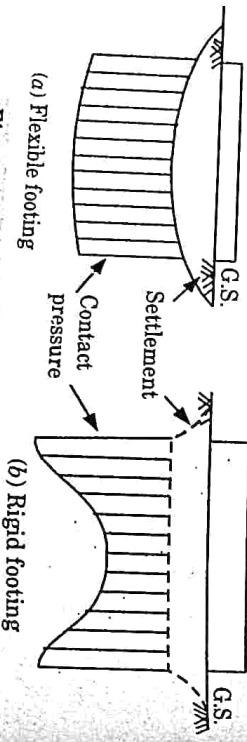

Fig. 3.17.1. Contact pressure on saturated clay.

- 1. Fig. 3.17.1 shows the qualitative contact pressure distribution under flexible and rigid footings resting on a saturated clay and subjected to a uniformly distributed load q .
- ii. When the footing is flexible, it deforms into the shape of a bowl, with the maximum deflection at the centre.
- iii. The contact pressure distribution is uniform.

2. Contact Pressure on Saturated Clay For Rigid Footing [Fig. 3.17.2(b)] :

- i. If the footing is rigid, the settlement is uniform.
 - ii. The contact pressure distribution is minimum at the centre and the maximum at the edges.
 - iii. The stresses at the edges in real soils cannot be infinite as theoretically determined for an elastic mass.
 - iv. In real soils, beyond a certain limiting value of stress, the plastic flow occurs and the pressure becomes finite.
3. Contact Pressure on Sand For Flexible Footing :
- Fig. 3.17.2 shows the qualitative contact pressure distribution under flexible and rigid footing resting on a sandy soil and subjected to a uniformly distributed load q .
- ii. In this case, the edges of the flexible footing undergo a large settlement than at the centre.
 - iii. The contact pressure is uniform.

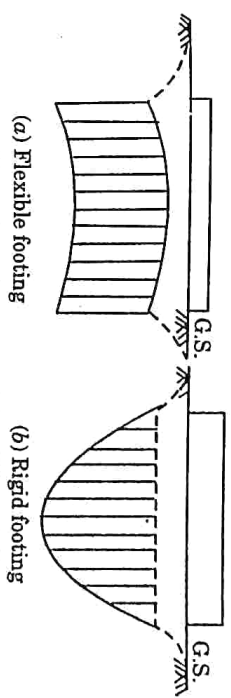

Fig. 3.17.2. Contact pressure on sand.

4. Contact Pressure on Sand For Rigid Footing [Fig. 3.17.2(b)] :

- i. If the footing is rigid, the settlement is uniform.
 - ii. The contact pressure increase from zero at the edges to a maximum at the centre.
 - iii. The soil, being unconfined at edges, has low modulus of elasticity. However, if the footing is embedded, there would be finite contact pressure at edges.
- B. Final Settlement by Void Ratio : The final settlement ΔH can also be computed from the following relationship :

$$\frac{\Delta H}{H} = \frac{e_1 - e_2}{1 + e_1} \quad \text{or} \quad \Delta H = \frac{e_1 - e_2}{1 + e_1} \times H$$

1. For Normally Consolidated Soils : Compression index for normally consolidated soil is constant. Hence substituting the value of $e_1 - e_2$ in terms of C_c

$$\Delta H = H \times \frac{C_c}{1 + e_1} \log_{10} \frac{\bar{\sigma}_2}{\bar{\sigma}_1}$$

where,

$$\bar{\sigma}_2 = \bar{\sigma}_1 + \Delta \bar{\sigma}$$

2 For Overconsolidated Soils :
 i Final settlement is small in case of preconsolidated soils as the re. compression index or the swelling index C_s is very small in comparison to C_c .

ii Now
$$e_1 - e_2 = C_s \log_{10} \frac{\bar{\sigma}_2}{\bar{\sigma}_1}$$

iii Settlement,
$$\Delta H = \frac{C_s}{1 + e_1} H \log_{10} \frac{\bar{\sigma}_2}{\bar{\sigma}_1}$$

iv. The above equation is applicable where $\bar{\sigma}_2$ is smaller than the pre-consolidation pressure $\bar{\sigma}_p$.

v. If the pre-consolidation/over consolidation $\bar{\sigma}_p$ is greater than $\bar{\sigma}_1$ but smaller than $\bar{\sigma}_2$, then final settlement is computed in two parts :

- a. Settlement due to pressure $\bar{\sigma}_1$ to $\bar{\sigma}_p$ using C_s , and
- b. Settlement due to pressure $\bar{\sigma}_p$ to $\bar{\sigma}_2$ using C_c .

vi. Thus,
$$\Delta H = \frac{C_s}{1 + e_1} H \log_{10} \frac{\bar{\sigma}_p}{\bar{\sigma}_1} + \frac{C_c}{1 + e_1} H \log_{10} \frac{\bar{\sigma}_2}{\bar{\sigma}_p}$$

Que 3.18. A soil sample 40 mm thick takes 40 minute to reach 40 % consolidation. Find the time taken for a clay layer 8 m thick to reach 80 % consolidation. Assume double drainage in both cases.

AKTU 2016-17, Marks 10

Answer

Given : Thickness of sample = 40 mm, Thickness of field layer = 8 m, Degree of field consolidation = 80 %
 Degree of sample consolidation, $U = 40 \%$, Time, $t = 40$ min
To Find : Time consumed in field consolidation.
 $= 40 \times 60 = 2400$ sec

A. For 40 % Consolidation :

- 1. Drainage path for double drainage, $d = \frac{40}{2} = 20$ mm
- 2. Time factor,

$$T_v = \frac{\pi}{4} \left[\frac{U}{100} \right]^2, \quad (\text{For } U < 60 \%)$$

$$= \frac{\pi}{4} \left(\frac{40}{100} \right)^2 = 0.1256$$

3. Coefficient of consolidation,

$$C_v = \frac{T_v d^2}{t}$$

$$C_v = \frac{0.1256 \times (20)^2}{2400} = 0.0209 \text{ mm}^2/\text{sec}$$

B. For 80 % Consolidation :

- 1. Drainage path for double drainage, $d = \frac{8000}{2} = 4000$ mm
- 2. Time factor, (For $U > 60 \%$), $T_v = 1.781 - 0.933 \log_{10} (100 - U \%)$
 $T_v = 1.781 - 0.933 \log_{10} (100 - 80) = 0.567$
- 3. We know that,

$$C_v = \frac{T_v d^2}{t}$$

$$0.0209 = \frac{0.567 \times (4000)^2}{t}$$

$$t = 434066985.6 \text{ sec}$$

$$t = 5023.923 \text{ days}$$

Que 3.19. A soil sample 20 mm thick takes 20 min. to reach 20 % consolidation. Find the time taken for a clay layer 6 m thick to reach 40 % consolidation. Assume double drainage in both cases.

AKTU 2015-16, Marks 10

Answer

Given : Thickness of sample = 20 mm, Degree of consolidation, $U = 20 \%$, Time, $t = 20$ min, Field degree of consolidation, $U = 40 \%$
 Thickness of field clay layer = 6 m
To Find : Time taken for consolidation.

1. For Soil Sample :

- i. Drainage path for double drainage, $d = \frac{20}{2} = 10$ mm
 - ii. Time, $t = 20 \times 60 = 1200$ sec
 - iii. Time factor for $U < 60 \%$ is given by,
- $$T_v = \frac{\pi}{4} \left[\frac{U}{100} \right]^2 = \frac{\pi}{4} \left[\frac{20}{100} \right]^2 = 0.0314$$
- iv. Also time factor is given by, $T_v = C_v \frac{t}{d^2}$

$$\text{Coefficient of consolidation } C_v = \frac{T_v d^2}{t} = \frac{0.0314 \times 10^2}{1200} = 2.62 \times 10^{-3} \text{ mm}^2/\text{sec}$$

2 For Field Clay Layer:

i Drainage path for double drainage, $d = \frac{6000}{2} = 3000 \text{ mm}$

ii Time factor for $U < 60\%$, $T_v = \frac{\pi}{4} \left(\frac{U}{100} \right)^2 = \frac{\pi}{4} \left(\frac{40}{100} \right)^2 = 0.126$

iii We know that, $C_v = \frac{T_v d^2}{t}$

Time taken by clay layer for 40% consolidation,

$$t = \frac{0.126 \times 3000^2}{2.62 \times 10^{-3}} = 432824427.5 \text{ sec} = 5009.54 \text{ days}$$

Que 3.20. A saturated clay layer of 5 m thickness takes 1.5 years for 50% primary consolidation, when drained on both sides. Its coefficient of volume change m_v is $1.5 \times 10^{-3} \text{ m}^2/\text{kN}$. Determine the coefficient of consolidation (in m^2/yr) and the coefficient of permeability (in m/yr).

AKTU 2019-20, Marks 07

Answer

Given : Thickness of clay layer = 5 m, Percentage of consolidation, $U = 50\%$, Time, $t = 1.5 \text{ yr}$, Coefficient of volume change, $m_v = 1.5 \times 10^{-3} \text{ m}^2/\text{kN}$

To Find : Coefficient of consolidation and coefficient of permeability.

1. Time factor for $U < 60\%$ is given by,

$$T_v = \frac{\pi}{4} \left(\frac{U}{100} \right)^2$$

$$T_v = \frac{\pi}{4} \left(\frac{50}{100} \right)^2 = 0.19635$$

2. Coefficient of consolidation is given by,

$$C_v = \frac{T_v d^2}{t}$$

$$C_v = \frac{0.19635 \times 2.5^2}{1.5} = 0.818 \text{ m}^2/\text{yr}$$

$$\left[\because d = \frac{5}{2} = 2.5 \text{ m} \right]$$

3-21 A (CE-Sem-5)

Soil Compaction & Consolidation

3. Coefficient of permeability is given by, $k = C_v m_v \gamma_w = 0.818 \times 1.5 \times 10^{-3} \times 10 = 0.01227 \text{ m}/\text{yr}$

Que 3.21. In the laboratory a 2 cm thick soil sample takes 25 minutes to reach 30% degree of consolidation. Find the time taken for a 5 m thick clay layer in field to reach 40% consolidation. Assume double drainage both cases.

AKTU 2018-19, Marks 07

Answer

Given : Thickness of sample = 20 mm, Time, $t = 25 \text{ min}$, Degree of consolidation, $U = 30\%$, Thickness of clay layer = 5 m, Field degree of consolidation, $U = 40\%$

To Find : Time taken for reach 40% consolidation.

1. For Soil Sample :

i. Drainage path for double drainage, $d = 20/2 = 10 \text{ mm}$

ii. Time, $t = 25 \times 60 = 1500 \text{ sec}$

iii. Time factor is given by, $T_v = \frac{\pi}{4} \left[\frac{U}{100} \right]^2 = \frac{\pi}{4} \left[\frac{30}{100} \right]^2 = 0.07$

iv. Time factor, $T_v = C_v \frac{t}{d^2}$
Coefficient of consolidation,

$$C_v = \frac{T_v d^2}{t} = 0.07 \times \frac{10^2}{1500} = 4.67 \times 10^{-3} \text{ mm}^2/\text{sec}$$

2. For Field Clay Layer :

i. For double drainage, drainage path, $d = \frac{5000}{2} = 2500 \text{ mm}$

ii. Time factor, $T_v = \frac{\pi}{4} \left[\frac{U}{100} \right]^2 = \frac{\pi}{4} \left[\frac{40}{100} \right]^2 = 0.126$

iii. Time taken, $t = \frac{T_v d^2}{C_v} = \frac{0.126 \times (2500)^2}{4.67 \times 10^{-3}}$

$$t = 168629350.3 \text{ sec}$$

$$t = 1951.73 \text{ days}$$

Que 3.22. During a laboratory consolidation test, the time and dial gauge readings obtained from an increase of pressure on the specimen from 50 kN/m^2 to 100 kN/m^2 are given here :

Time (Minute)	0	0.1	0.25	0.5	1.0	2.0	4.0	8.0
Dial Gauge Reading (cm $\times 10^{-4}$)	3975	4082	4102	4128	4166	4224	4298	4420

Time (Minute)	16.0	30.0	60.0	120.0	240.0	480.0	960.0	1440.0
Dial Gauge Reading (cm x 10 ⁻⁴)	4572	4737	4923	5080	5207	5283	5334	5364

Using the logarithm of time method, determine C_v . The average height of the specimen during consolidation was 2.24 cm, and it was drained at the top and bottom.

Answer

Given : Height of specimen = 2.24 cm, Increase in pressure = 50 kN/m²
 To Find : C_v

- The semi-logarithmic plot of dial reading versus time is shown in Fig. 3.22.1.

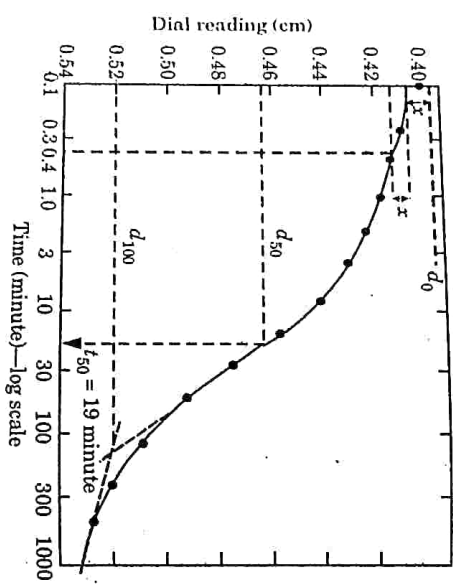

Fig. 3.22.1.

- For this, $t_1 = 0.1$ minute, $t_2 = 0.4$ minute to determine d_0 .
 $d_{100} = 0.52$
 $d_0 = 0.416$
 $d_{50} = \frac{d_0 + d_{100}}{2} = \frac{0.416 + 0.52}{2} = 0.468$
- t_{50} is calculated by corresponding to d_{50} , $t_{50} \approx 19$ minute (from curve)
- We know that,

$$C_v = \frac{0.197H^2}{t_{50}} = \frac{0.197 \left(\frac{2.24}{2}\right)^2}{19} = 0.013 \text{ cm}^2/\text{minute} = 2.17 \times 10^{-4} \text{ cm}^2/\text{sec}$$

Que 3.23.

Representative samples of a layer of silty clay, 5 m thick, were tested in a consolidometer and the following results were obtained : Initial void ratio = 0.90, Preconsolidation stress = 120 kN/m², Recompression index = 0.03 and Compression index = 0.27. Estimate the consolidation settlement if the present average overburden stress of the layer is 70 kN/m² and the increase in average stress in the layer is 80 kN/m².

Answer

Given : Thickness of layer of silty clay, $H_0 = 5$ m, Initial void ratio, $e_0 = 0.9$, Preconsolidation stress, $\bar{\sigma}_c = 120$ kN/m², Recompression index, $C_r = 0.03$, Compression index, $C_c = 0.27$, Average overburden stress, $\bar{\sigma}_o = 70$ kN/m², Increase in average stress = 80 kN/m²
 To Find : Consolidation settlement.

- The increased stress, $(\bar{\sigma}_o + \Delta\bar{\sigma}) = 70 + 80 = 150$ kN/m². This is greater than $\bar{\sigma}_c$ (= 120 kN/m²).
- Settlement is given by,

$$S_c = C_r \frac{H_0}{1 + e_0} \log \frac{\bar{\sigma}_c}{\bar{\sigma}_o} + C_c \frac{H_0}{1 + e_0} \log \frac{\bar{\sigma}_o + \Delta\bar{\sigma}}{\bar{\sigma}_o}$$

$$S_c = 0.03 \times \frac{5 \times 10^3}{1 + 0.90} \log \frac{120}{70} + 0.27 \times \frac{5 \times 10^3}{1 + 0.90} \log \frac{150}{120}$$

Consolidation settlement, $S_c = 18.48 + 68.85 = 87.33$ mm

Que 3.24.

A clay soil, tested in a consolidometer showed a decrease in void ratio from 1.20 to 1.10 when the pressure was increased from 0.25 to 0.50 kgf/cm². Calculate the coefficient of compressibility (a_v) and the coefficient of volume compressibility (m_v). If the coefficient of consolidation (C_v) determined in the test for the given stress increment was 10 m²/year, calculate the permeability in cm/sec. If the sample tested at the site was taken from a clay layer 3.0 m in thickness, determine the consolidation settlement resulting from the given stress increment.

Answer

Given : Decrease in void ratio = 1.20 to 1.10
 Increased in pressure = 0.25 to 0.50 kgf/cm²; $C_v = 10$ m²/year
 Thickness of clay layer = 3 m.
 To Find : Coefficient of compressibility, Coefficient of volume compressibility, Coefficient of permeability, Consolidation settlement.

- Change in void ratio, $\Delta e = e_0 - e = 1.20 - 1.10 = 0.10$

- Increase in pressure, $\Delta \bar{\sigma} = 0.50 - 0.25 = 0.25 \text{ kgf/cm}^2$
- Coefficient of compressibility,
$$a_v = \frac{\Delta e}{\Delta \bar{\sigma}} = \frac{0.10}{0.25} = 0.4 \text{ cm}^2/\text{kgf}$$
- Coefficient of volume compressibility,
$$m_v = \frac{a_v}{1+e_0} = \frac{0.4}{1+1.20} = 0.18 \text{ cm}^2/\text{kgf}$$

- Coefficient of consolidation,
$$C_v = 10 \text{ m}^2/\text{year} = \frac{10 \times 10^4}{365 \times 24 \times 60 \times 60} \text{ cm}^2/\text{sec}$$

 $= 3.17 \times 10^{-3} \text{ cm}^2/\text{sec}$

- Coefficient of permeability, $k = C_v m_v \gamma_w = 3.17 \times 10^{-3} \times 0.18 \times 1000 \times 10^{-4}$
 $= 5.7 \times 10^{-5} \text{ cm/sec}$

- Consolidation settlement,
$$S_c = H_0 \frac{\Delta e}{1+e_0} = \frac{3.0 \times 0.10}{1+1.20} = 0.136 \text{ m}$$

Que 3.25. A normally consolidated clay layer of 10 m thickness has a unit weight of 20 kN/m³ and specific gravity of 2.72. The liquid limit of the clay is 58%. A structure constructed on the clay increases the overburden pressure by 10%. Estimate the consolidation settlement.

AKTU 2019-20, Marks 07

Answer

Given : Thickness of clay layer, $H = 10 \text{ m}$, Unit weight of clay, $\gamma = 20 \text{ kN/m}^3$, Specific gravity, $G = 2.72$, Liquid limit, $w_L = 58\%$, Increase in overburden pressure = 10%.

To Find : Consolidation settlement.

- Void ratio for saturated soil, $e = wG = 0.58 \times 2.72 = 1.5776$
- Compression index for remoulded soil, $C_c = 0.007 (w_L - 7)$
 $= 0.007 (58 - 7) = 0.357$
- Stress at the centre of the clay layer, $\bar{\sigma}_0 = \gamma D = 20 \times 5 = 100 \text{ kN/m}^2$
- Increases in stress, $\Delta \bar{\sigma} = 10\%$ of $\bar{\sigma}_0 = 100 \times 0.1 = 10 \text{ kN/m}^2$
- Consolidation settlement is given by,

$$S_c = \frac{C_c H}{1+e_0} \log \frac{\bar{\sigma}_0 + \Delta \bar{\sigma}}{\bar{\sigma}_0}$$

$$= \frac{0.357 \times 10}{1+1.5776} \times \log \left(\frac{100+10}{100} \right) = 0.05733 \text{ m}$$

$$= 57.33 \text{ mm}$$

Que 3.26. In a consolidation test, the void ratio of the specimen which was 1.068 under the effective pressure of 214 kN/m², changed to 0.994 when the pressure was increased to 429 kN/m². Calculate the coefficient of permeability, compression index. Also find the settlement of foundation resting on above type of clay, if thickness of layer is 8 m and the increase in pressure is 10 kN/m².

AKTU 2018-19, Marks 07

Answer

Given : Initial void ratio = 1.068, Final void ratio = 0.994,
Initial effective pressure = 214 kN/m²,
Final effective pressure = 429 kN/m²,
Thickness of clay layer = 8 m, Increase in pressure = 10 kN/m²

To Find : Coefficient of permeability, Compression index and Settlement.

- Coefficient of Permeability:
- Coefficient of compressibility,

$$a_v = \frac{\Delta e}{\Delta \bar{\sigma}} = \frac{1.068 - 0.994}{429 - 214} = 3.44 \times 10^{-4} \text{ m}^2/\text{kN}$$

- Coefficient of volume compressibility,

$$m_v = \frac{\Delta e}{\Delta \bar{\sigma} (1+e_0)} = \frac{3.44 \times 10^{-4}}{1+1.068}$$

$$= 1.664 \times 10^{-4} \text{ m}^2/\text{kN}$$

- Coefficient of permeability, $k = c_v m_v \gamma_w$
Assume, $c_v = 4.8 \times 10^{-6} \text{ m/min}$
 $\gamma_w = 9.8 \text{ kN/m}^3$

$$k = 4.8 \times 10^{-6} \times 1.664 \times 10^{-4} \times 9.8$$

$$= 78.275 \times 10^{-8} \text{ m/min}$$

- Compression index,

$$C_c = \frac{\Delta e}{\log_{10} (\bar{\sigma} / \sigma_0)} = \frac{1.068 - 0.994}{\log_{10} \left(\frac{429}{214} \right)}$$

$$C_c = 0.245$$

- Settlement,

$$S = \frac{C_c}{1+e_0} H_0 \log_{10} \left(\frac{\bar{\sigma}_0 + \Delta \bar{\sigma}}{\bar{\sigma}_0} \right)$$

$$= \frac{0.245 \times 8}{1+1.068} \log_{10} \left(\frac{214+10}{214} \right) = 0.0188 \text{ m}$$

$$S = 18.8 \text{ mm}$$

VERY IMPORTANT QUESTIONS

Following questions are very important. These questions may be asked in your **SESSIONALS** as well as **UNIVERSITY EXAMINATION**.

Q. 1. What is compaction ? What kind of improvement of the engineering properties of a soil mass can be brought about through compaction ?
 Ans. Refer Q. 3.1, Unit-3.

Q. 2. What are various types of field compacting equipment? Which type of rollers are suited for clayey and gravel soils? Also give specifications of such rollers.
 Ans. Refer Q. 3.3, Unit-3.

Q. 3. How will you perform the Proctor's needle test in a site? controlling the degree of compaction ?
 Ans. Refer Q. 3.4, Unit-3.

Q. 4. Explain consolidation. Also differentiate between consolidation and compaction.
 Ans. Refer Q. 3.10, Unit-3.

Q. 5. Write a short note on :
 i. Immediate settlement.
 ii. Primary consolidation.
 iii. Secondary consolidation.
 Ans. Refer Q. 3.11, Unit-3.

Q. 6. Briefly differentiate between :
 A. Coefficient of consolidation and degree of consolidation
 B. Laboratory consolidation curve and field consolidation relationship.
 Ans. Refer Q. 3.15, Unit-3.

Q. 7. A soil sample 40 mm thick takes 40 minutes to reach 40% consolidation. Find the time taken for a clay layer 8m thick to reach 80 % consolidation. Assume double drainage in both cases.
 Ans. Refer Q. 3.18, Unit-3.

Q. 8. A saturated clay layer of 5 m thickness takes 1.5 years to reach 50 % primary consolidation, when drained on both sides.

Its coefficient of volume change m_v is $1.5 \times 10^{-3} \text{ m}^2/\text{kN}$. Determine the coefficient of consolidation (in m^2/yr) and the coefficient of permeability (in m/yr).
 Ans. Refer Q. 3.20, Unit-3.

Q. 9. In the laboratory a 2 cm thick soil sample takes 25 minutes to reach 30 % degree of consolidation. Find the time taken for a 5 m thick clay layer in field to reach 40% consolidation. Assume double drainage both cases.
 Ans. Refer Q. 3.21, Unit-3.

Q. 10. A normally consolidated clay layer of 10 m thickness has a unit weight of $20 \text{ kN}/\text{m}^3$ and specific gravity of 2.72. The liquid limit of the clay is 58 %. A structure constructed on the clay increases the overburden pressure by 10%. Estimate the consolidation settlement.
 Ans. Refer Q. 3.25, Unit-3.



4 UNIT

Stress Distribution in Soil and Shear Strength

CONTENTS

<p>Part-1 : Elastic Constants of Soils 4-2A to 4-9A and their Determination, Boussinesq Equation for Vertical Stress, The Westergaard Equation</p> <p>Part-2 : Stress Distribution Under 4-9A to 4-17A Loaded Areas, Concept of Pressure Bulb, Contact Pressure</p> <p>Part-3 : Shear Strength : 4-17A to 4-33A Mohr Coulomb Failure Criterion, Shear Strength Parameters and Determination, Direct and Tri-axial Shear Test, Unconfined Compression Test, Pore Pressure, Skempton's Pore Pressure Coefficients, Soil Liquefaction</p>	<p>4-2A to 4-9A</p> <p>4-9A to 4-17A</p> <p>4-17A to 4-33A</p>
-----------------------------------------------------------------------------------------------------------------------------------------------------------------------------------------------------------------------------------------------------------------------------------------------------------------------------------------------------------------------------------------------------------------------------------------------------------------------------------------------------------------------------------------------------------------------------------------------------------------------------------------------	----------------------------------------------------------------

4-2 A (CE-Sem-5)

Stress Distribution in Soil & Shear Strength

PART-1

Elastic Constants of Soils and their Determination, Boussinesq Equation for Vertical Stress, the Westergaard Equation.

Questions-Answers

Long Answer Type and Medium Answer Type Questions

Que 4.1. Write short notes on :

- A. Boussinesq's analysis.
 - B. Westergaard's analysis.
- And also, write comparison between these two analyses.

Answer

A. Boussinesq's Analysis :

1. Stress at any point 'P' in the soil mass due to point load 'Q' applied over its surface at point 'O' can be computed using Boussinesq theory.
2. **Assumptions :** Following are the assumptions made in Boussinesq theory :
 - i. Soil is homogeneous, semi-infinite, elastic and isotropic.
 - ii. Hook's law is assumed to be valid in this theory.
 - iii. Self weight of soil is ignored.
 - iv. Soil is initially unstressed.
 - v. No change in the volume of soil takes place due to application of load.
 - vi. Distribution of the stresses is symmetrical about vertical axis.
 - vii. The surface of the soil is free from shear stress and it is subjected to only point load.

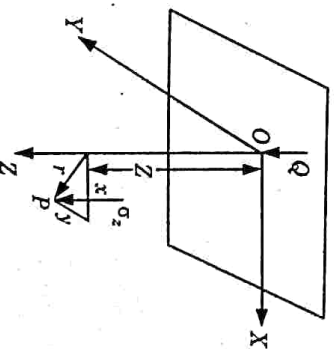

Fig. 4.1.1. Vertical stress due to point load.

3. Vertical stress, $\sigma_z = I_B \frac{Q}{Z^2}$

Geotechnical Engineering
 \$I_B\$ = Boussinesq's influence factor.

where,

$$I_B = \frac{3}{2\pi} \left[\frac{1}{1 + \left(\frac{r}{Z}\right)^2} \right]^{5/2}$$

\$Z\$ = Depth of point below surface of soil mass.
 \$r\$ = Radial distance of point \$P\$ from axis of load.

\$\Rightarrow\$

$$\sigma_z = \frac{3Q}{2\pi Z^2} \left[\frac{1}{1 + \left(\frac{r}{Z}\right)^2} \right]^{5/2}$$

4. Boussinesq's equation for shear stress at point \$P\$ due to point load \$Q\$ acting on the surface,

$$\tau_{rz} = \sigma_z \frac{r}{Z} = I_B \frac{Q}{Z^3} \frac{r}{Z}$$

$$\tau_{rz} = I_B \frac{Qr}{Z^3}$$

B. Westergaard's Analysis :

1. Assumptions : Following are the assumptions made in Westergaard's theory :

- i. Soil is homogenous, elastic, semi-infinite and non-isotropic.
- ii. Medium is assumed to be laterally reinforced with numerous closely spaced sheets of negligible thickness.
- iii. In this theory medium is assumed to be horizontally rigid but vertically elastic.

2. Vertical stress is given by, \$\sigma_z = I_w \frac{Q}{Z^2}\$

\$I_w\$ = Westergaard's influence factor

$$I_w = \frac{1}{\pi} \left[\frac{1}{1 + 2\left(\frac{r}{Z}\right)^2} \right]^{3/2}$$

\$\Rightarrow\$

$$\sigma_z = \frac{1}{\pi} \left[\frac{1}{1 + 2\left(\frac{r}{Z}\right)^2} \right]^{3/2} \frac{Q}{Z^2}$$

C. Comparisons between Boussinesq's and Westergaard's Theory

For any value of \$\frac{r}{Z}\$, \$\sigma_{zB} = \sigma_{zW}\$

$$I_B \frac{Q}{Z^2} = I_w \frac{Q}{Z^2}$$

$$I_B = I_w$$

$$\frac{3}{2\pi} \left[\frac{1}{1 + \left(\frac{r}{Z}\right)^2} \right]^{5/2} = \frac{1}{\pi} \left[\frac{1}{1 + 2\left(\frac{r}{Z}\right)^2} \right]^{3/2}$$

$$\frac{r}{Z} = 1.52$$

- 1. The effect of Westergaard's assumption is that the concentration of stress directly under the load is less than that given by Boussinesq but exceeds it at some distance from the centre.
 Thus at \$r/Z = 0\$, Westergaard's value is 67% of Boussinesq's value. at \$r/Z = 1.5\$, both are equal but at \$r/Z > 1.5\$, Westergaard's stresses are greater.
- 2. A concentrated load of 30 kN acts on the surface of a

Que 4.2. homogeneous soil mass of large extent. Find the stress intensity at a depth of 8 m and (i) directly under the load; (ii) at a horizontal distance of 6 m.

Answer

Given : \$Q = 30\$ kN, \$Z = 8\$ m
 To Find : The stress intensity :

- i. Directly under the load.
- ii. At a horizontal distance of 6 m.

i. Directly under the load, \$r = 0, Z = 8\$ m

$$\sigma_z = \frac{Q}{Z^2} \frac{3}{2\pi} \left[\frac{1}{1 + (r/Z)^2} \right]^{5/2}$$

$$= \frac{30}{8^2} \frac{3}{2\pi} \left[\frac{1}{1 + 0} \right]^{5/2} = 0.224 \text{ kN/m}^2$$

ii. At a horizontal distance of 6 m, \$r = 6\$ m, \$Z = 8\$ m

$$\frac{r}{Z} = \frac{6}{8} = 0.75$$

$$\sigma_z = \frac{30}{8^2} \times \frac{3}{2\pi} \left[\frac{1}{1 + (0.75)^2} \right]^{5/2}$$

$$= 0.0733 \text{ kN/m}^2$$

Que 4.3. An elevated structure with a total weight of 10,000 kN is supported on a tower with 4 legs. The legs rest on piers located at the corners of a square 6 m on a side. What is the vertical stress increment due to this loading at a point 7 m beneath the centre of the structure ?

OR

State the assumptions implied in the use of the Boussinesq's theory to determine the vertical stress in a soil due to a point load and discuss their validity. An elevated structure with a total weight of 10,000 kN is supported on a tower with 4 legs. The legs rest on piers located at the corners of a square 6 m on a side. What is the vertical stress increment due to this loading at a point 7 m beneath the centre of the structure?

Answer

A. Assumptions of Boussinesq's Theory: Refer Q. 4.1, Page 4-2A, Unit-4

B. Numerical:

Given: Total weight of structure = 10,000 kN, Depth of point, $Z = 7$ m
Side of square, $a = 6$ m

To Find: Vertical stress at point 7 m beneath the centre of the structure

1. Radial distance of point, $r = \sqrt{3^2 + 3^2} = \sqrt{18} = 4.24$ m

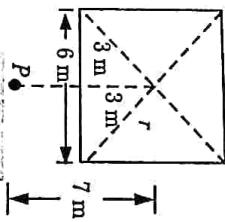

Fig. 4.3.1.

2. The total load is distributed in 4 equal parts the load carried by one

$$\text{leg} = \frac{10,000}{4} = 2500 \text{ kN}$$

3. The vertical stress at point P due to one leg,

$$\begin{aligned} \sigma_{z1} &= \frac{3Q}{2\pi Z^2} \left[\frac{1}{1 + \left(\frac{r}{Z}\right)^2} \right]^{5/2} \\ &= \frac{3 \times 2500}{2\pi \times 7^2} \left[\frac{1}{1 + \left(\frac{4.24}{7}\right)^2} \right]^{5/2} = 11.152 \text{ kN/m}^2 \end{aligned}$$

5. The total vertical stress due to all four legs of structure

$$\begin{aligned} \sigma &= 4 \times \sigma_{z1} = 4 \times 11.152 \\ \sigma &= 44.6 \text{ kN/m}^2 \end{aligned}$$

Que 4.4. A rectangular area 2 m x 4 m carries a uniform load of 8 t/m^2 at the ground surface. Find the vertical pressure at 5 m below the centre and corner of the loaded area.

AKTU 2018-19, Marks 07

Answer

Given: Size of rectangular = 2 m x 4 m, Load = 8 t/m^2 .

To Find: Vertical pressure at 5 m below the centre and corner.

1. Vertical Pressure below the Centre of Rectangular Area:

- i. The rectangular area divided into small rectangle is shown in Fig. 4.4.1.

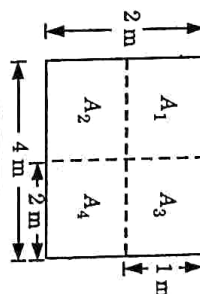

Fig. 4.4.1.

$$m = \frac{L}{Z} = \frac{2}{5} = 0.4$$

$$n = \frac{B}{Z} = \frac{1}{5} = 0.2$$

- ii. $\sigma_z = I_N q$

- v. For the centre of rectangular area, all the small rectangle are equal, so, vertical pressure,

$$\begin{aligned} \sigma_z &= 4qI_N \\ I_N &= \frac{1}{4\pi} \left[\frac{2mn(m^2 + n^2 + 1)^{1/2}}{m^2 + n^2 + 1} \times \frac{m^2 + n^2 + 2}{m^2 + n^2 + 1} + \tan^{-1} \frac{2mn(m^2 + n^2 + 1)^{1/2}}{m^2 + n^2 + 1 - m^2 n^2} \right] \dots (4.4.1) \end{aligned}$$

$$\begin{aligned} &= \frac{1}{4\pi} \left[\frac{2 \times 0.4 \times 0.2(0.4^2 + 0.2^2 + 1)^{1/2}}{0.4^2 + 0.2^2 + 1} \times \frac{0.4^2 + 0.2^2 + 2}{0.4^2 + 0.2^2 + 1} + \tan^{-1} \frac{2 \times 0.4 \times 0.2(0.4^2 + 0.2^2 + 1)^{1/2}}{0.4^2 + 0.2^2 + 1 - 0.4^2 \times 0.2^2} \right] \end{aligned}$$

$$= 0.0328 = 4 \times 8 \times 0.0328 = 1.0496 \text{ t/m}^2$$

2. Vertical Pressure at 5 m below the Corner:

- i. $m = \frac{L}{Z} = \frac{4}{5} = 0.8$

Geotechnical Engineering

$$n = \frac{B-2}{Z} = 0.4$$

ii. Similarly, value of m and n put in eq. (4.4.1) and calculate,

$$I_N = 0.0931$$

$$\sigma_z = q/I_N = 8 \times 0.0931 = 0.7448 \text{ kN/m}^2$$

iv. A concentrated load 10 kN acts on the surface of a soil

Que 4.5. Using Boussinesq analysis, find the vertical stress at points

mass. Using Boussinesq analysis, find the vertical stress at points (i) 3 m below the surface on the axis of loading, and (ii) at radial distance of 2 m from axis of loading and at depth of 3 m.

AKTU 2015-16, Marks 10

Answer

Given : Concentrated load, $Q = 10 \text{ kN}$, Depth of point, $Z = 3 \text{ m}$

Radial distance of point, $r = 0$

To Find : Vertical stresses.

1. Using Boussinesq equation :

Vertical stress at point 3 m below the surface,

$$\sigma_z = \frac{3Q}{2\pi Z^2} \left[\frac{1}{1 + \left(\frac{r}{Z}\right)^2} \right]^{5/2}$$

$$= \frac{3 \times 10}{2\pi \times 3^2} \times \left[\frac{1}{1 + \left(\frac{0}{3}\right)^2} \right]^{5/2}$$

$$\sigma_z = 0.53 \text{ kN/m}^2$$

2. Stress at radial distance of 2 m from axis of loading and at depth of 3 m is given by :

$$\sigma_z = \frac{3Q}{2\pi Z^2} \left[\frac{1}{1 + \left(\frac{r}{Z}\right)^2} \right]^{5/2}$$

$$= \frac{3 \times 10}{2\pi \times 3^2} \left[\frac{1}{1 + \left(\frac{2}{3}\right)^2} \right]^{5/2}$$

$$\sigma_z = 0.21 \text{ kN/m}^2$$

Que 4.6.

For a sedimentary soil deposit, which solution is more appropriate Boussinesq's or Westergaard's. Why ? State the assumptions involved in the Westergaard's theory. A concentrated load of 40 kN acts on the surface of a soil. Determine the vertical

stress increment at points directly beneath the load upto a depth of 10 m and draw a plot for the vertical stress variation upto depth of 10 m.

AKTU 2017-18, Marks 10

Answer

Reason for Appropriate Solution :

- Boussinesq's solution assumes that the deposit is isotropic. Actual sedimentary deposits are generally anisotropic.
 - There are generally thin layers of sand embedded in homogeneous clay strata.
 - Westergaard's solution assumes that there are thin sheets of rigid materials sandwiched in a homogeneous soil mass.
 - These thin sheets are closely spaced and are of infinite rigidity and are, therefore, incompressible.
 - These permit only downward displacement of the soil mass as a whole without any lateral displacement.
 - Therefore, Westergaard's solution represents more closely the actual sedimentary deposits.
- B. Westergaard's Theory Assumptions : Refer Q. 4.1, Page 4-2A, Unit-4.

C. Numerical :

Given : Vertical load, $Q = 40 \text{ kN}$, Depth, $Z = 10 \text{ m}$

To Find : Vertical stress variation upto depth 10 m.

1. Vertical stress is given by,

$$\sigma_z = \frac{3Q}{2\pi Z^2} \left[\frac{1}{1 + \left(\frac{r}{Z}\right)^2} \right]^{5/2}$$

2. Radial distance, $r = 0$

$$\sigma_z = \frac{3Q}{2\pi} \times \frac{1}{Z^2} \times \frac{1}{2 \times \pi} \times \frac{1}{Z^2} = \frac{19.10}{Z^2}$$

3. Vertical stress,

$$Z = 1, \quad \sigma_z = \frac{19.10}{1} = 19.10 \text{ kN/m}^2$$

$$Z = 2, \quad \sigma_z = \frac{19.10}{4} = 4.77 \text{ kN/m}^2$$

$$Z = 3, \quad \sigma_z = \frac{19.10}{9} = 2.12 \text{ kN/m}^2$$

$$Z = 4, \quad \sigma_z = \frac{19.10}{16} = 1.194 \text{ kN/m}^2$$

$$Z = 5, \quad \sigma_z = \frac{19.10}{25} = 0.764 \text{ kN/m}^2$$

$$Z = 6, \quad \sigma_z = \frac{19.10}{36} = 0.53 \text{ kN/m}^2$$

$$Z = 7, \quad \sigma_z = \frac{19.10}{49} = 0.39 \text{ kN/m}^2$$

$$Z = 8, \quad \sigma_z = \frac{19.10}{64} = 0.298 \text{ kN/m}^2$$

$$Z = 9, \quad \sigma_z = \frac{19.10}{81} = 0.236 \text{ kN/m}^2$$

$$Z = 10, \quad \sigma_z = \frac{19.10}{100} = 0.191 \text{ kN/m}^2$$

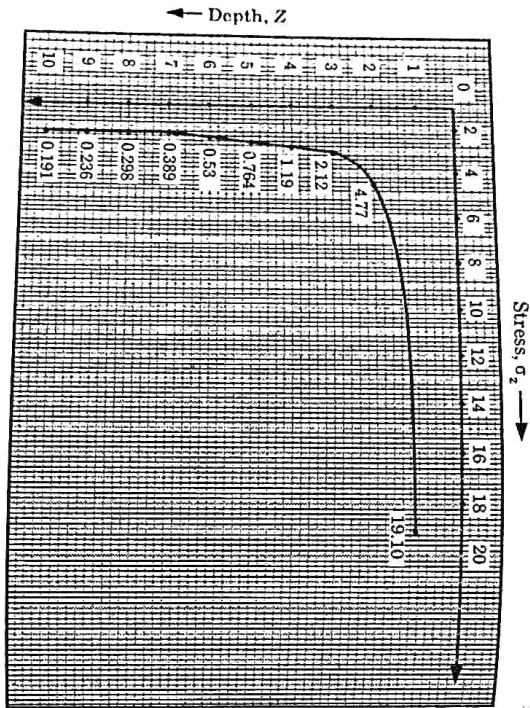

PART-2

Stress Distribution Under Loaded Areas, Concept of Pressure Bulb, Contact Pressure.

Questions-Answers

Long Answer Type and Medium Answer Type Questions

Que 4.7. Derive an expression for the vertical stress under a circular area. Determine the vertical stress at a point P which is 3 m below and at a radial distance of 3 m from the vertical load of 100 kN. Use Westergaard's solution.

AKTU 2017-18, Marks 10

Answer

Vertical Stresses Under a Circular Area :

- Let us determine the vertical stress at the point P at depth Z below the centre of a uniformly loaded circular area as shown in the Fig. 4.7.1.
- Let the intensity of the load be q per unit area and R be the radius of the loaded area. Boussinesq's solution can be used to determine σ_z .
- The load on the elementary ring of radius r and width dr is equal to $q(2\pi r) dr$.
- The load acts at a constant radial distance r from the point.

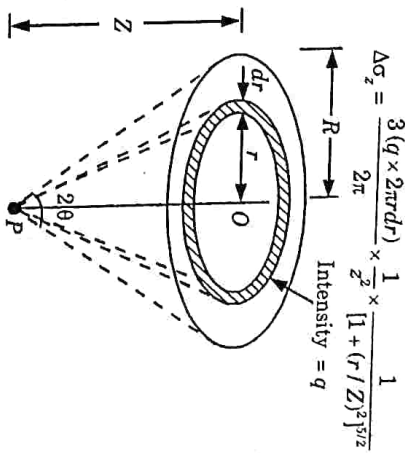

Fig. 4.7.1. Circular load.

5. The vertical stress due to entire load is given by,

$$\sigma_z = 3qZ^3 \int_0^R \frac{r dr}{(r^2 + Z^2)^{5/2}} \dots (4.7.1)$$

6. Let $r^2 + Z^2 = u$. Therefore, $2r dr = du$
Eq. (4.7.1) becomes,

$$\sigma_z = 3qZ^3 \int_{Z^2}^{(R^2 + Z^2)} \frac{du}{2u^{5/2}}$$

$$= \frac{3}{2} qZ^3 \left[-\frac{2}{3} \right] \left[u^{-3/2} \right]_{Z^2}^{R^2 + Z^2}$$

$$= -qZ^3 \left[\frac{1}{(R^2 + Z^2)^{3/2}} - \frac{1}{(Z^2)^{3/2}} \right]$$

$$= qZ^3 \left[\frac{1}{Z^3} \frac{1}{(R^2 + Z^2)^{3/2}} - \frac{1}{(Z^2)^{3/2}} \right]$$

$$\text{OR } \sigma_z = q \left[1 - \frac{1}{1 + (R/Z)^2} \right]^{3/2}$$

$$\text{OR } \sigma_z = I_c \times q$$

where I_c is the influence coefficient for the circular area, and is given by,

$$I_c = \left[1 - \left\{ \frac{1}{1 + (R/Z)^2} \right\}^{3/2} \right] \dots(4.7.2)$$

Eq. (4.7.2) for the influence coefficient I_c can be written in terms of the angle 2θ subtended at point P by the load.

Let $\tan \theta = R/Z$. Therefore

$$I_c = \left[1 - \left\{ \frac{1}{1 + \tan^2 \theta} \right\}^{3/2} \right] \dots(4.7.3)$$

$$I_c = 1 - (\cos^2 \theta)^{3/2} = 1 - \cos^3 \theta$$

Eq. (4.7.3) indicates that as θ tends to 90° , the value of I_c approaches unity. In other words, when a uniformly loaded area tends to be very large in comparison with the depth z , the vertical stress at the point P is approximately equal to q .

Numerical:

Given : Depth of point P, $Z = 3$ m
Load at point P, $Q = 100$ kN

Radial distance of point P, $r = 3$ m,
To Find : Vertical stress at point P.

Westergaard's equation is given by,

$$\sigma_z = \frac{Q}{\pi} \frac{1}{[1 + 2(r/Z)^2]^{3/2}} \times \frac{Z}{Z^2}$$

$$\sigma_z = \frac{1}{\pi [1 + 2(3/3)^2]^{3/2}} \times \frac{100}{(3)^2} = 0.681 \text{ kN/m}^2$$

Que 4.8. Derive an expression for the vertical stress for a line load and for a uniform load on strip area.

Answer

1. Line Load:

i. If the line load is of intensity q per unit length parallel to Y-axis on the surface of a semi-infinite elastic medium, the vertical stress σ_z at a point P, as shown in Fig. 4.8.1, is given by,

$$\sigma_z = \frac{2}{\pi} \times \frac{q}{Z} \cos^4 \beta \dots(4.8.1)$$

ii. Eq. (4.8.1) may also be expressed in the form,

$$\sigma_z = \frac{2q}{\pi Z} \left[\frac{1}{1 + (x/Z)^2} \right]^2 \dots(4.8.2)$$

where, Z is the depth of point P, and x is the horizontal distance of P along X-axis from the line load.

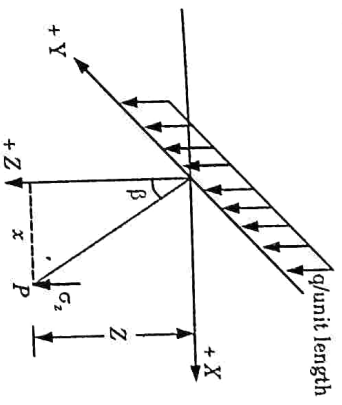

Fig. 4.8.1. Vertical stress due to line load.

Strip Load:

The vertical stress (σ_z) at a point P, due to a uniform load of intensity q on strip of width (B) and semi-infinite length (Fig. 4.8.2) is given by,

$$\sigma_z = \frac{q}{\pi} (2\theta + \sin 2\theta) \dots(4.8.3)$$

ii. If the point P is directly below the centre of the strip, i.e., $\phi = 0$, eq. (4.8.3) becomes

$$\sigma_z = \frac{q}{\pi} (2\theta + \sin 2\theta) \dots(4.8.4)$$

where, 2θ is the angle in radians subtended by the width of strip at point P.

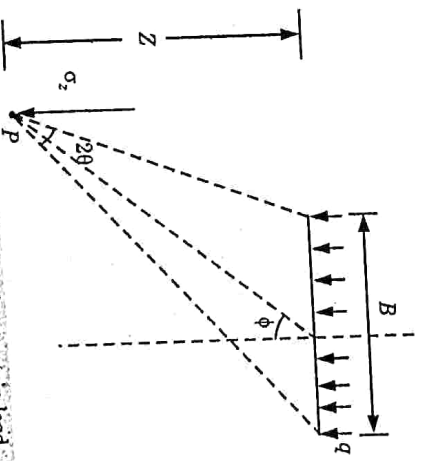

Fig. 4.8.2. Vertical stress due to strip load.

Que 4.9. A long strip footing of width 2 m carries a load of 350 kN/m. Calculate the maximum stress at a depth of 6 m below the centre line of footing.

Answer

Given : Width of footing, $B = 2$ m, Depth of point, $Z = 6$ m, Intensity of load = 350 kN/m.
To Find : Stress at a depth of 6 m below the centre.

1. Stress is given by, $\sigma_z = \frac{q}{\pi} (2\theta + \sin 2\theta)$
2. $\tan \theta = \frac{B/2 - Z}{Z} = \frac{1 - 6}{6} = -0.167 \Rightarrow \theta = 9.5^\circ$
 $2\theta = 0.33$ radian
3. $q = \frac{350}{2} = 175$ kN/m²
4. $\sigma_z = \frac{175}{\pi} (0.33 + 0.325) = 36.5$ kN/m².

Que 4.10. Two long boundary walls of small width run parallel to each other at a distance of 3 m apart. The self-weights of the walls are 25 kN/m and 15 kN/m. Plot the distribution of vertical stress intensity due to the walls on a horizontal plane 3 m below the ground level.

Answer

Given : Self weight of walls = 25 kN/m and 15 kN/m
Distance between walls = 3 m, Depth of plane = 3 m
To Find : Stress distribution.

1. Vertical stress due to line load at Z' in depth from the ground level.

$$\sigma_z = \frac{2q'}{\pi Z} \left[\frac{1}{1 + \left(\frac{x}{Z}\right)^2} \right]^2$$

$$\sigma_z = q'l$$

where,

$$l = \frac{2}{\pi Z} \left[\frac{1}{1 + \left(\frac{x}{Z}\right)^2} \right]^2$$

2. Vertical stress due to wall-A at 3 m depth from the ground level,
 $\sigma_A = q_A l_A = 25 \times l_A$
3. Vertical stress due to wall-B at 3 m depth from the ground level,
 $\sigma_B = q_B l_B = 15 \times l_B$
4. Vertical Stress Due to Wall-A:
At point A, $x = 0, Z = 3$ m

4-14 A (CE-Sem-5)

Stress Distribution in Soil & Shear Strength

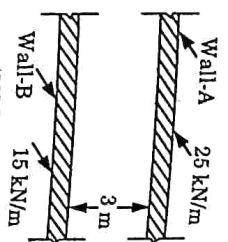

Fig. 4.10.1

- i. Stress under the wall - A, $\sigma_A = 5.30785$ kN/m²
At point B, $x = 3$ m, $Z = 3$ m

$$\sigma_A = 25 \times \left[\frac{2}{3 \times 3.14} \left(\frac{1}{1+0} \right) \right]^2$$

5. Vertical Stress Due to Wall-B:
i. At point B, $x = 0, Z = 3$

$$\sigma_B = 15 \times \left[\frac{2}{3 \times 3.14} \left(\frac{1}{1+0} \right) \right]^2$$

- ii. Stress under the wall = B, $\sigma_B = 3.1847$ kN/m²
At point A, $x = 3$ m, $Z = 3$ m

$$\sigma_B = 15 \times \left[\frac{2}{3 \times 3.14} \left(\frac{1}{1 + \left(\frac{3}{3}\right)^2} \right) \right]^2$$

6. Stress under the wall = A, $\sigma_B = 0.7962$ kN/m²
Stress Distribution :

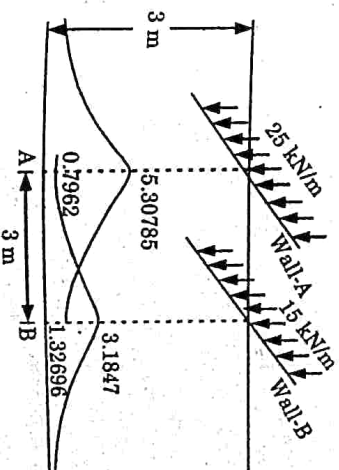

Fig. 4.10.2

Que 4.11: What do you understand by pressure isobars and pressure bulb? Give the importance of pressure bulb.

Answer

A Pressure Isobar and Pressure Bulb :

1. An isobar is a line which connects all points of equal stress below the ground surface. In other words, an isobar is a stress contour.
2. We may draw any number of isobars as shown in Fig. 4.11.1 for any given load system.
3. Each isobar represents a fraction of the load applied at the surface.
4. Since these isobars form closed figures and resemble the form of a bulb, they are also termed as bulb of pressure or simply the pressure bulb.
5. Normally isobars are drawn for vertical, horizontal and shear stresses.
6. The one that is most important in the calculation of settlements of footings is the vertical pressure isobar.

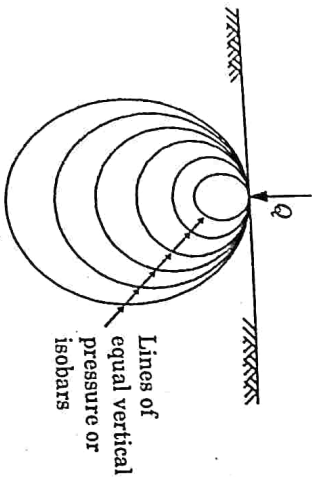

Fig. 4.11.1, Bulb of pressure.

B. Importance of Pressure Bulb :

1. In his opening discussion on settlement of structures at an International Conference held at Harvard University in 1936, Terzaghi advocated and stressed on the importance of the pressure bulb and its relationship with the seat of settlement.

As stated above, we may draw any number of isobars for any given load (such as isobars of $0.8q, 0.6q, \dots, 0.1q$), but the isobar that is of practical significance is the one which encloses a soil mass which is responsible for the settlement of the structure.

3. Terzaghi recommended that for all practical purposes, such a zone may be taken as the zone bounded by the vertical stress contour of value $0.2q$.
4. The depth where the vertical stress in the soil mass reduces to 0.2 times the foundation contact pressure is, thus, known as the significant depth (D_s).
5. The depth D_s , evidently, equals to $1.5B$ (approximately) for a square or a circular footing, where B is the width or diameter of the footing.

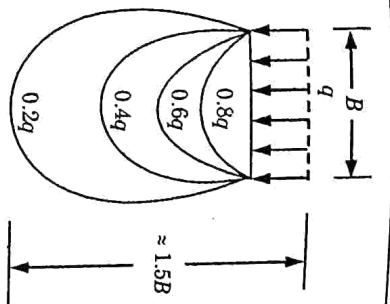

(a) Contours of equal vertical stress under a square area ($B \times B$).

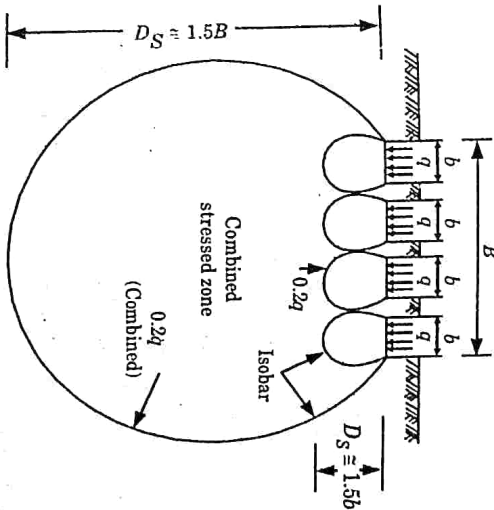

Fig. 4.11.2.

(b) Pressure bulb for closely spaced square footings (loaded areas).

Que 4.12: A water tank is supported by a ring foundation having outer diameter of 8 m and inner diameter of 6 m. The uniform load intensity on the foundation is 200 kN/m^2 . Compute the vertical stress caused by the water tank at a depth of 4 m below the centre of the foundation.

Answer

- Given :** Intensity of UDL = 200 kN/m^2 , $Z = 4 \text{ m}$, $D_o = 8 \text{ m}$, $D_i = 6 \text{ m}$
- To Find :** Vertical stress:
1. Boussinesq equation for uniform load on circular area is applicable to finding vertical stress under a wholly loaded circular area has been

extended to such cases where the entire circular area is not loaded and only a ring portion is loaded between radius R_o and R_i , as shown in Fig. 4.12.1.

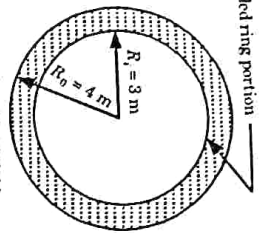

Fig. 4.12.1.

$$\sigma_z = q \left[1 - \frac{1}{1 + \left(\frac{R_o}{Z}\right)^2} \right]^{3/2} - q \left[1 - \frac{1}{1 + \left(\frac{R_i}{Z}\right)^2} \right]^{3/2} \dots(4.12.1)$$

where,

R_o = Outer radius of ring.

R_i = Inner radius of ring.

$D_o = 2R_o = 8 \text{ m} \Rightarrow R_o = 4 \text{ m}$

$D_i = 2R_i = 6 \text{ m} \Rightarrow R_i = 3 \text{ m}$

2. Here,

$$\sigma_z = 200 \left[1 - \frac{1}{1 + \left(\frac{4}{4}\right)^2} \right]^{3/2} - 200 \left[1 - \frac{1}{1 + \left(\frac{3}{4}\right)^2} \right]^{3/2}$$

$$= 200 \left[1 - \frac{1}{2} \right]^{3/2} - 200 \left[1 - \frac{1}{1.5625} \right]^{3/2}$$

$$= 200 [1 - 0.354] - 200 [1 - 0.512]$$

$$= 129.29 - 97.6 = 31.69 \text{ kN/m}^2$$

PART-3

Shear Strength : Mohr Coulomb Failure Criterion, Shear Strength Parameters and Determination, Direct and Tri-axial Shear Test, Unconfined Compression Test, Pore Pressure, Skempton's Pore Pressure Coefficients, and Soil Liquefaction.

Questions-Answers

Long Answer Type and Medium Answer Type Questions

Que 4.13. What is Mohr's circle ? Discuss its important characteristics.

AKTU 2017-18, Marks 02

Answer

Mohr's Circle :

- Mohr's circle is a graphical representation of a general state of stress at a point.
 - It can be shown that the locus of stress coordinates (σ, τ) for all planes through a point is a circle, the Mohr circle of stress.
 - To draw a Mohr circle, the normal stress σ is plotted along the X-axis and shear is plotted along the Y-axis.
 - This method is used for evaluation of principal stresses, maximum shear stress, normal and tangential stresses on any given plane.
- Characteristics :** Following are the important characteristics of Mohr's circle :
- The maximum shear stress τ_{max} is numerically equal to $(\sigma_1 - \sigma_3)/2$ and it occurs on a plane inclined at 45° to the principal planes as shown in Fig. 4.13.1.
 - Point D on the Mohr circle represents the stresses (σ, τ) on a plane make an angle θ with the major principal plane.

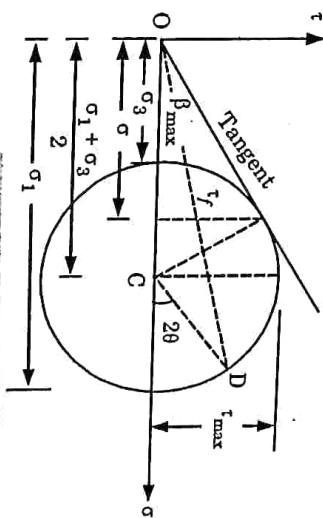

Fig. 4.13.1. Mohr's circle.

- Shear stresses on planes at right angles to each other are numerically equal but are of opposite signs.
- Que 4.14.** Describe the Mohr-Coulomb failure theory.

Answer

- According to Mohr, the failure is caused by a critical combination of the normal and shear stresses.
- When the soil sample has failed, the shear stress on the failure plane defines the shear strength of the soil. Thus it is necessary to identify the failure plane.

- Failure of the material occurs when the Mohr circle of the stresses touches the Mohr envelope.
- At the point of contact (D) of the failure envelope on the Mohr circle, the critical combination of shear and normal stresses is reached and the failure occurs. The plane indicated by the line PD is, therefore, the failure plane.
- Any Mohr's circle which lies below the failure envelope represents a (non-failure) stable condition.
- The Mohr-Coulomb failure criterion can be written as the equation for the line that represents the failure envelope. The general equation is, where,

$$s = c + \sigma \tan \phi$$

s = Shear strength on the failure plane.
 c = Cohesion strength.
 σ = Normal stress on the failure plane.
 ϕ = Angle of internal friction.

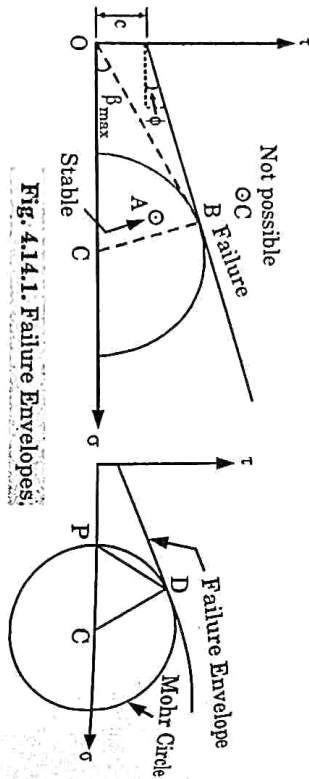

Fig. 4.14.1. Failure Envelopes.

Que 4.15. Describe direct shear test. What are its merits and demerits ?

Answer

Direct Shear Test :

- A direct shear test is a laboratory or field test used by geotechnical engineers to measure the shear strength properties of soil or rock material.
- The original form of apparatus for the direct application of shear force is the shear box.
- The apparatus consists of a square brass box split horizontally at the level of the center of the soil sample, which is held between metal grilles and porous stones as shown in Fig. 4.15.1.
- Vertical load is applied to the sample as shown in the Fig. 4.15.1 and is held constant during a test.
- A gradually increasing horizontal load is applied to the lower part of the box until the sample fails in shear.
- The shear load at failure is divided by the cross-sectional area of the sample to give the ultimate shearing strength.

- The vertical load divided by the area of the sample gives the applied vertical stress σ .
- A proving ring is fitted to the upper half of the box to measure the shear force. As the box moves, the proving ring records the shear force.

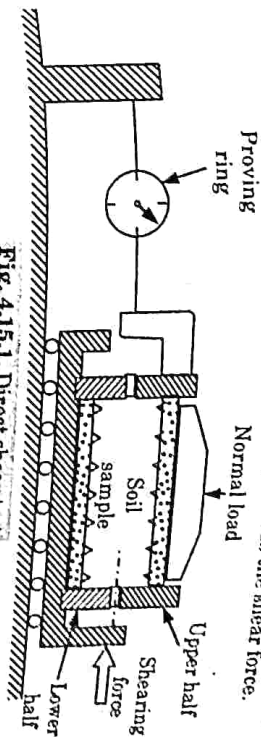

Fig. 4.15.1. Direct shear test.

Merits : Following are the merits of direct shear test :

- A direct shear machine is simple and fast to operate.
 - Direct shear requirement is much less expensive as compared to other tests.
 - It is easy to test sands and gravels.
 - Large samples can be tested in large shear boxes, as small samples can give misleading results.
- Demerits :** Following are the demerits of direct shear test :
- The distribution of normal and shear stress along the predetermined failure plane is very complex.
 - Drainage condition during this test cannot be controlled as the water content of a saturated soil changes rapidly with stress.
 - The area of the failure plane is not constant during the direct shear test. This area will be less than the original area of the soil specimen.
 - The soil is sheared on a predetermined horizontal plane. This forced plane is not necessarily the weakest plane. This is the most important limitation of the direct shear test.
 - The effect of internal restraint by the side walls of the shear box is likely to affect the results.
 - The measurement of pore water pressure is not possible.

Que 4.16. Describe the triaxial shear test. What are the advantages of triaxial shear test over the direct shear test ?

Answer

Triaxial Compression Test :

- A diagrammatic layout of a triaxial test apparatus is shown in Fig. 4.16.1.
- In the triaxial compression test, three or more identical samples of soil are subjected to uniformly distributed fluid pressure around the cylindrical surface.
- The sample is sealed in a watertight rubber membrane.
- Then axial load is applied to the soil sample until it fails.

- Although only compressive load is applied to the soil sample, it fails by shear on internal faces.
- It is possible to determine the shear strength of the soil from the applied loads at failure.

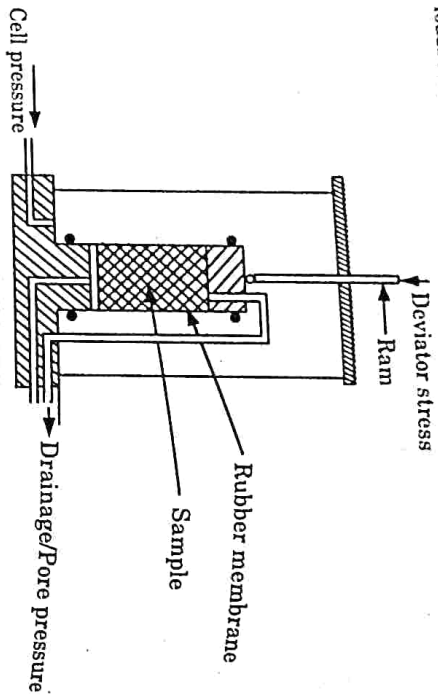

Fig. 4.16.1.

Advantages of Triaxial Test over the Direct Shear Test :

- The soil samples are subjected to uniform stresses and strains.
- Different combinations of confining and axial stresses can be applied.
- Drained and undrained tests can be carried out.
- Pore water pressures can be measured in undrained tests.
- The complete stress-strain behaviour can be determined.
- The triaxial machine is more adaptable.

Que 4.17. Explain the unconfined compression test.

OR

Describe the unconfined compression test ? What is its advantage over a triaxial test ?

AKPTU 2019-20, Marks 07

Answer

Unconfined Compression Test :

- Unconfined compression or uniaxial compression test is a special case of a triaxial test.
- The unconfined compression test is performed on unconfined cylindrical specimen of a cohesive soil to measure its unconfined compression strength.
- It is carried out without any confining pressure and the triaxial cell assembly is not required, making the test procedure simpler.
- It is carried out on saturated clay specimens that can stand unsupported.
- The clay specimen is loaded axially where the load is increased to failure. The loading is carried out quickly.

- During the loading, the axial shortening of the specimen and the applied load are measured at certain intervals from which the stress-strain plot can be generated and the unconfined compressive strength.
- This is a simpler but less reliable method.

Advantages of unconfined compression test over triaxial test :

- The test is convenient simple and quick.
- It is suited for measuring the unconsolidated-undrained shear strength of saturated clays.
- The sensitivity of the soil may be easily determined by conducting the test on an undisturbed sample and then on the remoulded sample.

Que 4.18. Describe the vane shear test. What are the merits and demerits of vane shear test.

Answer

Vane Shear Test :

- This test provides a simple and quick method of determining the undrained (vane) shear strength of relatively soft clays.
- It is a rotational shear test, in which a cylindrical volume of clay is made to rotate by a cruciform vane pushed into the clay.
- The opposing shear resistance between the cylinder and the surrounding material is determined from the torque applied to the vane, which is measured by means of a calibrated torsion spring and hence the shear strength of the clay can be calculated.
- The shear strength of the soil is determined using the formula,

$$T = \pi s [D^2 H / 2 + D^3 / 6]$$

where,

T = Applied torque.

H = Height of vane.

D = Diameter of vane.

s = Undrained shear strength.

Merits : Following are the merits of vane shear test :

- The test is simple and quick.
- It is ideally suited for the determination of the in-situ undrained shear strength of non-fissured fully saturated clay.
- The test can be conveniently used to determine the sensitivity of the soil.

Demerits : Following are the demerits of vane shear test :

- The test cannot be conducted on the fissured clay or the clay containing sand or silt laminations.
- The test does not give accurate results when the failure envelope is not horizontal.

Que 4.19. What are the advantages and disadvantages of triaxial compression test ?

AKPTU 2015-16, Marks 10

Answer

Advantages : Following are the various advantages of triaxial compression test :

1. There is complete control over the drainage conditions. Tests can be easily conducted for all three types of drainage conditions.
2. Pore pressure changes and the volumetric changes can be measured directly.
3. The stress distribution on the failure plane is uniform.
4. The specimen is free to fail on the weakest plane.
5. The state of stress at all intermediate stages upto failure is known. The Mohr circle can be drawn at any stage of shear.
6. The test is suitable for accurate research work.

Disadvantages : Following are the disadvantages of triaxial compression test :

1. The apparatus is elaborate, costly and bulky.
2. The drained test takes a longer period as compared with that in a direct shear test.
3. It is not possible to determine the cross-sectional area of the specimen accurately at large strains, as the assumption that the specimen remains cylindrical does not hold good.
4. The test simulates only axis-symmetrical problems. In the field, the problem is generally 3-dimensional. A general test in which all the three stresses are varied would be more useful.
5. The consolidation of the specimen in the test is isotropic whereas in the field, the consolidation is generally anisotropic.

Que 4.20. Classify shear tests based on drainage conditions.

Answer

Types of Shear Test : Depending on whether drainage is permitted during the consolidation stage and the shear stage, the test conducted on the saturated soils for determining the shear strength are classified as follows :

A. Unconsolidated Undrained Test (UU Test) :

1. Drainage is not permitted at any stage of the test, that is, either before the test during the application of the normal stress or during the test when the shear stresses are applied.
2. In this test a minimum of three soil samples are subjected to different confining pressures σ_3 and then loaded to failure. The resulting Mohr's envelope will be as shown in Fig. 4.20.1.

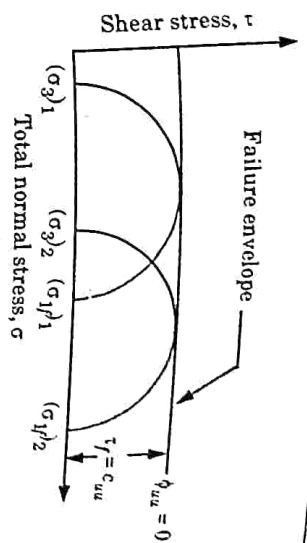

Fig. 4.20.1.

3. The Fig. 4.20.1 is drawn with total stresses and hence, defines total stress parameters. The failure envelope is horizontal and shear strength is given by,

$$\tau_f = c_{cu}$$

where c_{cu} = Cohesion intercept in unconsolidated undrained test. Angle of shearing resistance ϕ_{cu} is zero.

B. Consolidated Undrained Test (CU Test) :

1. Drainage is permitted fully in this type of test during the application of the normal stress and no drainage is permitted during the application of the shear stress.
2. In this test soil sample is initially consolidated under confining pressure. This pressure is known as initial effective confining pressure ($\bar{\sigma}_c$).
3. After consolidation, the confining pressure and pore water pressure may be increased by the same amount thus keeping the effective stress still constant at $\bar{\sigma}_c$. This operation is called application of back pressure, u_B . Back pressure is applied in order to saturate the soil sample and to facilitate measurement of negative pore water pressure during application of deviatoric stress in the case of overconsolidated clays.
4. The soil sample is sheared under this elevated cell pressure σ_3 and it fails at a vertical axial stress of σ_1 . Mohr's circles for determination of total stress parameters are drawn with $(\sigma_1 - u_B)$ and $(\sigma_3 - u_B) = \bar{\sigma}_c$ as major and minor total principal stresses at failure, respectively. The resulting failure envelope is shown in Fig. 4.20.2.
5. Shear strength of soil can be expressed as,

$$\tau_f = c_{cu} + \sigma \tan \phi_{cu}$$

where c_{cu} and ϕ_{cu} are total stress parameters from consolidated undrained test.

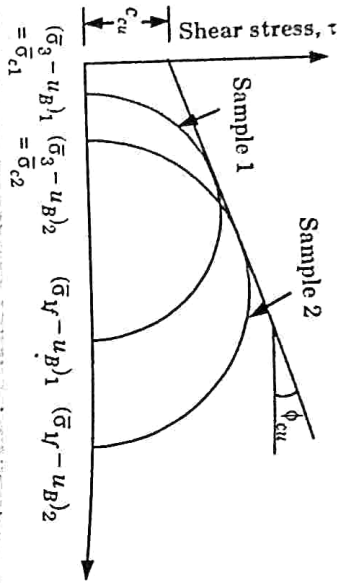

Fig. 4.20.2. Total stress failure envelope for c_u test.

C. Drained Test (CD Test):

1. Drainage is permitted fully before and during the test at every stage.
2. In consolidated drained test the sample is first consolidated under confining pressure. Then the sample is sheared under the same confining pressure. Thus in this test $\sigma_3 = \bar{\sigma}_c$.
3. Drainage is permitted during shearing of sample. Hence, the pore water pressure at all stages of test is zero and always effective stress prevails.
4. Mohr's circles in terms of effective major and minor principal stresses at failure $\bar{\sigma}_{1f}$ and $\bar{\sigma}_{3f} = \bar{\sigma}_c$, respectively, can be drawn to get effective stress parameters. The failure envelope for the test is shown in Fig. 4.20.3.

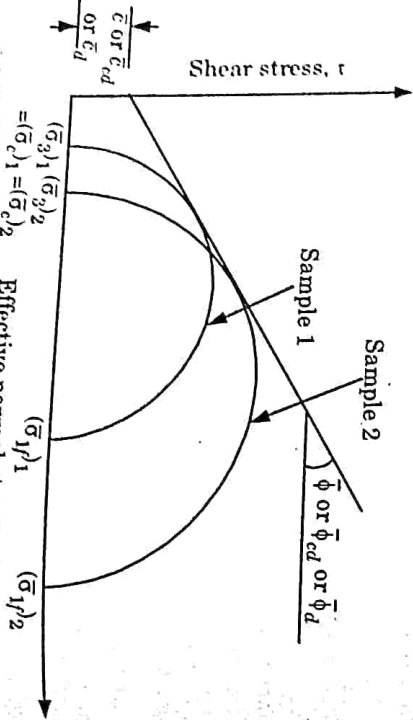

Fig. 4.20.3. Effective stress failure envelope for CD test.

5. Shear strength is expressed as,

$$\tau_f = \bar{\sigma}_c + \bar{\sigma} \tan \bar{\phi}_{cd} = \bar{\sigma}_c + \bar{\sigma} \tan \bar{\phi}_u$$

6. The soil is consolidated under the applied normal stresses and is tested for shear by applying the shear stress also very slowly while drainage is permitted at every stage.
7. In the case of cohesive soils although not so much time is required in the case of cohesionless soils as the latter drain off quickly.
8. This test is also called CD test and slow test.

Que 4.21.

Write about the consolidated - undrained test for finding out the shear strength parameters. Also show and explain the curves between the deviator stress versus axial strain (for loose and dense sand both) and variation of pore water pressure versus axial strain (for loose and dense sand both).

Answer

A. Consolidated Undrained Test : Refer Q. 4.20, Page 4-23A, Unit-4.

B. Curves :

1. Curve between Deviator Stress and Axial Strain :
 - i. The Y-axis shows the deviator stress and the X-axis, the axial strain (ϵ_x).
 - ii. For dense sand (and over-consolidated clay), the deviator stress reaches a peak value and then it decreases and becomes almost constant, equal to the ultimate stress, at large strains as shown in Fig. 4.21.1.
 - iii. For loose sand (and normally consolidated clay), the deviator stress increases gradually till the ultimate stress is reached.

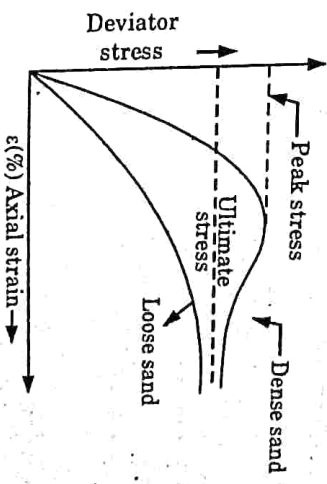

Fig. 4.21.1. Deviator stress vs. axial strain.

Curve between Pore Water Pressure and Axial Strain :

1. In a consolidated undrained test, there is an increase in the pore water pressure throughout for loose sand (and normally consolidated clay), as shown in Fig. 4.21.2.
- ii. However, in the case of dense sands (and over-consolidated clay), the pore water pressure increases at low strains but at large strains it becomes negative (below atmospheric pressure).

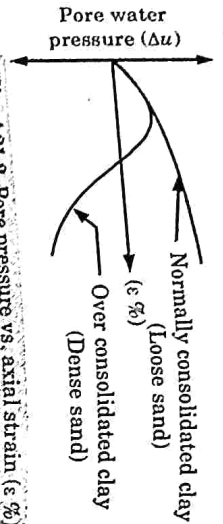

Fig. 4.21.2. Pore pressure vs. axial strain (ε %).

Que 4.22. What are the Skempton's pore pressure parameters? Derive an expression between pore water pressure and applied stress.

AKTU 2015-16, Marks 16
AKTU 2016-17, Marks 10

Answer

A. Skempton's Pore Pressure Parameters :

1. Skempton introduced a simple concept to estimate the change in pore water pressure (Δu) in a soil element due to the changes in major and minor total principle stresses ($\Delta\sigma_1$ and $\Delta\sigma_3$) in undrained loading.
2. There are two type of pore pressure parameter B and A .
 - i. B = It can be defined as the ratio of change in the pore water pressure with the change in the cell pressure.
 - ii. A = It can be defined as the ratio of change in the pore water pressure with the change in the deviator stress.

B. Expression of Pore Pressure Parameters under Deviator Stress:

1. Let us consider the element of a saturated soil which is in equilibrium under three principal stresses σ_1, σ_2 and σ_3 , are shown in Fig. 4.22.1.

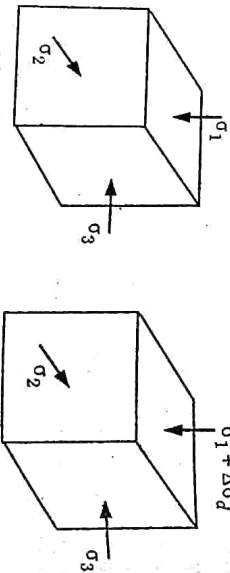

Fig. 4.22.1. Pore pressure under deviator stress.

2. When the element is subjected to a deviator stress $\sigma_d (= \sigma_1 - \sigma_3)$, let the increase in pore water pressure be Δu_d . The changes in the effective stresses in the three directions are given by,

$$\Delta\bar{\sigma}_1 = \Delta\sigma_d - \Delta u_d \quad \dots(4.22.1)$$

$$\Delta\bar{\sigma}_2 = - \Delta u_d \quad \dots(4.22.2)$$

$$\Delta\bar{\sigma}_3 = - \Delta u_d \quad \dots(4.22.3)$$

3. In an elastic material, the volumetric strain $\Delta V_0 / V_0$ is equal to the sum of the linear strains in three directions, and is given by,

$$\frac{\Delta V_0}{V_0} = \Delta\epsilon_1 + \Delta\epsilon_2 + \Delta\epsilon_3$$

where,

$$\epsilon_1 = \text{Strain in the direction-1} = \frac{\Delta\bar{\sigma}_1}{E} - \mu \left(\frac{\Delta\bar{\sigma}_2}{E} + \frac{\Delta\bar{\sigma}_3}{E} \right)$$

$$\epsilon_2 = \text{Strain in the direction-2} = \frac{\Delta\bar{\sigma}_2}{E} - \mu \left(\frac{\Delta\bar{\sigma}_1}{E} + \frac{\Delta\bar{\sigma}_3}{E} \right)$$

$$\epsilon_3 = \text{Strain in the direction-3} = \frac{\Delta\bar{\sigma}_3}{E} - \mu \left(\frac{\Delta\bar{\sigma}_1}{E} + \frac{\Delta\bar{\sigma}_2}{E} \right)$$

$$\frac{\Delta V_0}{V_0} = \frac{1-2\mu}{E} (\Delta\bar{\sigma}_1 + \Delta\bar{\sigma}_2 + \Delta\bar{\sigma}_3)$$

$$\frac{\Delta V_0}{V_0} = \frac{3(1-2\mu)}{E} \left(\frac{\Delta\bar{\sigma}_1 + \Delta\bar{\sigma}_2 + \Delta\bar{\sigma}_3}{3} \right) \quad \dots(4.22.4)$$

Because the soil is not a purely elastic material, eq. (4.22.4) for soils is modified as,

$$\frac{\Delta V_0}{V_0} = C_c \left(\frac{\Delta\bar{\sigma}_1 + \Delta\bar{\sigma}_2 + \Delta\bar{\sigma}_3}{3} \right) \quad \dots(4.22.5)$$

where C_c is the coefficient of volume compressibility of the soil.

5. Substituting the values of $\Delta\bar{\sigma}_1, \Delta\bar{\sigma}_2$, and $\Delta\bar{\sigma}_3$ from eq. (4.22.1), (4.22.2) and (4.22.3) in eq. (4.22.5), we get

$$\frac{\Delta V_0}{V_0} = C_c \left(\frac{\Delta\sigma_d - \Delta u_d - \Delta u_d - \Delta u_d}{3} \right) \quad \dots(4.22.6)$$

6. As in the case of isotropic consolidation, the reduction in the volume of fluid in voids is given by,

$$\Delta V_0 = C_v (nV_0) \Delta u_d \quad \dots(4.22.7)$$

7. As the change in the volume of the soil mass is equal to the reduction in the volume of voids,

$$\frac{C_c}{3} (\Delta\sigma_d - 3 \Delta u_d) V_0 = C_c (n V_0) \Delta u_d$$

$$\Delta u_d (n C_c + C_c) V_0 = C_c V_0 (\Delta\sigma_d / 3)$$

$$\Delta u_d = \left(\frac{C_c}{n C_c + C_c} \right) \left(\frac{\Delta\sigma_d}{3} \right)$$

$$\Delta u_d = \frac{1}{\left(1 + \frac{n C_c}{C_c} \right)} \times \left(\frac{1}{3} \right) (\Delta\sigma_d)$$

8. Because a soil is not perfectly elastic, the constant 1/3 is replaced by A in the above expression. Thus,

$$\Delta u_d = \frac{A}{\left(1 + \frac{n C_c}{C_c} \right)} \times (\Delta\sigma_d)$$

$$\Delta u_d = AB (\Delta\sigma_d)$$

Eq. (4.22.8) can also be written as,

$$\Delta u_d = \bar{A} (\Delta\sigma_d)$$

where,

$$\bar{A} = A \times B$$

9. For a fully saturated soils, \bar{A} is also equal to A, as B is unity.

The value of the pore pressure parameter A can be determined experimentally in a triaxial test.

Que 4.23. What is the significance of the pore pressure coefficients? Illustrate the answer by an example. How are the pore pressure parameters A and B determined?

Answer

A. Significance :

- Skempton's pore pressure parameters are very useful in field problems where pore pressures that are induced consequent to change in the total stress may have to be computed.
- Pore water pressure play a very important role in determining the shear strength of soil.

B. Example :

- Embankment constructed rapidly over a soft clay deposit.
- Large earth dam constructed rapidly with no change in water content of soft clay.
- Footings placed rapidly on clay deposit.

Determination of parameter A and B :

- Parameter B can be determined in a \overline{UU} test. The cell pressure is increased by $\Delta\sigma_3$ and the corresponding increase in pore pressure Δu_1 is measured in the first stage of the triaxial test. Then, $B = \Delta u_1 / \Delta\sigma_3$.
- Parameter \bar{A} is measured during the second stage of the triaxial test. If Δu_2 is the pore pressure increase due to an increase in deviator stress of $(\Delta\sigma_1 - \Delta\sigma_3)$ with cell pressure being constant, $\bar{A} = \Delta u_2 / (\Delta\sigma_1 - \Delta\sigma_3)$. For a completely saturated soil, $A = \bar{A}$.
- For a fully saturated soil, parameter A can also be determined easily in a \overline{CU} test. In this test, since $\Delta\sigma_3 = 0$ when the deviator stress is applied, $A = \Delta u / (\Delta\sigma_1 - \Delta\sigma_3) = \Delta u / \Delta\sigma_1$.

Que 4.24 A series of consolidated undrained tests on a soil gave the following results : $C_{CU} = C'_{CU} = 0$; $\phi_{CU} = \phi'_{CU} = 30^\circ$. A sample of this soil was rested in a consolidated undrained test under a cell pressure of 150 kN/m². Determine :

- Deviator stress at failure.
- Pore water pressure at failure.
- Minor principal effective stress at failure.
- Major principal effective stress at failure.
- The magnitude of A_f .

Answer

Given : $C_{CU} = C'_{CU} = 0$, $\phi_{CU} = \phi'_{CU} = 30^\circ$, Cell pressure = 150 kN/m²

To Find : Deviator stress, Pore water pressure, Minor principal and Major principal effective stress and Magnitude of A_f

$$1. \quad \sigma_{1f} = \sigma_{3f} \frac{1 + \sin \phi_u}{1 - \sin \phi_u}, \text{ since } c_u = 0$$

Deviator stress

$$(\sigma_1 - \sigma_3)_f = \sigma_{3f} \frac{(1 + \sin \phi_u)}{(1 - \sin \phi_u)} - \sigma_{3f}$$

$$= \frac{(2\sigma_{3f} \sin \phi_u)}{(1 - \sin \phi_u)}$$

$$= \frac{2 \times 150 \times \sin 15^\circ}{1 - \sin 15^\circ}$$

$$\left[\because \phi_u = \frac{30}{2} = 15^\circ \right]$$

$$(\sigma_1 - \sigma_3)_f = 104.7 \text{ kN/m}^2$$

$$\sin \phi_u = \frac{(\sigma_1 - \sigma_3)_f}{(\sigma_1 + \sigma_3)_f}$$

$$\dots (4.24.1)$$

$$\sin \phi' = \frac{(\bar{\sigma}_1 - \bar{\sigma}_3)_f}{(\bar{\sigma}_1 + \bar{\sigma}_3)_f} = \frac{(\sigma_1 - \sigma_3)_f}{(\sigma_1 + \sigma_3)_f - 2u_f} \quad \dots(4.24.2)$$

Eq. (4.24.1) is divided by eq. (4.24.2), we get

$$\frac{\sin \phi_u}{\sin \phi'} = \frac{(\sigma_1 + \sigma_3)_f - 2u_f}{(\sigma_1 + \sigma_3)_f} = 1 - \frac{2u_f}{(\sigma_1 + \sigma_3)_f + 2\sigma_{3f}}$$

$$\frac{\sin 15^\circ}{\sin 30^\circ} = 1 - \frac{2u_f}{104.7 + 2 \times 150}$$

$$u_f = 97.6 \text{ kN/m}^2$$

3. $\bar{\sigma}_{3f} = \sigma_{3f} - u_f = 150 - 97.6 = 52.4 \text{ kN/m}^2$
4. $\bar{\sigma}_{1f} = (\bar{\sigma}_1 - \bar{\sigma}_3)_f + \bar{\sigma}_{3f} = 104.7 + 52.4 = 157.1 \text{ kN/m}^2$
5. $A_f = \frac{u_f}{(\sigma_1 - \sigma_3)_f} = \frac{97.6}{104.7} = 0.93$

Que 4.25. According to Mohr - Coulomb criterion, how is the failure plane recognized and how is shear strength defined?

The effective stress shear strength parameters of completely saturated clay are: $c' = 20 \text{ kN/m}^2$, $\phi' = 25^\circ$. A sample of this clay was tested in a unconsolidated undrained test under a cell pressure of 200 kN/m^2 and the principal stress difference at failure was 110 kN/m^2 . What was the value of pore water pressure at failure?

AKTU 2017-18, Marks 10

- A. Mohr Coulomb Theory: Refer Q. 4.14, Page 4-18A, Unit-4.
- B. Numerical:

Given: $c' = 20 \text{ kN/m}^2$, $\phi' = 25^\circ$, $\sigma_3 = 200 \text{ kN/m}^2$, $(\sigma_1 - \sigma_3)_f = 110 \text{ kN/m}^2$

To Find: Pore water pressure at failure.

1. $(\bar{\sigma}_1 - \bar{\sigma}_3) = (\sigma_1 - u) - (\sigma_3 - u) = (\sigma_1 - \sigma_3) = 110 \text{ kN/m}^2$

2. We know that, $(\bar{\sigma}_1 - \bar{\sigma}_3) = (\bar{\sigma}_1 + \bar{\sigma}_3) \sin \phi' + 2c' \cos \phi'$

$$110 = (\bar{\sigma}_1 + \bar{\sigma}_3) \sin 25^\circ + 2 \times 20 \times \cos 25^\circ$$

$$\bar{\sigma}_1 + \bar{\sigma}_3 = 174.5 \quad \dots(4.25.1)$$

$$\bar{\sigma}_1 - \bar{\sigma}_3 = 110 \quad \dots(4.25.2)$$

3. On solving eq. (4.25.1) and (4.25.2), we get $\bar{\sigma}_3 = 32.25 \text{ kN/m}^2$
4. Pore water pressure of failure, $u = \sigma_3 - \bar{\sigma}_3 = 200 - 32.25 = 167.75 \text{ kN/m}^2$

Que 4.26. In a tri-axial test of soil, specimen was consolidated under a cell pressure of 700 kN/m^2 and the increased pore pressure reading was 450 kN/m^2 . The axial load was then increased to give a deviator stress of 570 kN/m^2 and pore pressure reading of 650 kN/m^2 . Calculate the pore pressure parameters A and B.

Answer

Given: Cell pressure = 700 kN/m^2 , Deviator stress = 570 kN/m^2
 Pore pressure = 650 kN/m^2 , Increased pore pressure = 450 kN/m^2
 To Find: Pore pressure parameters A and B.

Assume back pressure = 360 kN/m^2 , increase cell pressure = 800 kN/m^2 .

1. For an increase in cell pressure from 700 to 800 kN/m^2 , the pore pressure increases from the value of back pressure 360 to 450 kN/m^2 .

2. Hence, $B = \frac{\Delta u_1}{\Delta \sigma_3} = \frac{450 - 360}{800 - 700} = \frac{90}{100} = 0.90$

3. An increase in total major principal stress from 800 kN/m^2 to $(800 + 570) \text{ kN/m}^2$, produced a corresponding increase in pore water pressure from 450 to 650 kN/m^2 .

4. Hence, $\bar{A} = \frac{\Delta u_2}{\Delta \sigma_1 - \Delta \sigma_3} = \frac{650 - 450}{570} = \frac{200}{570} = 0.3508$

$$\bar{A} = AB$$

$$A = \frac{0.3508}{0.90} = 0.39$$

Que 4.27. In an in-situ vane shear test on saturated clay, a torque of 35 N-m was required to shear the soil. The diameter of the vane was 50 mm and length 100 mm . Calculate the undrained shear strength of the clay. The vane was then rotated rapidly to cause remoulding of the soil. The torque required to shear the soil in the remoulded state was 5 N-m . Determine the sensitivity of the clay.

AKTU 2017-18, Marks 10

Answer

Given: Torque, $T = 35 \text{ N-m}$, Diameter of vane, $D = 50 \text{ mm}$
 Length of vane, $H = 100 \text{ mm}$, Remoulding torque, $T = 5 \text{ N-m}$
 To Find: Undrained shear strength and Sensitivity of clay.

1. Undrained shear strength,

$$s = \frac{T}{\pi(D^2 H/2 + D^3/6)} = \frac{35}{\pi[(0.05)^2 \times 0.1/2 + (0.05)^3/6]}$$

$$s = 76394.37 \text{ N/m}^2$$

2. In the remoulded state,

$$s_{rem} = \frac{5}{\pi[(0.05)^2 \times 0.1/2 + (0.05)^3/6]} = 10913.48 \text{ N/m}^2$$

3. Sensitivity = $\frac{s}{s_{rem}} = \frac{76394.37}{10913.48} = 7$

VERY IMPORTANT QUESTIONS

Following questions are very important. These questions may be asked in your SESSIONALS as well as UNIVERSITY EXAMINATION.

Q.1. Write short notes on :

- A. Boussinesq's analysis.
- B. Westergaard's analysis.

And also, write comparison between these two analyses.

ANS: Refer Q. 4.1, Unit-4.

Q.2. A concentrated load of 30 kN acts on the surface of a homogeneous soil mass of large extent. Find the stress intensity at a depth of 8 m and (i) directly under the load; (ii) at a horizontal distance of 6 m.

ANS: Refer Q. 4.2, Unit-4.

Q.3. A rectangular area 2 m x 4 m carries a uniform load of 8 t/m² at the ground surface. Find the vertical pressure at 5 m below the centre and corner of the loaded area.

ANS: Refer Q. 4.4, Unit-4.

Q.4. Derive an expression for the vertical stress under a circular area. Determine the vertical stress at a point P which is 3 m below and at a radial distance of 3 m from the vertical load of 100 kN. Use Westergaard's solution.

ANS: Refer Q. 4.7, Unit-4.

Q.5. Two long boundary walls of small width run parallel to each other at a distance of 3 m apart. The self-weights of the walls are 25 kN/m and 15 kN/m. Plot the distribution of vertical stress intensity due to the walls on a horizontal plane 3 m below the ground level.

ANS: Refer Q. 4.10, Unit-4.

Q.6. Describe the Mohr-Coulomb failure theory.

ANS: Refer Q. 4.14, Unit-4.

Q.7. Describe direct shear test. What are its merits and demerits?

ANS: Refer Q. 4.15, Unit-4.

Q.8. Describe the vane shear test. What are the merits and demerits of vane shear test.

ANS: Refer Q. 4.18, Unit-4.

Q.9. What are the advantages and disadvantages of triaxial compression test?

ANS: Refer Q. 4.19, Unit-4.



5 UNIT

Earth Pressure and Stability of Slopes

CONTENTS

Part-1 : Earth Pressure : Classical Theories,..... 5-2A to 5-12A
Coulomb and Rankine's Approaches
For Frictional and $c-\phi$ Soils,
Inclined Back Fill, Graphical Methods
of Earth Pressure Determination.

Part-2 : Stability of Slopes : Finite and 5-12A to 5-27A
Infinite Slopes, Types of Slope Failure,
Culmann's Method and Method of
Slices, Stability Number and Chart,
Bishop's Method

5-2 A (CE-Sem-5)

Earth Pressure and Stability of Slopes

PART-1

Earth Pressure Classical Theories, Coulomb and Rankine's Approaches For Frictional and $c-\phi$ Soils, Inclined Back Fill, Graphical Methods of Earth Pressure Determination.

Questions-Answers

Long Answer Type and Medium Answer Type Questions

Que 5.1. What are the different types of earth pressure ? Give examples.

Answer

Types of Earth Pressure : Lateral earth pressure can be grouped into three categories, depending upon the movement of the retaining wall with respect to the soil retained :

1. **At-rest Pressure :**
 - i. The lateral earth pressure is called at-rest pressure when the soil mass is not subjected to any lateral yielding or movement.
 - ii. This case occurs when the retaining wall is firmly fixed at its top and is not allowed to rotate or move laterally.
 - iii. Fig. 5.1.1(a) shows the basement retaining walls which are restrained against the movement by the basement slab provided at their tops.
2. **Active Pressure :**
 - i. A state of active pressure occurs when the soil mass yields in such a way that it tends to stretch horizontally.
 - ii. A retaining wall when moves away from the backfill, there is a stretching of the soil mass and the active state of earth pressure exists.
 - iii. In Fig. 5.1.1(b), the active pressure develops on the right-hand side when the wall moves towards left.
3. **Passive Pressure :**
 - i. A state of passive pressure exists when the movement of the wall is such that the soil tends to compress horizontally.
 - ii. In Fig. 5.1.1(b), the passive pressure develops on the left-side of the wall below the ground level, as the soil in this zone is compressed when the movement of the wall is towards right.

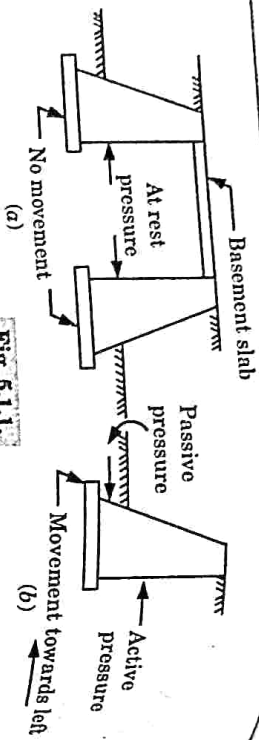

Fig. 5.1.1.

Que 5.2. What are the assumptions of Rankine's theory of earth pressure? Derive an expression for active earth pressure for dry or moist backfill with no surcharge.

Answer

Assumptions : Following are the assumptions made by Rankine for the derivation of earth pressure :

1. The soil mass is homogeneous and semi-infinite.
2. The soil is dry and cohesionless.
3. The ground surface is plane, which may be horizontal or inclined.
4. The back of the retaining wall is smooth and vertical.
5. The soil element is in a state of plastic equilibrium, i.e., at the verge of failure.

Derivation For Active Earth Pressure :

1. Let us consider an element of dry soil at a depth Z below a level soil surface.
2. Initially, the element is at rest conditions, and the horizontal pressure is given by,

$$\sigma_h = K_0 \sigma_v$$

where, σ_v is the vertical stress at C , and σ_h is the horizontal stress at C .
Vertical stress, $\sigma_v = \gamma Z$.

3. The stresses σ_h and σ_v are respectively, the minor and major principal stresses, and are indicated by points A and B in the Mohr circle.
4. Let us now consider the case when the vertical stress remains constant while the horizontal stress is decreased.
5. The point A shifts to position A' and the diameter of the Mohr circle increases.

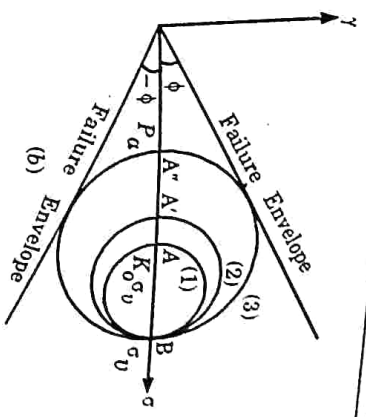
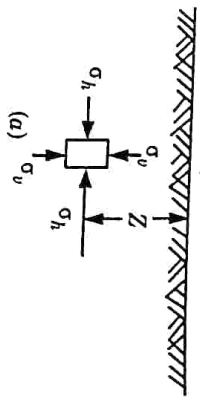

Fig. 5.2.1.

6. In the limiting condition, the point shifts to position A' when the Mohr circle touches the failure envelope.
7. The soil is at the verge of shear failure. It has attained the Rankine active state of plastic equilibrium. The horizontal stress at that state is the active pressure (P_a).

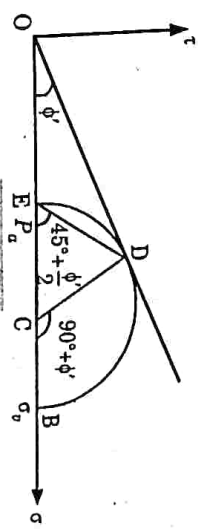

Fig. 5.2.2.

8. Fig. 5.2.2 shows the Mohr circle when active conditions are developed. Point E represents the active condition.
9. From Fig. 5.2.2,

As

$$P_a = OE = OC - CE$$

$$CE = CD = OC \sin \phi'$$

$$P_a = OC - OC \sin \phi' \quad \dots(5.2.1)$$

$$P_a = OC(1 - \sin \phi')$$

$$\sigma_v = OB = OC + CB = OC + OC \sin \phi'$$

$$\sigma_v = OC(1 + \sin \phi') \quad \dots(5.2.2)$$

10. Also,

11. From eq. (5.2.1) and (5.2.2), we get

$$K_a = \frac{1 - \sin \phi'}{1 + \sin \phi'} = \tan^2 \left(45^\circ - \frac{\phi'}{2} \right)$$

$$P_a = \left(\frac{1 - \sin \phi'}{1 + \sin \phi'} \right) \sigma_v \quad [\because \sigma_v = \gamma Z]$$

$$P_a = K_a \gamma Z \quad \dots(5.2.3)$$

where, K_a = Coefficient of active earth pressure.

12. Eq. (5.2.3) can be used to determine the active earth pressure on the retaining wall.

Que 5.3. For a clay backfill behind a retaining wall, what is the depth of tension crack? How is the total active earth pressure calculated?

An excavation was made in saturated soft clay ($\phi_u = 0$), with its sides more or less vertical. When the excavation reached 6 m, the sides caved in. What was the approximate value of cohesion of the clay soil? Take unit weight of clay = 20 kN/m³.

Answer

A. Active Case :

1. Fig. 5.3.1 shows the Mohr circle in which point B indicates the vertical stress and point E shows the active pressure.
2. The failure envelope is tangential to the circle.
3. The relationship between P_a and σ_a can be obtained as under.

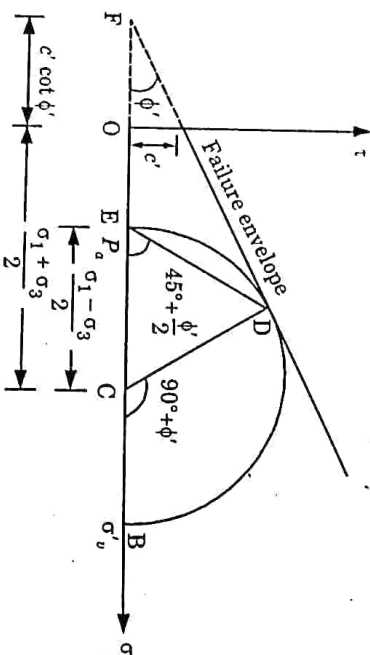

Fig. 5.3.1.

$$\sin \phi' = \frac{CD}{FO + OC}$$

$$\sin \phi' = \frac{c' \cot \phi' + (\sigma_1 - \sigma_3)/2}{(\sigma_1 + \sigma_3)/2}$$

$$\frac{(\sigma_1 - \sigma_3)}{2} = \frac{(\sigma_1 + \sigma_3)}{2} \sin \phi' + c' \cos \phi'$$

$$\frac{\sigma_1}{2} (1 - \sin \phi') = \frac{\sigma_3}{2} (1 + \sin \phi') + c' \cos \phi'$$

$$\sigma_3 = \frac{1 - \sin \phi'}{1 + \sin \phi'} \sigma_1 - \frac{2c' \cos \phi'}{1 + \sin \phi'} \quad \dots(5.3.1)$$

$$\sigma_3 = \sigma_1 \tan^2(45^\circ - \phi'/2) - 2c' \tan(45^\circ - \phi'/2)$$

4. As σ_3 is equal to the active pressure (P_a) and σ_1 is equal to the vertical stress ($\sigma_v = \gamma Z$), eq. (5.3.1) becomes

$$P_a = \left(\frac{1 - \sin \phi'}{1 + \sin \phi'} \right) \gamma Z - \frac{2c' \cos \phi'}{1 + \sin \phi'}$$

$$P_a = K_a \gamma Z - 2c' \sqrt{K_a} \quad \dots(5.3.2)$$

where,

$$K_a = \frac{1 - \sin \phi'}{1 + \sin \phi'} = \tan^2(45^\circ - \phi'/2)$$

$$\frac{\cos \phi'}{1 + \sin \phi'} = \tan(45^\circ - \phi'/2)$$

5. Eq. (5.3.2) indicates that at $Z = 0$, the active pressure is given by,

$$P_a = -2c' \sqrt{K_a}$$

6. The negative sign shows that the pressure is negative, i.e., it tries to cause a pull on the wall.

7. This tensile stress decreases with an increase in depth, and it becomes zero at a depth Z_c , given by

$$0 = K_a \gamma Z_c - 2c' \sqrt{K_a}$$

or

$$Z_c = \frac{2c'}{\gamma \sqrt{K_a}}$$

8. The depth Z_c is known as the depth of tensile crack and the depth for which the total net pressure is zero, is equal to $2Z_c$ or $\frac{4c'}{\gamma \sqrt{K_a}}$.

9. Total active earth pressure at the depth H is given by,

$$P_a = K_a \gamma H - 2c' \sqrt{K_a}$$

Numerical :

Given : Depth of excavation = 6 m; Unit weight of clay = 20 kN/m³

To Find : Value of cohesion.

1. Critical depth of cut in a ($\phi_u = 0$) soil is, therefore, equal to $\frac{4c_u}{\gamma}$ since

$$K_a = 1 \text{ for } \phi_u = 0.$$

- 2.
- $$\frac{4c_u}{\gamma} = 6$$

Cohesion,

$$c_u = \frac{6 \times 20}{4} = 30 \text{ kN/m}^2$$

Que 5.4

A retaining wall with a smooth vertical back face has to retain a backfill of $c - \phi$ soil up to 6 m above ground level. The surface of the backfill is horizontal and it has the following properties :

$\gamma = 1.9 \text{ t/m}^3$, $c = 1.7 \text{ t/m}^2$ and $\phi = 15^\circ$.

- i. Plot the distribution of active earth pressure on the wall.
- ii. Determine the magnitude and point of application of active thrust.
- iii. Determine the depth of the zone of tension cracks.

Answer

Given : $Z = 6 \text{ m}$, $\gamma = 1.9 \text{ t/m}^3$, $c = 1.7 \text{ t/m}^2$, $\phi = 15^\circ$

To Find : Active earth pressure curve, Magnitude of active thrust, and Depth of tension crack.

1. Unit weight of soil, $\gamma = 1.9 \times 9.81 = 18.64 \text{ kN/m}^3$
Cohesion, $c = 1.7 \times 9.81 = 16.68 \text{ kN/m}^2$
2. Coefficient of active earth pressure,
$$K_a = \frac{1 - \sin \phi}{1 + \sin \phi} = \frac{1 - \sin 15^\circ}{1 + \sin 15^\circ} = 0.59$$
3. At bottom, $Z = 6$
Earth pressure, $P_a = K_a \gamma Z - 2c \sqrt{K_a}$
$$P_a = 0.59 \times 18.64 \times 6 - 2 \times 16.68 \sqrt{0.59}$$

$$P_a = 40.36 \text{ kN/m}^2$$

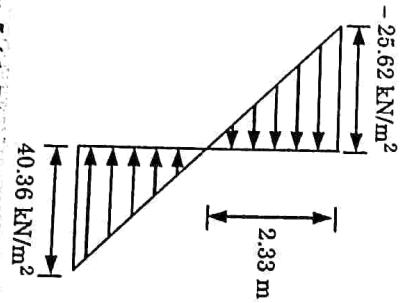

Fig. 5.4.1. Pressure distribution diagram.

4. At top,

$$Z = 0$$

$$P_a = -2c \sqrt{K_a}$$

$$P_a = -2 \times 16.68 \sqrt{0.59} = -25.62 \text{ kN/m}^2$$

5. Depth of zone of tension crack,

$$Z_c = \frac{2c}{\gamma \sqrt{K_a}} = \frac{2 \times 16.68}{18.64 \sqrt{0.59}} = 2.33 \text{ m}$$

Que 5.5

What are the various assumptions in Coulomb's theory? Also, explain Coulomb's wedge theory.

Answer

A Assumptions : Following are the basic assumptions of the Coulomb's theory or wedge theory :

1. The backfill is dry and cohesionless.
2. Soil is homogenous, isotropic, and semi-infinite.
3. The back of the wall in contact with the backfill may be inclined or vertical and is rough.
4. The failure wedge acts as rigid body and stresses are uniformly distributed over it.
5. Failure is two dimensional and rupture surface is plane which passes through the heel of the wall.
6. Location and direction of resultant thrust is known.

B. Coulomb's Wedge Theory :

1. Coulomb developed a method for the determination of the earth pressure in which he considered the equilibrium of the sliding wedge which is formed when the movement of the retaining wall takes place.
2. In the active case, the sliding wedge moves downward and outward relative to the backfill, whereas in the passive case, the sliding wedge moves upwards.
3. The lateral pressure on the wall is equal and opposite to the reactive force exerted by the wall in order to keep the sliding wedge in equilibrium.
4. In Coulomb's theory, a plane failure surface is assumed and the lateral force required to maintain the equilibrium of the wedge is found using the principles of statics.

- The procedure is repeated on several trial surfaces.
- The trial surface which gives the largest force for the active case, and the smallest force for the passive case, is the actual failure surface.
- The Coulomb's theory is more general than the Rankine's theory.

Que 5.6 Discuss Coulomb's method for determination of passive earth pressure for cohesionless soils.

Answer

- The failure surface in Coulomb's passive state is assumed to be a plane.
- In this case, the failure wedge moves upward.
- The direction of R and P_p which oppose the movement are also shown in Fig. 5.6.1(b).
- The reaction R acts at ϕ' to the normal in the downward direction and the reaction pressure P_p acts at an angle to the normal in the downward direction.
- The value of P_p is determined from triangle shown in the Fig. 5.6.1(b).
- The procedure is repeated after assuming a new trial failure surface.
- The minimum value of P_p is the Coulomb passive pressure.
- Coulomb passive pressure is given by,

$$P_p = \frac{1}{2} \gamma Z^2 K_p$$

where,

$$K_p = \frac{\sin^2(\beta - \phi')}{\sin^2 \beta \sin(\beta + \delta) \left[1 - \frac{\sin(\phi' + \delta) \sin(\phi' + i)}{\sin(\beta + \delta) \sin(\beta + i)} \right]^2}$$

- The resultant passive pressure P_p acts at a height of $Z/3$ measured from the bottom of the wall and would be inclined at angle δ to the normal, as shown in Fig. 5.6.1(a).
- However, when the retaining wall moves up relative to the soil, the friction angle δ is measured below the normal and δ is said to be negative.
- The negative wall friction produces a value of passive pressure lower than that for the usual positive wall friction.

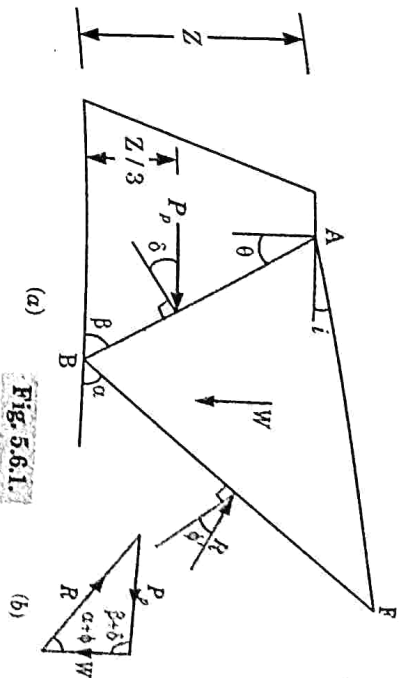

Fig. 5.6.1.

Que 5.7. Compare Coulomb's theory and Rankine's theory.

Answer

S.No.	Coulomb's Theory	Rankine's Theory
1.	Coulomb considers a retaining wall and the backfill as a system.	Rankine does not consider it.
2.	The back of the wall can be inclined or vertical.	The retaining wall is vertical.
3.	Back of retaining wall is rough.	Back of retaining wall is smooth.
4.	The backfill surface may plane or curved.	This theory allows only for a plane surface.
5.	More versatile.	Less versatile.
6.	More rational and difficult to solve the problems.	Relatively simple and hence is more commonly used.
7.	Pressure magnitude and location are calculated from the concept of wall friction.	Pressure magnitude and location are calculated mathematically.

Que 5.8. How Culmann's graphical method is convenient for determining the active earth pressure for soils having no cohesion?

Discuss all the steps of this method.

Answer
Culmann's Graphical Method :

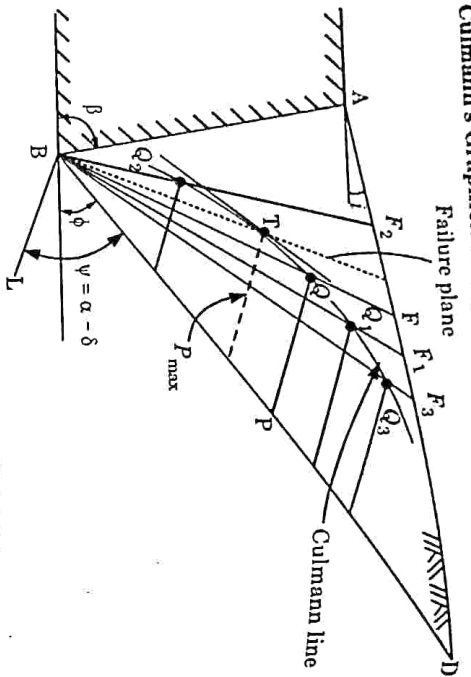

Fig. 5.8.1. Culmann's graphical method.

1. Rehmann's construction becomes inconvenient when the slope angle α approaches the angle ϕ . Culmann developed a method which is more general than Rehmann's method.
 2. Culmann's method is convenient for determining the active earth pressure for soils having no cohesion. Most backfills, in practice, fall into this category.
 3. The method can be used for backfill surfaces of any shape, different types of surcharge loads and even for layered backfill.
- The Procedure Consists of the Following Steps :**
1. Draw the retaining wall AB to the scale.
 2. Draw the ϕ -line BD .
 3. A line BL is drawn at an angle ψ with line BD , such that $\psi = \alpha - \delta$.
 4. A failure surface BF is assumed, and the weight (W) of failure wedge ABF is computed.
 5. The weight (W) is plotted along BD such that $BP = W$.
 6. A line PQ is drawn from point P parallel to BL to intersect the surface BF at Q .
 7. The length PQ represents the magnitude of P_a required to maintain equilibrium for assumed failure plane.
 8. Several other failure planes BF_2, BF_1, BF_3 etc., are assumed and the procedure is repeated. Thus, the point Q_2, Q_1, Q_3 etc., are obtained.
 9. A smooth curve is drawn joining points Q_2, Q_1, Q_3 etc. The curve is called Culmann's line.

10. A line (shown dotted) is drawn tangential to the Culmann line and parallel to BD . Point T is the point of tangency.
11. The magnitude of the largest value (P_{max}) of P_a is measured from the tangent point T to the line BD and parallel to BL . It is equal to Coulomb's pressure (P_a).
12. The actual failure plane passes through the point T (shown dotted).

Que 5.9. Using the Rankine theory, determine the total active thrust on a vertical retaining wall 10 m high if the soil retained has the following properties $\phi = 35^\circ$; $\gamma = 19 \text{ kN/m}^3$. What is the increase in horizontal thrust if the soil slopes up from the top of the wall at an angle of 35° to the horizontal?

AKTU 2015-16, Marks 10

AKTU 2018-19, Marks 07

Answer

Given : Height of wall, $Z = 10 \text{ m}$, Angle of friction, $\phi = 35^\circ$
 Unit weight of soil, $\gamma = 19 \text{ kN/m}^3$, Slope of soil surface, $\beta = 35^\circ$
To Find : Increase in horizontal thrust.

1. The coefficient of active earth pressure (K_a) is given by,

$$K_a = \frac{1 - \sin \phi}{1 + \sin \phi} = \frac{1 - \sin 35^\circ}{1 + \sin 35^\circ} = 0.271$$

2. The lateral active earth pressure,

$$P_a = (1/2) K_a \gamma Z^2 = (1/2) \times 0.271 \times 19 \times 10^2 = 257.45 \text{ kN}$$

3. Now,

$$K_a = \cos \beta \times \frac{\cos \beta - \sqrt{\cos^2 \beta - \cos^2 \phi}}{\cos \beta + \sqrt{\cos^2 \beta - \cos^2 \phi}}$$

$$= \cos 35^\circ \times \frac{\cos 35^\circ - \sqrt{\cos^2 35^\circ - \cos^2 35^\circ}}{\cos 35^\circ + \sqrt{\cos^2 35^\circ - \cos^2 35^\circ}}$$

$$K_a = 0.819 \times \frac{0.819 - \sqrt{0.671 - 0.671}}{0.819 + \sqrt{0.671 - 0.671}} = 0.819$$

4. Hence, $P_a = (1/2) K_a \gamma Z^2 = (1/2) \times 0.819 \times 19 \times 10^2 = 778.05 \text{ kN}$
5. Increase in horizontal thrust = $778.05 - 257.45 = 520.6 \text{ kN}$

PART-2

Stability of Slopes : Finite and Infinite Slopes, Types of Slope Failure, Culmann's Method and Method of Slices, Stability Number and Chart, Bishop's Method.

Questions-Answers
Long Answer Type and Medium Answer Type Questions

Que 5.10. Explain the types of slopes of earth surface.

Answer

Types of slopes :

A. On the basis of method of construction:

1. **Natural Slopes :**
 - i. The slopes formed due to natural process and exist naturally are called natural slopes.
 - ii. Natural slopes are those that exist in nature and are formed by natural causes. Such slopes exist in hilly areas.
2. **Artificial Slopes :**
 - i. The slopes formed by unnatural process. Artificial slopes are formed by humans as per requirements.
 - ii. The sides of cuttings, the slopes of embankments constructed for roads, railway lines, canals etc., and the slopes of earth dams constructed for storing water are examples of manmade slopes.

B. On the Basis of Type of Soil :

1. **Cohesive Soil Slope :** Having purely cohesive soil as its content. It is also known as cohesive soil slope.
2. **Frictional Soil Slope :** Slopes having frictional soil as its contents. It is also known as frictional soil slope.
3. **Cohesive-Frictional Soil Slope :** Slopes made up of soil which has both frictional as well as cohesive properties. It is also known as c- ϕ soil slope.

Que 5.11. What are the assumptions made in slope stability analysis ?

Answer

Assumptions made in Slope Stability Analysis :

1. The problem is treated as two dimensional, i.e., no shear stresses are assumed to be existing across the plane of cross-section of the embankment.
2. The shear strength of the soil is known, and can be expressed in terms of Coulomb's law, i.e.,
$$\tau_f = c + \sigma' \tan \phi$$

where, c and ϕ represent the average effective values of cohesion and angle of friction, respectively, of the homogeneous embanked soil.

3. When different soils are used in the construction of the embankment, such as in a non-homogeneous zoned embankment, the material in each zone is represented by a different Coulomb's equation for shear strength, using c and ϕ values of the respective zone.

If any water is seeping through the embankment, causing additional disturbing forces, then it is assumed that the flownet for the seepage is already known, so that the seepage stresses can be evaluated.

With these assumptions, we can analyse and examine the stability of earthen slopes with a fair degree of accuracy.

Que 5.12. What do you mean by finite slope? Derive the expression for factor of safety and shear strength during the stability analysis.

Answer

A. Finite Slopes :

1. A finite slope is one with a base and top surface, the height being limited. The inclined faces of earth dams, embankments and excavation and the like are all finite slopes.
2. These slopes are bounded by top and bottom surface.
3. Failure of finite slopes takes place due to rotation.

B. Factor of Safety :

1. Factor of safety of a slope is defined as the ratio of average shear strength (s) of a soil to the average shear stress (τ_d) developed along the potential failure surface.

$$F_s = s / \tau_d$$

where, F_s = Factor of safety.

s = Average shear strength of the soil.

τ_d = Average shear stress developed along the potential surface.

2. **Shear Strength :** Shear strength of a soil is given by,

$$s = c + \sigma \tan \phi$$

where, c = Cohesion.

ϕ = Angle of internal friction.

σ = Normal stress on the potential failure surface.

Similarly, the mobilized shear strength is given by,

$$\tau_d = c_d + \sigma \tan \phi_d$$

where, c_d and ϕ_d are the cohesion and angle of internal friction that develop along the potential failure surface.

$$F_s = \frac{c + \sigma \tan \phi}{c_d + \sigma \tan \phi_d}$$

3. Factor of safety wrt cohesion is, $F_c = \frac{c}{c_d}$ (\because For cohesive soil, $\phi = 0$)

4. Factor of safety wrt angle of internal friction, $F_\phi = \frac{\tan \phi}{\tan \phi_d}$

5. Then, $F_s = F_c = F_\phi$
When, $F_s = 1$, then the slope is said to be in a state of failure.

Que 5.13. What do you mean by infinite slope? Describe the stability analysis of cohesionless soil in infinite slope.

Answer

A. Infinite Slope:

1. Any slope of grade extends with uniform soil condition at any given depth below the surface is known as infinite slope.
2. The strata of different soils are parallel to the surface of slope.
3. Failure of infinite slope takes place due to sliding and failure plane is planer and parallel to ground surface.

B. Stability Analysis of Cohesionless Soil in Infinite Slope:

1. Let, AB represents infinite slope having slope angle, i with horizontal. Failure of which takes along the critical section CD (It means parallel to ground surface) and failure is at Z depth from surface.

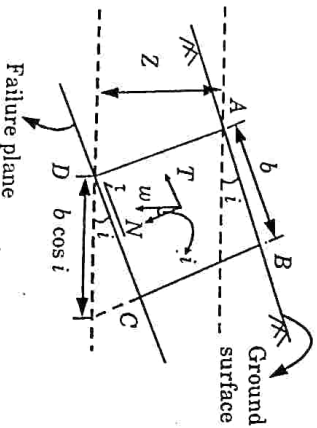

Fig. 5.13.1.

2. Area of wedge ABCD = $Z \times (b \cos i)$
3. Volume of wedge ABCD = $Z (b \cos i) \times 1$
4. Weight of wedge ABCD, $w = Z (b \cos i) \times \gamma$
5. Normal component of w , $N = w \cos i$

$$N = Z (b \cos i) \gamma \times \cos i$$

$$N = Z (b \cos^2 i) \gamma$$

6. Tangential component of w , $T = w \sin i$

$$T = Z (b \cos i) \gamma \times \sin i$$

$$T = Z (b \cos i \sin i) \gamma$$

7. Normal stress, $\sigma = \frac{N}{\text{Area}} = \frac{Z(b \cos^2 i) \gamma}{(b \times 1)}$

$$\sigma = Z (\cos^2 i) \gamma \quad \dots(5.13.1)$$

8. Tangential stress or shear stress, $\tau = T/\text{Area}$

$$\tau = \frac{Z(b \cos i \sin i) \gamma}{(b \times 1)}$$

$$\tau = Z (\cos i \sin i) \gamma \quad \dots(5.13.2)$$

9. If pore water is present, then normal pore water pressure

$$= Z (\cos^2 i) \gamma_w$$

10. Factor of Safety for Different Conditions of Cohesionless Soil:

i. **Dry or Moist Soil:** Factor of safety with respect to shear strength,

$$F_s = s/\tau$$

$$s = c + \sigma \tan \phi$$

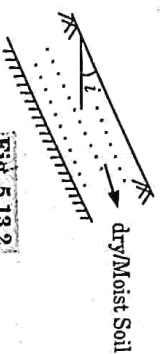

Fig. 5.13.2.

For cohesionless soil, $c = 0$

$$s = \sigma \tan \phi = Z (\cos^2 i) \gamma \tan \phi \quad [\text{from eq. (5.13.1)}]$$

$$\tau = Z (\cos i \sin i) \gamma \quad [\text{from eq. (5.13.2)}]$$

$$F_s = \frac{Z(\cos^2 i) \gamma \tan \phi}{Z(\cos i \sin i) \gamma} = \frac{\cos i \tan \phi}{\sin i}$$

$$F_s = \frac{\tan \phi}{\tan i}$$

ii. **Submerged Soil:**

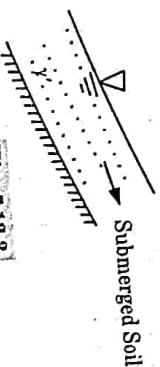

Fig. 5.13.3.

where,

$$\bar{\sigma} = \gamma' Z \cos^2 i$$

$$\tau = \gamma' Z \cos i \sin i$$

γ' = Unit weight of submerged soil.

$$F_S = \frac{c + \bar{\sigma} \tan \phi}{\tau} = \frac{0 + (\gamma' Z \cos^2 i) \tan \phi}{\gamma' Z \cos i \sin i} \quad (\because c = 0)$$

$$F_S = \frac{\tan \phi}{\tan i}$$

11. For safety or no failure, $F_S \geq 1$

or

$$F_S = \frac{\tan \phi}{\tan i} \geq 1 \Rightarrow \tan \phi \geq \tan i$$

$\phi \geq i$, for stability.

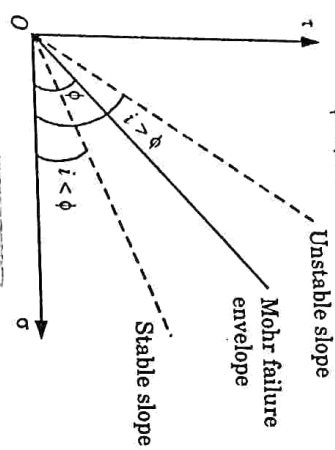

Fig. 5.13.4.

Note : Maximum angle in case of infinite slope in cohesionless soil should be less than internal friction.

Que 5.14. What are the different types of slope failures ?

Answer

Following are the various types of slope failures :

1. Rotational Failure :

- i This type of failure occurs by rotation along a slip surface by downward and outward movement of the soil mass, as shown in Fig. 5.14.1.
- ii The slip surface is generally circular for homogeneous soil conditions and non-circular in case of non-homogeneous soil conditions.

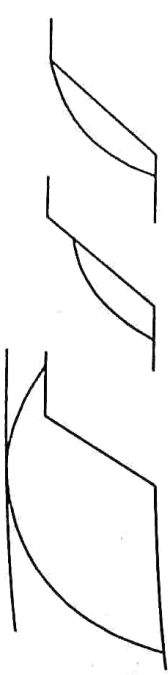

(a) Toe failure (b) Slope failure (c) Base failure

Fig. 5.14.1. Rotational failure.

Translational Failure :

- 2 A constant slope of unlimited extent and having uniform soil properties at the same depth below the free surface is known as an infinite slope.

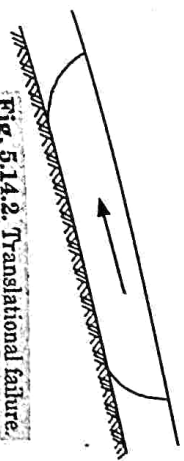

Fig. 5.14.2. Translational failure.

- ii Translational failure occurs in an infinite slope along a long failure surface parallel to the slope, as shown in Fig. 5.14.2.

3. Compound Failure :

- i A compound failure is a combination of the rotational slips and the translational slip, as shown in Fig. 5.14.3.
- ii A compound failure surface is curved at the two ends and plane in the middle portion.



Fig. 5.14.3. Compound failure.

- 4. Wedge Failure : A failure along an inclined plane is known as plane failure or wedge failure or block failure, as shown in Fig. 5.14.4. It occurs when distinct blocks and wedges of the soil mass become separated.

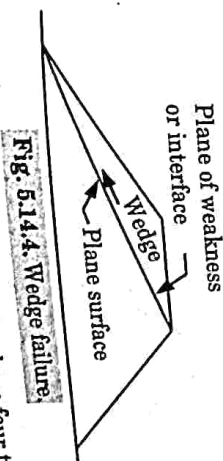

Fig. 5.14.4. Wedge failure.

- 5. Miscellaneous Failures : In addition to above four types of failures, some complex types of failures in the form of spreads and flows may also occur.

Que 5.15. What are the different factors of safety used in stability of slopes ?

Answer

Following are the three different factors of safety :

- Factor of Safety with respect to Shear Strength :**
The factor of safety is defined as the ratio of the shear strength to the shear stress along the surface of failure.

$$F_s = \frac{s}{\tau_m}$$

Thus F_s = Factor of safety with respect to shear strength.

where, s = Shear strength.

τ_m = Mobilized shear stress (equal to applied shear stress).

- Factor of Safety with respect to Cohesion :** The factor of safety with respect to cohesion (F_c) is the ratio of the available cohesion intercept (c) and the mobilized cohesion intercept (c_m).

$$F_c = \frac{c}{c_m}$$

where, c = Cohesion intercept.

c_m = Mobilized cohesion intercept.

F_c = Factor of safety with respect to cohesion.

- Factor of Safety with respect to Friction :** The factor of safety with respect to friction is the ratio of the available frictional strength to the mobilized frictional strength. Thus

$$F_\phi = \frac{\bar{\sigma} \tan \phi}{\bar{\sigma} \tan \phi_m} = \frac{\tan \phi}{\tan \phi_m}$$

where,

F_ϕ = Factor of safety with respect to friction.

ϕ = Angle of shearing resistance.

ϕ_m = Angle of mobilized shearing resistance.

Que 5.16. Describe the Culmann's method for approximate stability analysis of homogeneous slopes.

Answer

Culmann's Method :

- Culmann's method is used for the approximate stability analysis of homogeneous slopes.
- A plane failure surface passing through the toe is assumed. A plane failure surface is not a correct assumption for a homogeneous soil.

Derivation :

- Let us consider the equilibrium of the triangular wedge ABD formed by the assumed failure surface AB as shown in Fig. 5.16.1. The wedge is in equilibrium under the three forces :

- Weight of the wedge (W).
- Cohesive force (c) along the surface AB .
- The reaction R is inclined at angle ϕ_m to the normal.

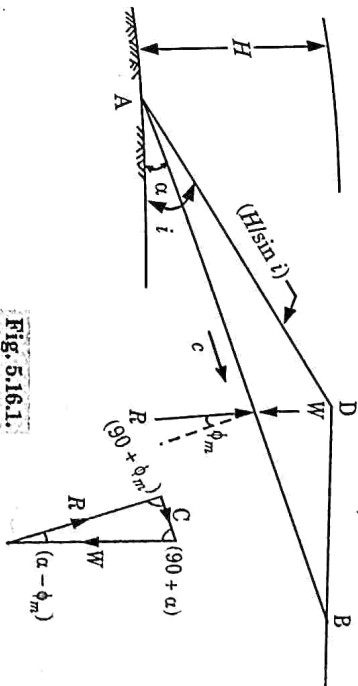

Fig. 5.16.1.

- The triangle of forces is also shown in Fig. 5.16.1. The magnitude and direction of W and c are known. The direction of R is also known. The weight of the wedge is given by,

$$W = \frac{1}{2} \gamma L \left(\frac{H}{\sin i} \right) \sin(i - \alpha) \quad \dots(5.16.1)$$

and

$$c = c_m L \quad \dots(5.16.2)$$

where, H = Height of slope.

c_m = Mobilised cohesion.

ϕ_m = Angle of mobilized friction.

L = Length of failure surface AB .

Note : Area of a triangle $ABD = \frac{1}{2} d b \sin A$

where d and b are the length of sides BA and AD , respectively.

- From the law of sines,

$$\frac{c}{W} = \frac{\sin(\alpha - \phi_m)}{\sin(\phi_m + 90^\circ)} = \frac{\sin(\alpha - \phi_m)}{\cos \phi_m} \quad \dots(5.16.3)$$

- Substituting the values of W and c from eq. (5.16.1) and eq. (5.16.2) in eq. (5.16.3), we get

$$\frac{c_m L}{(1/2) \gamma L (H / \sin i) \sin(i - \alpha)} = \frac{\sin(\alpha - \phi_m)}{\cos \phi_m}$$

$$\left(\frac{c_m}{\gamma H} \right) = \frac{1}{2} \operatorname{cosec} i \sin(i - \alpha) \sin(\alpha - \phi_m) \sec \phi_m \quad \dots(5.16.4)$$

5. The left-hand side of eq. (5.16.4) is known as the stability number (S_n). The most dangerous plane is that for which the angle α is such that the stability number becomes a maximum, i.e.,

$$\frac{d(S_n)}{d\alpha} = 0$$

$$\frac{d}{d\alpha} [\sin(i-\alpha) \sin(\alpha-\phi_m)] = 0$$

$$\sin(i-\alpha) \cos(\alpha-\phi_m) - \sin(\alpha-\phi_m) \cos(i-\alpha) = 0$$

$$\tan(i-\alpha) = \tan(\alpha-\phi_m)$$

$$i-\alpha = \alpha-\phi_m$$

$$\alpha_c = \frac{i+\phi_m}{2} \quad \dots(5.16.5)$$

where α_c is the critical slope angle.

6. Taking the value of α_c from eq. (5.16.5) put in eq. (5.16.4), we get

$$\left(\frac{C_m}{\gamma H}\right)_{\max} = \frac{1}{2} \operatorname{cosec} i \sec \phi_m \left[\sin \left\{ i - \left(\frac{i+\phi_m}{2} \right) \right\} \right] \times \left[\sin \left\{ \left(\frac{i+\phi_m}{2} \right) - \phi_m \right\} \right]$$

$$= \frac{1}{2} \operatorname{cosec} i \sec \phi_m \sin \left(\frac{i-\phi_m}{2} \right) \sin \left(\frac{i-\phi_m}{2} \right)$$

$$= \frac{1}{2} \operatorname{cosec} i \sec \phi_m \left[\frac{1 - \cos(i-\phi_m)}{2} \right]$$

$$\left(\frac{C_m}{\gamma H}\right)_{\max} = \frac{1 - \cos(i-\phi_m)}{(4 \sin i \cos \phi_m)} \quad \dots(5.16.6)$$

$$H = \frac{4 C_m \sin i \cos \phi_m}{\gamma [1 - \cos(i-\phi_m)]} \quad \dots(5.16.7)$$

where H is the safe height of slope.

7. The Culmann method gives reasonably accurate results for homogeneous slopes which are vertical or nearly vertical.
 8. The critical surface for general slopes is not a plane and, therefore, the critical slope α_c has little practical use for such slopes.

Que 5.17. Derive an expression for the factor of safety by using Swedish Circle method.

OR

How a slope is analyzed using Swedish Circle method? Derive an expression for the factor of safety.

AKTU 2019-20, Marks 07

Answer

1. In this method, the soil mass above the assumed slip circle is divided into a number of vertical slices of equal width, as shown in Fig. 5.17.1. The number of slices may vary from 6 to 12, when hand computations are to be used.

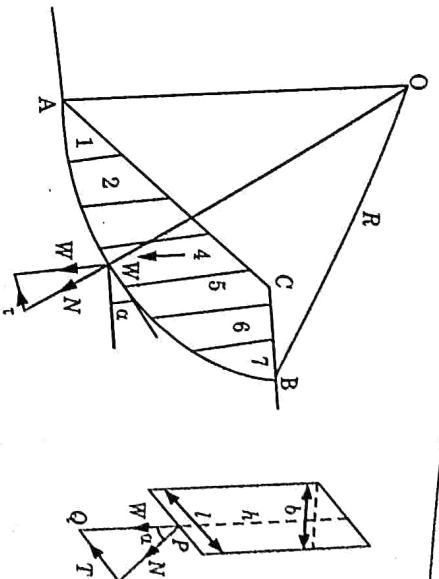

Fig. 5.17.1. c - ϕ analysis method of slices.

2. In the conventional method, the forces between the slices are neglected and each slice is considered to be an independent column of soil of unit thickness.
 3. If slice number 4 is taken as a typical slice, the weight of the slice W is calculated as equal to γhb .
 where,
 γ = Bulk unit weight of the soil.
 h = Height of the slice.
 b = Width of slice.
 4. The line of action which can be taken to pass through the mid-width point of the slice, meets the base of the slice of length l at P .
 5. The weight W is plotted as a vector PQ and then resolved into its normal and tangential components N and T , respectively, at P .
 6. Since the normal component N passes through P and the centre of rotation O , it does not have a driving moment, but mobilize frictional resistance along the slip surface.
 7. The tangential component T causes the rotating moment. In the end slice, such as slice number 1 in Fig. 5.17.1, the tangential component may act in an opposite direction, causing a restoring moment.
 8. T is taken as positive when causing a driving moment and negative when causing a resisting moment.
 9. The algebraic sum of T will always be positive and contribute to the driving moment.
 10. Considering the whole slip surface AB of length L , the total driving and resisting forces are:
 i. Driving forces = ΣT
 ii. Resisting force = $\Sigma c'l + \Sigma N \tan \phi' = c'l + \Sigma N \tan \phi'$

iii. Driving moment = $\Sigma T R$

iv. Resisting moment = $c'L R + \Sigma N \tan \phi' R$

v. The factor of safety against sliding, F is written as :

$$F = \frac{c'L + \Sigma N \tan \phi'}{\Sigma T} \dots(5.17.1)$$

Since $N = W \cos \alpha$ and $T = W \sin \alpha$, eq. (5.17.1) can also be written in the form

$$F = \frac{c'L + \tan \phi' \Sigma W \cos \alpha}{\Sigma W \sin \alpha} \dots(5.17.2)$$

11. The method of slices can be used for homogeneous or stratified soil and can be used where seepage is taking place and pore pressure are present in the soil.

Que 5.18. Fig. 5.18.1 shows a trial slip surface through a soil mass ($c = 30 \text{ kN/m}^2$, $\phi = 30^\circ$, $\gamma = 25 \text{ kN/m}^3$). Determine the factor of safety using Swedish Circle method.

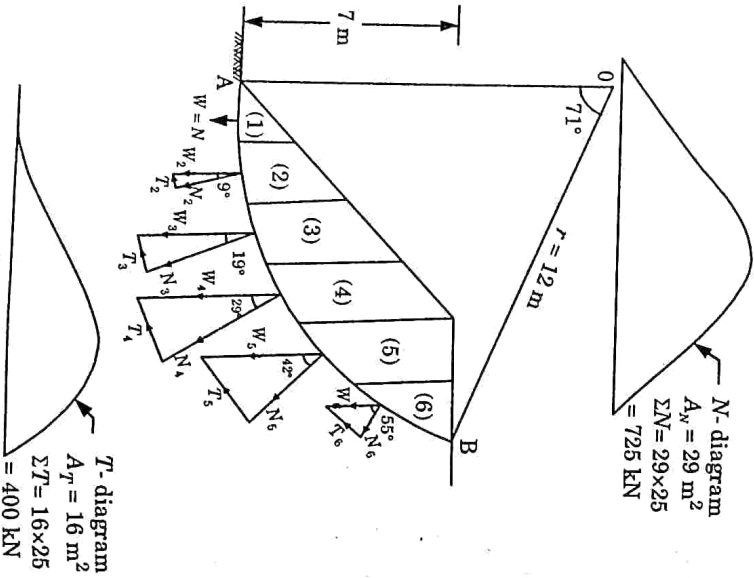

Fig. 5.18.1.

Answer

Given : Cohesion, $c = 30 \text{ kN/m}^2$, Angle of resistance, $\phi = 30^\circ$
 Unit weight of soil mass, $\gamma = 25 \text{ kN/m}^3$
To Find : Factor of safety.

1. The sliding wedge is divided into 6 critical slices of equal width of 2 m, the calculations are shown in tabular form below.

Slice No.	Weight (W)				α	$T = W \sin \alpha$ (kN)	$N = W \cos \alpha$ (kN)
	Average Ordinate (m)	Width (m)	Volume m^3	Weight W (kN)			
1	0.9	2	1.8	45	0	0	45
2	2.4	2	4.8	120	9°	18.77	118.52
3	3.6	2	7.2	180	19°	58.60	170.20
4	4.5	2	9.0	225	29°	109.08	196.79
5	4.0	2	8.0	200	42°	133.83	148.83
6	1.80	2	3.6	90	55°	73.72	51.62
						$\Sigma T = 394$	$\Sigma N = 730.75$

2. Length of arc,

$$L_a = \left(\frac{2\pi \times 12}{360^\circ} \right) \times 71^\circ = 14.87 \text{ m}$$

3. Factor of safety, $F_s = \frac{cL_a + \tan \phi \Sigma N}{\Sigma T} = \frac{30 \times 14.86 + \tan 30^\circ \times 730.76}{394}$

$$F_s = 2.2$$

Que 5.19. What is stability number? Discuss the uses of stability charts.

Answer

A. Stability Numbers :

1. This dimensionless number is proportional to the required cohesion and is inversely proportional to the allowable height.

$$S_n = \frac{c_m}{\gamma H} = \frac{c}{F_s \gamma H} \dots(5.19.1)$$

2. The reciprocal of the stability number is known as stability factor.

3. Taylor determined the values of S_n for finite slopes using the friction circle method.

4. The charts are prepared indicating the stability number, and slope angle i for various values of ϕ_m , as shown in Fig. 5.19.1.

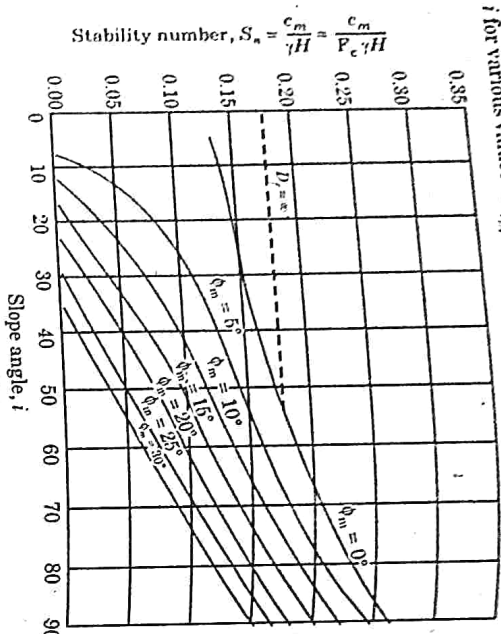

Fig. 5.19.1.

5. There are 5 parameters, viz c_m , γ , H , i and ϕ_m . However, if $\phi_m = 0$ (purely cohesive soils), a sixth parameter D_f becomes also important, as shown in Fig. 5.19.1.

$$D_f = \frac{\text{Depth of hard stratum below the top of the slope}}{\text{Height of slope}}$$

B. Uses of Stability Chart :

1. The stability chart can be used to determine the factor of safety of a given slope.
2. The stability charts can be used to determine the steepest slope for a given factor of safety. In this case, the stability number is computed from the relation.

$$S_n = \frac{c}{F_s \cdot H}$$

For the computed value of S_n , the value of i is read from the stability chart for the given value of ϕ_m .

Que 5.20. A 10 m high cutting has a slope of 40° to horizontal, the soil was tested and its cohesion, void ratio and angle ϕ were found to be 2.5 t/m^2 , 0.81 and 14° respectively. Determine the FOS with respect to cohesion against failure of the slope. When water level rises upto the full height :

Given : $G = 2.7$ & for 40° slope values of stability number for different values of ϕ

ϕ	S_n
6°	0.122
7°	0.116
14°	0.074

Answer

Given : Cohesion, $c = 2.5 \text{ t/m}^2 = 25 \text{ kN/m}^2$, Void ratio, $e = 0.81$

Angle of slope, $i = 40^\circ$, Height of slope, $H = 10 \text{ m}$, $\phi = 14^\circ$

To Find : Factor of safety w.r.t. cohesion against slope failure.

1. Saturated unit weight of soil,

$$\gamma_{\text{sat}} = \frac{(e + G)\gamma_w}{1 + e} = \frac{(0.81 + 2.7) \times 10}{1 + 0.81} = 19.39 \text{ kN/m}^2$$

2. Stability number, $S_n = \frac{c}{F_s \cdot H} = \frac{25}{F_s (19.39 - 10) \times 10}$

$$0.074 = \frac{25}{F_s \times 9.39 \times 10} \quad (\because \phi = 14^\circ)$$

$$F_s = 3.6$$

Que 5.21. Describe the Bishop's method for slope analysis.

Answer

Bishop's Method :

1. Equation developed based on Bishop's analysis of slopes, contains the term pore pressure u . The Bishop and Morgenstern method proposes the following equation for the evaluation of u

$$r_u = u / \gamma h \quad \dots(5.21.1)$$

Where, u = Pore water pressure at any point on the assumed failure surface.

γ = Unit weight of the soil.
 h = The depth of the point in the soil mass below the ground surface.

2. The pore pressure ratio r_u is assumed to be constant throughout the cross-section, which is called a homogeneous pore pressure distribution. Fig. 5.21.1 shows the various parameters used in the analysis.

The factor of safety F_s is defined as

$$F_s = \frac{m}{n}$$

...(5.21.2)

where,

m , n = Stability coefficients.

3. The depth factor is given by, $n_d = D/H$,

where, H = Height of slope,

D = Depth of firm stratum from the top of the slope.

4. Bishop and Morgenstern (1960) limited their charts to value of $c/\gamma H$ equal to 0.000, 0.025 and 0.050.

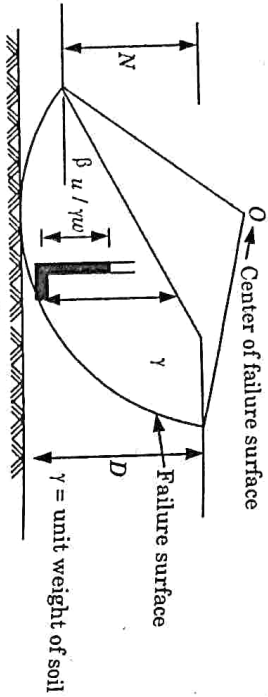

Fig. 5.21.3.

VERY IMPORTANT QUESTIONS

Following questions are very important. These questions may be asked in your SESSIONALS as well as UNIVERSITY EXAMINATION.

Q.1. What are the different types of earth pressure ? Give examples.

Ans. Refer Q. 5.1, Unit-5.

Q.2. For a clay backfill behind a retaining wall, what is the depth of tension crack ? How is the total active earth pressure calculated ? An excavation was made in saturated soft clay ($\phi_u = 0$), with its sides more or less vertical. When the excavation reached 6 m, the sides caved in. What was the approximate value of cohesion of the clay soil ? Take unit weight of clay = 20 kN/m³.

Ans. Refer Q. 5.3, Unit-5.

Q.3. A retaining wall with a smooth vertical back face has to retain a backfill of $c - \phi$ soil up to 6 m above ground level.

The surface of the backfill is horizontal and it has the following properties:

$\gamma = 1.9 \text{ t/m}^3$, $c = 1.7 \text{ t/m}^2$ and $\phi = 15^\circ$.

i. Plot the distribution of active earth pressure on the wall.

ii. Determine the magnitude and point of application of active thrust.

iii. Determine the depth of the zone of tension cracks.

Ans. Refer Q. 5.4, Unit-5.

Q.4. What are the various assumptions in Coulomb's theory ? Also, explain Coulomb's wedge theory.

Ans. Refer Q. 5.5, Unit-5.

Q.5. How Culmann's graphical method is convenient for determining the active earth pressure for soils having no cohesion ? Discuss all the steps of this method.

Ans. Refer Q. 5.8, Unit-5.

Q.6. Using the Rankine theory, determine the total active thrust on a vertical retaining wall 10 m high if the soil retained has the following properties $\phi = 35^\circ$; $\gamma = 19 \text{ kN/m}^3$. What is the increase in horizontal thrust if the soil slopes up from the top of the wall at an angle of 35° to the horizontal ?

Ans. Refer Q. 5.9, Unit-5.

Q.7. What do you mean by infinite slope ? Describe the stability analysis of cohesionless soil in infinite slope.

Ans. Refer Q. 5.13, Unit-5.

Q.8. What are the different factors of safety used in stability of slopes ?

Ans. Refer Q. 5.15, Unit-5.

Q.9. Derive an expression for the factor of safety by using Swedish Circle method.

Ans. Refer Q. 5.17, Unit-5.

Q.10. What is stability number ? Discuss the uses of stability charts.

Ans. Refer Q. 5.19, Unit-5.

Q.11. Describe the Bishop's method for slope analysis.

Ans. Refer Q. 5.21, Unit-5.



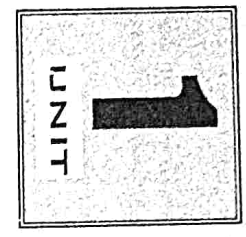

Origin and Classification of Soil (2 Marks Questions)

1.1. Define origin of soil.

AKTU 2018-19, Marks 02

- Ans:** Soils are formed by weathering of rocks and minerals at or near the earth's surface by either :
- i. Physical disintegration due to the action of natural or mechanical agents,
 - ii. Chemical decomposition due to the action of chemical agents.

1.2. Illustrate the different methods of soil formation.

Ans: Following are the two methods of soil formation :

1. **Physical Disintegration** : It is due to :
 - i. Temperature changes.
 - ii. Abrasion.
 - iii. Wedging action of ice
 - iv. Spreading of roots of plants.
2. **Chemical Decomposition** : It includes :
 - i. Hydration.
 - ii. Carbonation.
 - iii. Oxidation.
 - iv. Leaching.
 - v. Hydrolysis.

1.3. What is muck ?

AKTU 2015-16, 2017-18, Marks 02

Ans: Muck is the mixture of the fine particles and highly decomposed organic matter. It is black in colour and of extremely soft consistency.

1.4. Draw the figure of element separated soil into three phases.

AKTU 2018-19, Marks 02

Ans:

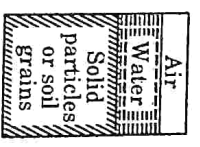

Fig. 1. Representation of soil mass by three-phase diagram.

1.5. Write methods to determine the water content.

AKTU 2017-18, Marks 02

- Ans:** Following are the methods which are used to determine the water content :
- i. Oven dry method.
 - ii. Sand bath method.
 - iii. Alcohol method.
 - iv. Calcium carbide method.
 - v. Radiation method, etc.

1.6. Define the term consistency.

Ans: Consistency is a term which is used to describe the degree of firmness of a soil in a qualitative manner by using descriptions such as soft, medium, firm, stiff or hard. It indicates the relative ease with which a soil can be deformed.

1.7. Define bulk unit weight. Write the relation between bulk unit weight and dry unit weight.

AKTU 2017-18, Marks 02

Ans: Bulk Unit Weight : It is defined as the total weight per unit total volume. Thus,

$$\gamma = \frac{W}{V}$$

It is expressed as N/m^3 or kN/m^3 .

Relation : Dry unit weight, $\gamma_d = \frac{\gamma}{1 + w}$

where, γ = Bulk unit weight.
 w = Water content.

1.8. Define Consistency limits.

AKTU 2017-18, Marks 02

Ans: Consistency Limits (Atterberg Limits) : The liquid limit, plastic limit and shrinkage limits are known as Atterberg limits. The water content at which the soil behaviour changes from the liquid to the plastic state is called the liquid limit; from the plastic to the semi-solid state is the plastic limit; and from the semi-solid to the solid state is the shrinkage limit.

1.9. What is liquid limit ?

Ans: Liquid Limit (w_L) : It is the water content at which a soil is practically in a liquid state, but has infinitesimal resistance against flow which can be measured by any standardized procedure.

1.10. Define plastic and shrinkage limit.

- Ans:**
- i. **Plastic Limit, w_p** : It is defined as the water content at which a soil would just begin to crumble when rolled into a thread of approximately 3 mm diameter.
 - ii. **Shrinkage Limit, w_s** : It is the maximum water content at which a decrease in moisture content does not cause any decrease in the volume of the soil mass. It is also the smallest value of water content at complete saturation of the soil mass.

1.11. What are the basic structural units of clay minerals ?
AKTU 2019-20, Marks 02

- Ans:** Structure of Clay Minerals : Structure of clay minerals are built of two fundamental crystal sheets :
1. Tetrahedral or silica sheet.
 2. Octahedral or Alumina sheet.

1.12. Briefly explain single grain structure.
AKTU 2015-16, Marks 02

Ans: Cohesionless soils, such as gravel and sand, are composed of bulky grains in which the gravitational forces are more predominant than surface forces. When deposition of these soils occurs, the particles settle under gravitational forces and take an equilibrium position. Each particle is in contact with those surrounding it. The soil structure so formed is known as single-grained structure.

1.13. Briefly explain the flocculant grain structure.
AKTU 2016-17, Marks 02

Ans: Flocculant structure is formed when there is a net attractive force between particles. Flocculated structure occurs in clays. The degree of flocculation of a clay deposits depends upon the type and concentration of clay particles and the presence of salts in water.

1.14. What is relative consistency ?
Ans: Relative consistency (I_c) or consistency index is defined as the ratio of the difference between the liquid limit and the natural water content of a soil to its plasticity index.

$$I_c = \frac{w_L - w_N}{I_p}$$

1.15. Explain index properties of soil.
AKTU 2019-20, Marks 02
 OR
AKTU 2016-17, Marks 02
 Define index properties of soil.

What do you understand by index properties ?
 OR

AKTU 2017-18, Marks 02

Ans: **Index Properties of Soil** : The test is carried out in order to classify a soil as termed as classification test. The numerical results obtained on the basis of such test are termed as index properties of soil. These are divided into two following categories :

1. Soil grain properties.
2. Soil aggregate properties.

1.16. Discuss plasticity index and liquidity index.

Ans:

- i. **Plasticity Index, (I_p)** : It is the range of moisture content over which a soil exhibits plasticity. It is the numerical difference between the liquid limit and the plastic limit.

$I_p = w_L - w_p$

- ii. **Liquidity Index, (I_L)** : It is defined as the ratio of the difference between the natural water content of a soil and its plastic limit to its plasticity index.

$$I_L = \frac{w_N - w_p}{I_p}$$

1.17. What is relative density or density index ?

Ans: Relative density (I_r) is defined as the ratio of the difference between the void ratio of a cohesionless soil in the loosest state and void ratio in its natural state to the difference between its void ratios in the loosest and densest states.

$$D_r \text{ or } I_r = \frac{e_{max} - e_{nat}}{e_{max} - e_{min}} \times 100\%$$

1.18. Differentiate between Activity and Sensitivity.
AKTU 2017-18, Marks 02

S.No.	Activity	Sensitivity
1.	Activity (A) of a soil is the ratio of the plasticity index and the percentage of clay fraction.	It is defined as the ratio of the undisturbed strength to remoulded strength at the same water content.
2.	It expressed as : $A = \frac{I_p}{F}$	It is expressed as : $S_r = \frac{s(\text{undisturbed})}{s(\text{remoulded})}$

1.19. Write down the expressions for coefficient of uniformity and coefficient of curvature.

Ans:

- i. Coefficient of uniformity, $C_u = \frac{D_{60}}{D_{10}}$
- ii. Coefficient of curvature, $C_c = \frac{D_{30}^2}{D_{60} \times D_{10}}$

1.20. Define flow index.

Ans:

Flow index is the slope of flow curve obtained by plotting water content as ordinate on natural scale against number of blows on log scale. It is given by,

$$I_f = \frac{w_1 - w_2}{\log_{10} N_2 / N_1}$$

where, w_1 = Water content corresponding to number of blows N_1
 w_2 = Water content corresponding to number of blows N_2

1.21. How will you define the toughness index ?

Ans:

Toughness index is defined as the ratio of plasticity index to flow index.

$$I_T = \frac{I_p}{I_f}$$

1.22. What is effective size ?

Ans:

Effective size is the diameter in the grain size distribution curve corresponding to 10 % finer.

1.23. Explain fineness modulus.

Ans:

Fineness modulus is the percentage of fine soil present in the coarse soil. For example in coarse soil 5 % clay and 2 % silt present then fineness modulus equal to 7 %.

1.24. The void ratio of soil sample is 1, determine the corresponding porosity of the soil sample.

Ans:

Given : Void ratio, $e = 1$
 To Find : Porosity.

AKTU 2016-17, Marks 02

Porosity is given by, $n = \frac{e}{1+e} = \frac{1}{1+1} = 0.5$

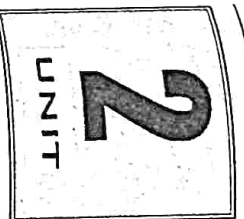

Soil Hydraulics
(2 Marks Questions)

2.1. What do you understand by effective stress ?

Ans: Effective stress is defined as the difference between the total stress and the pore water pressure. It is an abstract quantity and expressed as :

$$\bar{\sigma} = \sigma - u$$

where, σ = Total stress.

u = Pore water pressure.

2.2. What is neutral stress in soil grains ?

Ans: Neutral stress is defined as the stress carried by the pore water and it is the same in all directions. This is also called pore water pressure and is designated by u . This will be equal to $\gamma_w \times Z$ at a depth below the water table.

2.3. What is permeability ?

Ans: The property of a soil which permits flow of water (or any other liquid) through it is called the permeability.

2.4. State the Darcy's law.

AKTU 2016-17, Marks 02

Ans: As per Darcy's law for laminar flow in saturated soils velocity (v) of flow is directly proportional to hydraulic gradient (i).

$$v \propto i$$

$$v = ki$$

where, k = Coefficient of permeability.

2.5. Explain the coefficient of permeability.

AKTU 2016-17, Marks 02

Ans: It is defined as the velocity of flow which would occur under unit hydraulic gradient. Coefficient of permeability,

$$k = \frac{v}{i}$$

2.6. What are the limitations of Darcy's law ?

Ans: The limitations of Darcy's law as follows:

- It is valid if the flow through the soil is laminar.
- It is not valid for colloidal clay.
- The relationship between the velocity and the hydraulic gradient should be approximately linear.

2.7. What are the different characteristics of flownet ?

Ans: The characteristics of flownet can be summarized as under:

- Intersection between a flow line and an equipotential line should be at right angles.
- Discharge (Δq) between any two adjacent flow lines is constant and the drop of head (Δh) between the two adjacent equipotential lines is constant.

2.8. Define analogy method by Laplace equation.

AKTU 2018-19, Marks 02

Ans:

- The electrical analogy method is based on the fact that the Darcy's law, which governs the flow of water through soils, is analogous to the Ohm's law governing the flow of electricity in a conducting medium.
- In the analogy, the current being proportional to the voltage drop is similar to seepage being proportional to head dissipated.
- An electrical model is made whose boundary conditions are similar to those of the soil model. The equipotential lines are drawn by joining the points of equal voltage.
- The flow pattern obtained from the electrical model is used in the construction of flow net in the model.

2.9. List the factors affecting permeability of soils.

AKTU 2019-20, Marks 02

Ans: Following are the factors that affect the permeability of soils:

- Particle size.
- Structure of soil mass.
- Shape of particles.
- Void ratio.
- Properties of water.
- Degree of saturation.
- Adsorbed water.
- Impurities in water.

2.10. What do you mean by hydraulic conductivity ?

AKTU 2016-17, Marks 02

Ans: Hydraulic conductivity is a property of a soil and rocks that describes the ease with which a fluid (usually water) can move through pore spaces or fractures.

2.11. Define the term quick sand condition.

Ans: When the effective stress is reduced due to upward flow of water, a stage is eventually reached when the effective stress is reduced to zero. The condition so developed is known as quick sand condition.

2.12. Define critical gradient.

AKTU 2019-20, Marks 02

Ans: The hydraulic gradient at which the effective stress becomes zero is known as the critical gradient (i_c).

$$i_c = \frac{G-1}{1+e}$$

where,

$$G = \text{Specific gravity.}$$

$$e = \text{Void ratio.}$$

2.13. What are the preventive measures from the piping failures ?

Ans: The following measures generally adopted to prevent piping failures:

- Increasing the path of percolation.
- Reducing seepage.
- Providing drainage filter.
- Loaded filter.

2.14. What is the exit gradient ?

Ans: Exit Gradient: The exit gradient is the hydraulic gradient at the downstream end of the flow line where percolating water leaves the soil mass and emerges into the free water at the downstream. It can be calculated as:

$$i_e = \Delta h/l$$

where,

$$\Delta h = \text{Potential drop in the last field.}$$

$$l = \text{Average length of the last field in the flow net.}$$

2.15. Compute the range for capillary rise in silt deposits. Assume value of void ratio as 0.7.

AKTU 2018-19, Marks 02

Ans:

Given: Void ratio, $e = 0.7$

To Find: Range of capillary rise.

$$\text{Assume, } D_{10} = 0.05 \text{ mm, } C = 40 \text{ mm}^2$$

$$\text{Capillary rise, } h_{(max)} = \frac{C}{e D_{10}} = \frac{40}{0.7 \times 0.05} = 1142.85 \text{ mm}$$





Soil Compaction and Consolidation

(2 Marks Questions)

3.1. What do you mean by soil compaction ?

Ans: Compaction means pressing the soil particles close to each other by mechanical method. Compaction generally increases the shear strength of the soil.

3.2. Design the term relative compaction.

Ans: The ratio of the dry density in the field to the maximum dry density is known as the relative compaction or percent compaction.

$$\text{Relative compaction} = \frac{\rho_d \text{ in the field}}{(\rho_d) \text{ in the laboratory}} \times 100$$

3.3. Differentiate between compression index and expansion index.

AKTU 2019-20, Marks 02

Ans:

S.No.	Compression Index	Expansion Index
i	The compression index is equal to the slope of the linear portion of the void ratio vs. $\log \bar{\sigma}$ plot.	The expansion index or swelling index is the slope of the void ratio vs. $\log \bar{\sigma}$ plot obtained during unloading.
ii	It is generally more than the expansion index.	It is generally less than the compression index.
iii	It is given by, $C_c = \frac{-\Delta e}{\log \left(\frac{\bar{\sigma}}{\bar{\sigma}_0} \right)}$	It is given by, $C_e = \frac{\Delta e}{\log \left(\frac{\bar{\sigma} + \Delta \bar{\sigma}}{\bar{\sigma}} \right)}$

3.4. Give the IS specification for light and heavy compaction test.

OR

What is weight of hammer, height of drop, number of layers as per IS - 2720 part VIII in heavy compaction test ?

AKTU 2015-16, Marks 02

Ans: Following are the IS specification for light and heavy compaction test :

- i. The mould is to be 100 mm diameter, and 127.3 mm high, giving a capacity of 1000 cc – both for light as well as heavy compaction.
- ii. For light compaction, the hammer should have a mass of 2.6 kg and should fall from 310 mm height, on three layers, each layer being given 25 blows, as usual.
- iii. For heavy compaction, the hammer should have a mass of 4.59 kg and should drop from 450 mm height, on five layers, each layer being given 25 blows, as usual.

3.5. What is the recommendation of US Army corps for protective filters ?

AKTU 2015-16, Marks 02

Ans: The filter specifications are given below :

$$\frac{D_{15} \text{ (Filter)}}{D_{85} \text{ (Protected material)}} < 5$$

$$4 < \frac{D_{15} \text{ (Protected material)}}{D_{15} \text{ (Filter)}} < 20$$

$$\frac{D_{50} \text{ (Filter)}}{D_{50} \text{ (Protected material)}} < 25$$

D_{15} , D_{50} and D_{85} refer to the particle sizes from the grain size distribution curves.

3.6. What are the factors affecting compaction ?

Ans: The dry density of the soil is increased by compaction. The increase in the dry density depends upon the following factors :

- i. Water factors.
- ii. Amount of compaction.
- iii. Type of soil.
- iv. Method of compaction.

3.7. What are the methods for compaction used in field ?

Ans: Several methods are used for compaction of soil in field. The choice of the method will depend upon the soil type, the maximum dry density required, and economic consideration.

- i. Tamping.
- ii. Rolling.
- iii. Vibrating.

3.8. Write down the stages of the consolidation process.

Ans: The consolidation of a soil deposit can be divided into three stages :

- i. Initial consolidation.
- ii. Primary consolidation.
- iii. Secondary consolidation.

3.9. Define coefficient of compressibility.

AKTU 2015-16, Marks 02

Ans: Coefficient of compressibility (a_v) is defined as the decrease in void ratio (Δv) per unit increase in effective stress ($\Delta \bar{\sigma}$). It is expressed as :

$$a_v = \frac{-\Delta v}{\Delta \bar{\sigma}}$$

3.10. What is the coefficient of volume change?

Ans: Coefficient of volume change (m_v) is defined as the volumetric strain $\left(\frac{\Delta V}{V_0}\right)$ per unit increase in effective stress ($\Delta \bar{\sigma}$). Thus,

$$m_v = \frac{-\Delta V/V_0}{\Delta \bar{\sigma}}$$

3.11. Discuss the factors affecting the time factor and degree of consolidation.

Ans: The time factor (T_v) and degree of consolidation depends upon :

- i. Thickness of clay layer.
- ii. Number of drainage faces.
- iii. Coefficient of permeability.
- iv. Coefficient of consolidation.
- v. Magnitude of consolidation pressure.

3.12. What is pre-consolidated stress?

AKTU 2018-19, Marks 02

Ans: Pre-consolidation stress is defined to be the maximum effective stress experienced by the soil. This stress is identified in compression with the effective stress in its present state.

3.13. Define over consolidation ratio (OCR).

Ans: Over consolidation ratio is defined as the ratio of the preconsolidation stress (σ_{pc}) to the current effective stress (σ).

$$OCR = \frac{\sigma_{pc}}{\sigma}$$

3.14. Give the expression for the determination of time factor (T_v).

Ans: Time factor is calculated as :

$$T_v = \frac{\pi}{4} U^2$$

$$T_v = -0.933 \log_{10} (1 - U) - 0.085$$

For $U < 60\%$

For $U > 60\%$

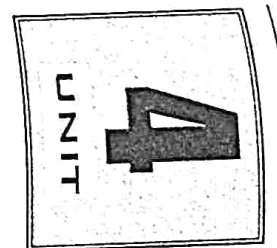

Stress Distribution in Soil and Shear Strength (2 Marks Questions)

4.1. Define the shear strength of soil.

AKTU 2016-17, Marks 02

Ans: It may be defined as the maximum resistance offered by shear stresses before the failure.

4.2. Write down the various tests for determining the shear strength of soil.

Ans: The following tests are available for determining the shear strength of soil :

1. Laboratory Test :
 - i. Direct shear test.
 - ii. Triaxial compression test.
 - iii. Unconfined compression test.
 - iv. Laboratory vane shear test.
 - v. Torsion test.
 - vi. Ring shear test.
2. Field Test :
 - i. Vane shear test.
 - ii. Penetration test.

4.3. Discuss the advantages of direct shear test.

Ans: The test has several advantages. Some of them are as follows :

- i. It is quick, inexpensive and simple.
- ii. Samples can be sheared along predetermined planes, when the shear strength along fissures or other selected planes are needed.

4.4. Give the disadvantages of direct shear test.

Ans: Following are the disadvantages of direct shear test :

- i. The failure plane is always horizontal in the test, and this may not be the weakest plane in the sample.
- ii. There is no provision for measuring pore water pressure in the shear box and so it is not possible to determine effective stresses from undrained test.

4.5. What is platen or end effect in shearing strength?

AKTU 2015-16, Marks 02

Ans: Platen in shearing strength is a flat plate, especially one that exerts or receives pressure.

46. Explain in brief about stress isobar or isobar diagram.
AKTU 2015-16, Marks 02

OR

Explain the isobar.
AKTU 2016-17, Marks 02

Ans. An 'isobar' is a stress contour or a line which connects all points below the ground surface at which the vertical pressure is the same. The isobar of stress has shape of bulb, so it is also known as pressure bulb.

47. Define undrained shearing strength.
AKTU 2018-19, Marks 02

Ans. The shear strength of a fine grained soil under undrained condition is called the undrained shear strength.

48. What are the limitations of coulomb's theory ?
AKTU 2018-19, Marks 02

Ans. Limitations of Coulomb's Theory :

- i. It neglects the effect of the intermediate principal stress.
- ii. This theory, approx the failure envelope into straight line which may be a little curve for over consolidated clays.
- iii. For some clay there is no fixed relationship between the normal and shear stresses on the plane of failure. This theory cannot be used for such soils.
- iv. In case of pure clays, according to this theory, shear strength is constant with the depth. However in practice a little increase is observed.

49. Write down the assumptions of Boussinesq equation theory.

Ans. Following are the assumption of Boussinesq theory :

- i. The soil mass is an elastic continuum, having a constant value of modulus of elasticity (E), i.e., the ratio between the stress and strain is constant.
- ii. The soil is homogeneous, i.e., it has identical properties at different points.
- iii. The soil is isotropic, i.e., it has identical properties in all directions.
- iv. The soil mass is semi-infinite, i.e., it extends to infinity in the downward direction and lateral directions.
- v. The soil is weightless and is free from residual stresses before the application of the load.

4.10. What are the assumptions of Westergaard's theory ?

Ans. Following are the assumptions of Westergaard's theory :

- i. The soil is elastic and semi-infinite.
- ii. Soil is composed of numerous closely spaced horizontal layers of negligible thickness of an infinite rigid material.
- iii. The rigid material permits only the downward deformation of mass in which horizontal deformation is zero.

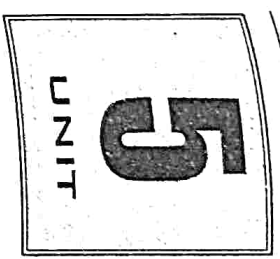

Earth Pressure and Stability of Slopes
(2 Marks Questions)

5.1. Define the term earth pressure.

Ans. The soil that is retained at a slope steeper than it can sustain by virtue of its shearing strength, exerts a force on the retaining wall. This force is called the earth pressure.

5.2. Classify the lateral earth pressure.

Ans. The three categories of lateral earth pressure are :
 i. At rest earth pressure. ii. Active pressure. iii. Passive pressure.

5.3. Differentiate active and passive earth pressure.

AKTU 2017-18, Marks 02

OR

Define active earth pressure in brief.

AKTU 2016-17, Marks 02

S.No.	Active Earth Pressure	Passive Earth Pressure
1.	It is a lateral pressure exerted by the soil mass on retaining wall.	It is a lateral pressure exerted by the retaining wall on soil mass.
2.	Movement of retaining wall away from the back fill.	Movement of retaining wall toward the back fill.
3.	Coefficient of active earth pressure, $K_a = \frac{1 - \sin \phi}{1 + \sin \phi}$.	Coefficient of passive earth pressure, $K_p = \frac{1 + \sin \phi}{1 - \sin \phi}$.
4.	Active earth pressure is less than resting pressure.	Passive earth pressure is more than resting pressure.

5.4. Draw pressure distribution diagram for submerged soil mass.

AKTU 2015-16, Marks 02

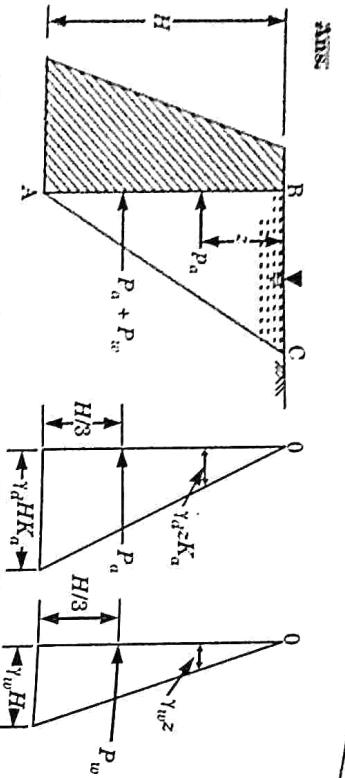

Fig. 5.4.1. Pressure distribution for submerged soil condition.

5.5. What are the limitations of Rankine theory ?

AKTU 2015-16, Marks 02

- Ans: Following are the limitations in Rankine theory :
- i. The retained soil may not be always cohesionless.
 - ii. The wall back may not always be vertical.
 - iii. The back of the wall is never smooth, and hence friction develops.

5.6. Give the factors affecting of coefficient of earth pressure.

- Ans: Coefficient of earth pressure depends upon :
- i. The angle of back of soil,
 - ii. The soil wall friction value,
 - iii. The angle of backfill.

5.7. Define slope. Where it is used ?

Ans: An earth slope is an unsupported inclined surface of a soil mass. Earth slopes are formed for railway formations, highway embankments, earth dams, canal banks, levees and at many other locations.

5.8. What are the assumptions made for the analysis of slopes ?

- Ans: The following assumptions are generally made for slopes :
- i. The stress system is assumed to be two-dimensional. The stresses in the third direction are taken as zero.
 - ii. It is assumed that the Coulomb equation for shear strength is applicable and the strength parameters and ϕ are known.

5.9. Define factor of safety with respect to shear strength.

Ans: The factor of safety is defined as the ratio of the shear strength (s) to the shear stress (τ_m) along the surface of failure.

Factor of safety,
$$F_s = \frac{s}{\tau_m}$$

5.10. Explain factor of safety with respect to cohesion.

Ans: The factor of safety with respect to cohesion (F_c) is the ratio of the available cohesion intercept (c) and the mobilized cohesion intercept (c_m).

Thus, Factor of safety,
$$F_c = \frac{c}{c_m}$$

5.11. What do you understand by factor of safety with respect to friction ?

Ans: The factor of safety with respect to friction is the ratio of the available frictional strength to the mobilized frictional strength.

Thus,
$$F_\phi = \frac{\tan \phi}{\tan \phi_m}$$

5.12. What are different types of slope failures ?

AKTU 2019-20, Marks 02

- Ans: Following are the various types of slope failures :
- i. Rotational failure.
 - ii. Translational failure.
 - iii. Compound failure.
 - iv. Wedge failure.
 - v. Miscellaneous failure.

5.13. Give the expression for stability number.

Ans: Stability number is proportional to the required cohesion and is inversely proportional to the allowable height.

$$S_n = \frac{c}{f_c \gamma H}$$

Stability number is a dimensionless quantity.

5.14. Define stability factor.

Ans: Stability factor is the reciprocal of the stability number.

Stability factor =
$$\frac{1}{S_n} = \frac{f_c \gamma H}{c}$$

5.15. What is the most critical circle ?

Ans: The circle which gives the minimum factor of safety is the most critical circle.

5.16. How can you improve the stability of slopes ?

- Ans: These are following measures which improve stability of slopes :
- i. Slope flattening reduces the weight of the mass tending to slide. It can be used wherever possible.
 - ii. Consolidation by surcharging, electro-osmosis or other methods helps in increasing the stability of slope.
 - iii. Grouting and injection of cement or other compounds into specific zones help in increasing the stability of slopes.
 - iv. Stabilization of the soil helps in increasing the stability of slopes.



B. Tech.
(SEM. V) ODD SEMESTER THEORY
EXAMINATION, 2015-16
GEOTECHNICAL ENGINEERING

Time : 3 Hours

Max. Marks : 100

SECTION - A

1. Attempt all parts. All parts carry equal marks. Write answer of each part in short. (2 × 10 = 20)
 2. What is muck?
- Ans: Refer Q. 1.3. 2 Marks Questions, Page SQ-1A, Unit-1.
- b. Briefly explain single grain structure.

Ans: Refer Q. 1.12. 2 Marks Questions, Page SQ-3A, Unit-1.
- c. Draw pressure distribution diagram for submerged soil mass.

Ans: Refer Q. 5.4. 2 Marks Questions, Page SQ-14A, Unit-5.
- d. What is weight of hammer, height of drop, number of layers as per IS - 2720 part VIII in heavy compaction test?

Ans: Refer Q. 3.4. 2 Marks Questions, Page SQ-9A, Unit-3.
- e. What is the recommendation of US Army corps for protective filters?

Ans: Refer Q. 3.5. 2 Marks Questions, Page SQ-10A, Unit-3.
- f. Explain in brief about stress isobar or isobar diagram.

Ans: Refer Q. 4.6. 2 Marks Questions, Page SQ-13A, Unit-4.
- g. Define coefficient of compressibility.

Ans: Refer Q. 3.9. 2 Marks Questions, Page SQ-11A, Unit-3.
- h. What are the limitations of Rankine theory?

Ans: Refer Q. 5.5. 2 Marks Questions, Page SQ-15A, Unit-5.
- i. What is platen or end effect in shearing strength?

Ans: Refer Q. 4.5. 2 Marks Questions, Page SQ-12A, Unit-4.
- j. What is inside and outside clearance in soil exploration?

Ans: This questions is out of syllabus from session 2020-21.

SECTION - B

Attempt any five parts of the following. All parts carry equal marks.

1. What are the limitations in the use of Stoke's law in sedimentation analysis? (5 × 10 = 50)

Ans: Refer Q. 1.24, Page, 1-25A, Unit-1.
2. A bed of sand consists of three horizontal layers of equal thickness. The magnitude of the coefficient of permeability for both the upper and lower layers is 4×10^{-4} mm/sec and for middle layer is 6×10^{-2} mm/sec. What is the ratio of average permeability of bed in horizontal direction to that in vertical direction?

Ans: Refer Q. 2.12, Page, 2-14A, Unit-2.
3. What is piping in hydraulic structure? Suggest some remedial measure to check or prevent it.

Ans: Refer Q. 2.23, Page, 2-27A, Unit-2.
4. A concentrated load 10 kN acts on the surface of a soil mass. Using Boussinesq analysis, find the vertical stress at points (i) 3 m below the surface on the axis of loading, and (ii) at radial distance of 2 m from axis of loading and at depth of 3 m.

Ans: Refer Q. 4.5, Page, 4-7A, Unit-4.
5. A soil sample 20 mm thick takes 20 min. to reach 20 % consolidation. Find the time taken for a clay layer 6 m thick to reach 40 % consolidation. Assume double drainage in both cases.

Ans: Refer Q. 3.19, Page, 3-22A, Unit-3.
6. What are the advantages and disadvantages of triaxial compression test?

Ans: Refer Q. 4.19, Page, 4-22A, Unit-4.
7. Using the Rankine theory, determine the total active thrust on a vertical retaining wall 10 m high if the soil retained has the following properties $\phi = 35^\circ$; $\gamma = 19$ kN/m³. What is the increase in horizontal thrust if the soil slopes up from the top of the wall at an angle of 35° to the horizontal?

Ans: Refer Q. 5.9, Page, 5-12A, Unit-5.
8. Explain SPT test. Also, explain the corrections used for the test.

Ans: This question is out of syllabus from session 2020-21.

SECTION - C

Attempt any two parts of the following. All parts carry equal marks.

9. A natural soil deposit has bulk unit weight of 18.5 kN/m³ and water content of 5%. Calculate the amount of water required to be added to 5 m³ of soil to raise the water content to 14%. Assume the void ratio to remain constant. Also find degree of saturation, assume $G = 2.65$.

Ans: Refer Q. 1.14, Page, 1-16A, Unit-1.

10. What are the Skempton's pore pressure parameters? Derive an expression between pore water pressure and applied stress.

Ans: Refer Q. 4.22, Page, 4-27A, Unit-4.

11. Explain field methods to determine permeability.

Ans: Refer Q. 2.13, Page, 2-15A, Unit-2.



B. Tech.

(SEM. V) ODD SEMESTER THEORY
EXAMINATION, 2016-17
GEOTECHNICAL ENGINEERING

Time : 3 Hours

Max. Marks : 100

- Note : i. Attempt all questions.
ii. Assume any data suitably, if required.

1. Attempt all parts. Each part carries equal marks. (10 × 2 = 20)
a. Define the shear strength of soil.

Ans: Refer Q. 4.1, 2 Marks Questions, Page SQ-12A, Unit-4.

- b. Explain the coefficient of permeability.

Ans: Refer Q. 2.5, 2 Marks Questions, Page SQ-6A, Unit-2.

- c. What do you mean by hydraulic conductivity?

Ans: Refer Q. 2.10, 2 Marks Questions, Page SQ-7A, Unit-2.

- d. Define void ratio, bulk unit weight and specific gravity.

Ans: Refer Q. 1.7, Page 1-5A, Unit-1.

- e. The void ratio of soil sample is 1, determine the corresponding porosity of the soil sample.

Ans: Refer Q. 1.24, 2 Marks Questions, Page SQ-5A, Unit-1.

- f. Explain the isobar.

Ans: Refer Q. 4.6, 2 Marks Questions, Page SQ-13A, Unit-4.

- g. Briefly explain the flocculant grain structure.

Ans: Refer Q. 1.13, 2 Marks Questions, Page SQ-3A, Unit-1.

- h. State the Darcy's law.

Ans: Refer Q. 2.4, 2 Marks Questions, Page SQ-6A, Unit-2.

- i. Define index properties of soil.

Ans: Refer Q. 1.15, 2 Marks Questions, Page SQ-3A, Unit-1.

- j. Define active earth pressure in brief.

Ans: Refer Q. 5.3, 2 Marks Questions, Page SQ-14A, Unit-5.

2. Attempt any five questions :

- a. Explain SPT test. Write the procedure in brief.

Ans: This question is out of syllabus from session 2020-21.

(5 × 10 = 50)

b. A soil sample 40 mm thick takes 40 minute to reach 40 % consolidation. Find the time taken for a clay layer 8 m thick to reach 80 % consolidation. Assume double drainage in both cases.

Ans: Refer Q. 3.18, Page 3-21A, Unit-3.

c. Compare between compaction and consolidation.

Ans: Refer Q. 3.10, Page 3-11A, Unit-3.

d. A soil specimen has a water content of 15 % and a wet unit weight of 25 kN/m³. If the specific gravity of solids is 2.70, determine the dry unit weight, void ratio and the degree of saturation, take $\gamma_w = 10$ kN/m³.

Ans: Refer Q. 1.15, Page 1-17A, Unit-1.

e. A square footing has dimensions of 2 m x 2 m and a depth of 3 m. Determine its ultimate bearing capacity in pure clay with an unconfined strength of 0.15 N/mm², $\phi = 0^\circ$ and $\gamma = 1.7$ g/cm³. Assume Terzaghi's factors for $\phi = 0$, as $N_q = 5.7$, $N_g = 1$ and $N_\gamma = 0$.

Ans: This Question is out of syllabus from session 2020-21.

f. Write the short notes on :

i. Field compaction control. ii. Proctor needle method.

Ans: Refer Q. 3.4, Page 3-5A, Unit-3.

g. Drive the Laplace's equation of continuity with all assumptions.

Ans: Refer Q. 2.18, Page 2-22A, Unit-2.

h. Define the Skempton's pore pressure parameters. Derive an expression between pore water pressure and applied stress.

Ans: Refer Q. 4.22, Page 4-27A, Unit-4.

3. Attempt any two parts of the following :

(2 x 15 = 30)

a. Explain the field methods for compaction of soil in details.

Ans: Refer Q. 3.3, Page 3-3A, Unit-3.

b. A soil sample of saturated soil has a water content of 35 % and bulk unit weight of 25 kN/m³. Determine dry density, void ratio and specific gravity of solid particles. What would be the bulk unit weight of the same soil at the same void ratio but at a degree of saturation 60 %, take $\gamma_w = 10$ kN/m³.

Ans: Refer Q. 1.16, Page 1-17A, Unit-1.

c. What do you mean by site investigation ? What are the different purposes for which site investigation is done ?

Ans: This Question is out of syllabus from session 2020-21.



B. Tech.
(SEM. V) ODD SEMESTER THEORY
EXAMINATION, 2017-18
GEOTECHNICAL ENGINEERING

Time : 3 Hours

Max. Marks : 100

Note : Attempt all sections. If any missing data required, then choose suitably.

SECTION - A

1. Attempt all questions in brief.

(2 x 10 = 20)

a. What do you understand about index properties ?

Ans: Refer Q. 1.15, 2 Marks Questions, Page SQ-4A, Unit-1.

b. What is meant by 'primary valence bond' and 'secondary valence bond' ?

Ans: Refer Q. 1.19, Page 1-19A, Unit-1.

c. Write methods to determine the water content.

Ans: Refer Q. 1.5, 2 Marks Questions, Page SQ-2A, Unit-1.

d. Define bulk unit weight. Write the relation between bulk unit weight and dry unit weight.

Ans: Refer Q. 1.7, 2 Marks Questions, Page SQ-2A, Unit-1.

e. What is Muick ?

Ans: Refer Q. 1.3, 2 Marks Questions, Page SQ-1A, Unit-1.

f. Define Consistency limits.

Ans: Refer Q. 1.8, 2 Marks Questions, Page SQ-2A, Unit-1.

g. Differentiate between Activity and Sensitivity.

Ans: Refer Q. 1.18, 2 Marks Questions, Page SQ-4A, Unit-1.

h. Differentiate Active and passive earth pressure.

Ans: Refer Q. 5.3, 2 Marks Questions, Page SQ-14A, Unit-5.

i. What are the assumptions made in the derivation of

Terzaghi's bearing capacity theory ?

Ans: This question is out of syllabus from session 2020-21.

j. What is Mohr's circle ? Discuss its important characteristics.

Ans: Refer Q. 4.13, Page 4-18A, Unit-4.

SECTION-B

2. Attempt any three of the following: (3 × 10 = 30)
- a. Determine the ultimate bearing capacity of a strip footing, 1.20 m wide, and having the depth of foundation of 1.0 m. Use Terzaghi's theory and assume general shear failure. Take $\phi = 35^\circ$, $\gamma = 18 \text{ kN/m}^3$, and $c' = 15 \text{ kN/m}^2$.
- Ans: This question is out of syllabus from session 2020-21.

- b. What are the basic characteristics of the failure mechanisms in general shear failure, local shear failure and punching shear failure? Also differentiate between ultimate bearing capacity, safe bearing capacity, safe bearing pressure and allowable bearing pressure.
- Ans: This question is out of syllabus from session 2020-21.

- c. For a sedimentary soil deposit, which solution is more appropriate Boussinesq's or Westergaard's. Why? State the assumptions involved in the Westergaard's theory. A concentrated load of 40 kN acts on the surface of a soil. Determine the vertical stress increment at points directly beneath the load upto a depth of 10 m and draw a plot for the vertical stress variation upto depth of 10 m.
- Ans: Reason and Numerical: Refer Q. 4.6, Page 4-7A, Unit-4. Assumptions: Refer Q. 4.1, Page 4-2A, Unit-4.

- d. i. Let us suppose as a geotechnical expert, you have a challenge to control the compaction in a site; so how will you control the compaction by the Proctor's needle method?
- Ans: Refer Q. 3.4, Page 3-5A, Unit-3.

- ii. As a geotechnical engineer for the design of a filter of an earth dam, the proper selection of filter material is required to prevent the piping failure; so what are the conditions, you will keep in your mind at the time of filter design?
- Ans: Refer Q. 2.25, Page 2-29A, Unit-2.

- e. i. What do you understand by residual soils and transported soils? Give the grain size range of different soil types according to IS specifications.

Ans: Residual and Transported soils: Refer Q. 1.1, Page 1-2A, Unit-1.
Grain Size Range of Different Soil: Refer Q. 1.34, Page 1-34A, Unit-1.

- ii. Establish the following relationship

where, $S_e = wG$
 $S =$ Degree of saturation,
 $e =$ Void ratio,
 $w =$ Water content,
 $G =$ Specific gravity of soil solids.

Ans: Refer Q. 1.8, Page 1-7A, Unit-1.

SECTION-C

3. Attempt any one part of the following: (1 × 10 = 10)
2. A mass of soil is coated with thin layer of wax, weight of soil and wax is 690.6 gm. Soil alone has 683 gm. When this sample is immersed in water it displaces 350 ml of water. Sp. Gravity of solids is 2.73 and that of wax 0.89. Find Void ratio and degree of saturation if water content in the soil is 17%.

Ans: Refer Q. 1.17, Page 1-18A, Unit-1.

- b. i. Illustrate by schematic diagrams, how the clay minerals kaolinite, illite and montmorillonite are formed.

Ans: Refer Q. 1.21, Page 1-21A, Unit-1.

- ii. An oven dry soil sample of volume 250 cc weighs 430 g. If the specific gravity of solids is 2.70, what is the water content when the soil becomes fully saturated without any change in its volume? What will be the water content which will fully saturate the sample and also cause an increase in volume equal to 10% of the original dry volume?

Ans: Refer Q. 1.10, Page 1-12A, Unit-1.

4. Attempt any one part of the following: (1 × 10 = 10)
- a. What are different methods for determination of the coefficient of permeability in a laboratory? Discuss their limitations.

Ans: Refer Q. 2.8, Page 2-9A, Unit-2.

- b. Explain how upward flow of seepage water causes the effective stress. What is the role of the pore water pressure in the quick sand condition?

Ans: Refer Q. 2.21, Page 2-26A, Unit-2.

5. Attempt any one part of the following: (1 × 10 = 10)
- a. Derive an expression for the vertical stress under a circular area. Determine the vertical stress at a point P which is 3 m below and at a radial distance of 3 m from the vertical load of 100 kN. Use Westergaard's solution.

Ans: Refer Q. 4.7, Page 4-9A, Unit-4.

b. Give the assumptions of the Terzaghi's theory for calculating the rate of 1D-consolidation and prove that

$$\frac{\partial u}{\partial t} = c_v \frac{\partial^2 u}{\partial z^2}$$

Ans: Refer Q. 3.12, Page 3-12A, Unit-3.

6. Attempt any one part of the following: (1 x 10 = 10)

a. According to Mohr - Coulomb criterion, how is the failure plane recognized and how is shear strength defined? The effective stress shear strength parameters of completely saturated clay are: $c' = 20 \text{ kN/m}^2$, $\phi' = 25^\circ$. A sample of this clay was tested in an unconsolidated undrained test under a cell pressure of 200 kN/m^2 and the principal stress difference at failure was 110 kN/m^2 . What was the value of pore water pressure at failure?

Ans: Mohr - Coulomb : Refer Q. 4.14, Page 4-18A, Unit-4.
Numerical : Refer Q. 4.25, Page 4-31A, Unit-4.

b. In an in-situ vane shear test on saturated clay, a torque of 35 N-m was required to shear the soil. The diameter of the vane was 50 mm and length 100 mm . Calculate the undrained shear strength of the clay. The vane was then rotated rapidly to cause remoulding of the soil. The torque required to shear the soil in the remoulded state was 5 N-m . Determine the sensitivity of the clay.

Ans: Refer Q. 4.27, Page 4-32A, Unit-4.

7. Attempt any one part of the following: (1 x 10 = 10)

a. Differentiate between gross and net bearing capacity. What are the assumptions made in the Terzaghi's bearing capacity theory? Also discuss the failure zones in Terzaghi's theory with the help of its neat sketch.

Ans: This question is out of syllabus from session 2020-21.

b. Determine the ultimate bearing capacity of a strip footing 2 m width, with its base at a depth of 1.5 m below the ground surface and resting on a saturated clay soil with the following properties:

$$\gamma_{\text{sat}} = 20 \text{ kN/m}^3; c_u = 40 \text{ kN/m}^2, \phi_u = 0; c' = 10 \text{ kN/m}^2, \phi = 20^\circ$$

For $\phi = 20^\circ; N_c = 17.7, N_q = 7.4, N_\gamma = 5.0$
The natural water table is at 1 m depth below the ground level. Ignore the depth factors.

Ans: This question is out of syllabus from session 2020-21.



B. Tech.
(SEM. V) ODD SEMESTER THEORY
EXAMINATION, 2018-19
GEOTECHNICAL ENGINEERING

Time : 3 Hours

Max. Marks : 100

Note : Attempt all sections. If any missing data required, then choose suitably.

SECTION - A

1. Attempt all questions in brief. (2 x 7 = 14)
a. Define origin of soil.

Ans: Refer Q. 1.1, 2 Marks Questions, Page SQ-1A, Unit-1.

b. Draw the figure of element separated soil into three phases.
Ans: Refer Q. 1.4, 2 Marks Questions, Page SQ-1A, Unit-1.

c. Compute the range for capillary rise in silt deposits. Assume value of void ratio as 0.7.

Ans: Refer Q. 2.15, 2 Marks Questions, Page SQ-8A, Unit-2.

d. Define analogy method by Laplace equation.
Ans: Refer Q. 2.8, 2 Marks Questions, Page SQ-7A, Unit-2.

e. What are the preconsolidated stress?

Ans: Refer Q. 3.12, 2 Marks Questions, Page SQ-11A, Unit-3.

f. Define undrained shearing strength.

Ans: Refer Q. 4.7, 2 Marks Questions, Page SQ-13A, Unit-4.

g. What are the limitations of coulomb's theory?

Ans: Refer Q. 4.8, 2 Marks Questions, Page SQ-13A, Unit-4.

SECTION-B

(7 x 3 = 21)

2. Attempt any three of the following:
a. What is the use of particle size distribution curve.
the help of particle size distribution curve?

Ans: Refer Q. 1.26, Page 1-26A, Unit-1.

b. The specific gravity of soil solids for a given soil sample was determined by density bottle method using kerosene.

Following observations were recorded. Compute the specific gravity of soil solids at test temperature which was maintained at 27°. Also report the value at 4°C. Take specific gravity of kerosene at 27°C as 0.733.

Ans. Refer Q. 1.12, Page 1-14A, Unit-1.

c. Define the terms:

i. Quick sand condition.

Ans. Refer Q. 2.21, Page 2-27A, Unit-2.

ii. Exit gradient.

Ans. Refer Q. 2.14, 2 Marks Questions, Page SQ-8A, Unit-2.

iii. UU test.

Ans. Refer Q. 4.20, Page 4-24A, Unit-4.

d. In the laboratory a 2 cm thick soil sample takes 25 minutes to reach 30% degree of consolidation. Find the time taken for a 5 m thick clay layer in field to reach 40% consolidation. Assume double drainage both cases.

Ans. Refer Q. 3.21, Page 3-24A, Unit-3.

e. Using the Rankine's theory, the total active thrust on a vertical wall 10 m high, if the soil retained has the following properties, $\phi = 35^\circ$, $\gamma = 19 \text{ kN/m}^3$. What is the increase in horizontal thrust if the soil slopes up from the top of the wall at an angle of 35° to be horizontal?

Ans. Refer Q. 5.9, Page 5-12A, Unit-5.

SECTION-C

3. Attempt any one part of the following: (7 × 1 = 7)

a. The plastic limit of soils is 24% and its plasticity index is 8%. When the soil is dried from its state of plastic limit, the volume change is 26% of its volume of plastic limit. The corresponding volume change from liquid limit to dry state is 35% of its volume of liquid limit. Determine the shrinkage limit and the shrinkage ratio.

Ans. Refer Q. 1.32, Page 1-31A, Unit-1.

b. Define clay minerals. Also discuss montmorillonite with neat sketches.

Ans. Refer Q. 1.21, Page 1-21A, Unit-1.

4. Attempt any one part of the following:

(7 × 1 = 7)

a. Explain capillary siphoning with neat sketch. Also discuss about partially saturated soil.

Ans. Refer Q. 2.24, Page 2-29A, Unit-2.

b. What are the assumption and limitations of Dupuit's theory?

Ans. Refer Q. 2.19, Page 2-24A, Unit-2.

5. Attempt any one part of the following:

(7 × 1 = 7)

a. Find out the expression for the law of deflection of flow line at the interface of two dissimilar soils.

Ans. Refer Q. 2.11, Page 2-13A, Unit-2.

b. Write the difference between compaction and consolidation. The in-situ void ratio of a granular soil deposits is 0.50. The maximum and minimum soil ratio of the soil were determined to be 0.75 and 0.35, $G_s = 2.67$, also determine the relative density and relative compaction of the deposit.

Ans. Difference: Refer Q. 3.10, Page 3-10A, Unit-3.
Numerical: Refer Q. 3.8, Page 3-9A, Unit-3.

6. Attempt any one part of the following:

(7 × 1 = 7)

a. In a consolidation test, the void ratio of the specimen which was 1.068 under the effective pressure of 214 kN/m^2 , changed to 0.994 when the pressure was increased to 429 kN/m^2 . Calculate the coefficient of permeability, compression index. Also find the settlement of foundation resting on above type of clay, if thickness of layer is 8 m and the increase in pressure is 10 kN/m^2 .

Ans. Refer Q. 3.26, Page 3-28A, Unit-3.

b. A rectangular area $2 \text{ m} \times 4 \text{ m}$ carries a uniform load of 8 t/m^2 at the ground surface. Find the vertical pressure at 5 m below the centre and corner of the loaded area.

Ans. Refer Q. 4.4, Page 4-6A, Unit-4.

7. Attempt any one part of the following:

(7 × 1 = 7)

a. A ground of 16 piles of 600 mm diameter is arranged in a square pattern with c/c spacing of 1.2 m the piles are 10 m long and are embedded in soft clay with cohesion of 30 kN/m^2 . Bearing resistance may be neglected for the piles. Adhesion factor is 0.6. Determine ultimate load carrying capacity of the pile group.

Ans. This question is out of syllabus from session from 2020-21.

b. What are the cased cast-in-situ concrete piles? Explain any two of them with neat sketches.

Ans. This question is out of syllabus from session from 2020-21.



**(SEM. V) ODD SEMESTER THEORY
EXAMINATION, 2019-20
GEOTECHNICAL ENGINEERING**

B.Tech.

Time : 3 Hours

Max. Marks : 70

Note : Attempt all sections. Assume any missing data.

Section - A

1. Attempt all questions in brief.

(2 × 7 = 14)

a. Explain index properties of soil.

Ans: Refer Q. 1.15, 2 Marks Questions, Page SQ-3A, Unit-1.

b. What are the basic structural units of clay minerals ?

Ans: Refer Q. 1.11, 2 Marks Questions, Page SQ-3A, Unit-1.

c. List the factors affecting permeability of soils.

Ans: Refer Q. 2.9, 2 Marks Questions, Page SQ-7A, Unit-2.

d. Define critical gradient.

Ans: Refer Q. 2.12, 2 Marks Questions, Page SQ-8A, Unit-2.

e. Differentiate between compression index and expansion index.

Ans: Refer Q. 3.3, 2 Marks Questions, Page SQ-9A, Unit-3.

f. What are different types of slope failure ?

Ans: Refer Q. 5.12, 2 Marks Questions, Page SQ-16A, Unit-5.

g. Describe various types of pile foundation.

Ans: This question is out of syllabus from session 2020-21.

Section - B

2. Attempt any three of the following :

(7 × 3 = 21)

a. Prove that dry unit weight of soil.

$$\gamma_d = \frac{(1 - n_u)G_s \gamma_w}{1 + e}$$

Ans: Refer Q. 1.8, Page 1-7A, Unit-1.

b. Explain flow net. Describe its properties and its applications.

Ans: Flow net and Properties: Refer Q. 2.15, Page 2-21A, Unit-2.
Application: Refer Q. 2.16, Page 2-22A, Unit-2.

c. A normally consolidated clay layer of 10 m thickness has a unit weight of 20 kN/m³ and specific gravity of 2.72. The liquid limit of the clay is 58%. A structure constructed on the clay increases the overburden pressure by 10%. Estimate the consolidation settlement.

Ans: Refer Q. 3.25, Page 3-27A, Unit-3.

d. Describe the unconfined compression test ? What is its advantage over a triaxial test ?

Ans: Refer Q. 4.17, Page 4-21A, Unit-4.

e. Using Terzaghi's theory, determine the ultimate bearing capacity of a strip footing 1.5 m wide resting on a saturated clay ($c_u = 30 \text{ kN/m}^2$, $\phi_u = 0$ and $\gamma_{sat} = 20 \text{ kN/m}^3$), at a depth of 2 m below ground level. The water table is also at a depth of 2 m from the ground level. If the water table rises by 1 m, calculate the percentage reduction in the ultimate bearing capacity.

Ans: This question is out of syllabus from session 2020-21.

Section - C

3. Attempt any one part of the following :

(7 × 1 = 7)

a. Saturated clay has a water content of 39.3% and a mass specific gravity of 1.84. Determine the void ratio and the specific gravity of soil solids.

Ans: Refer Q. 1.18, Page 1-19A, Unit-1.

b. The liquid limit of clay is 64% and its plastic limit is 34%. Its natural water is 48%. What is the liquidity index of the soil ? How do you classify the soil as per the IS classification ?

Ans: Refer Q. 1.31, Page 1-31A, Unit-1.

(7 × 1 = 7)

4. Attempt any one part of the following :

a. A granular soil deposit is 7 m deep over an impermeable layer. The ground water table is 4 m below the ground surface. The deposit has a zone of capillary rise of 1.2 m with a saturation of 50%. Plot the variation of total stress, pore water pressure and effective stress with the depth of deposit, $e = 0.6$ and $G = 2.65$.

Ans: Refer Q. 2.6, Page 2-7A, Unit-2.

b. A soil sample 90 mm high and 6000 mm² in cross-section as subjected to a falling-head permeability test. The head fell

from 500 mm to 300 mm in 1500 sec. The permeability of the soil was 2.4×10^{-3} mm/sec. Determine the diameter of the stand pipe.

Ans. Refer Q. 2.9, Page 2-11A, Unit-2.

(7 × 1 = 7)

5. Attempt any one part of the following :
 a. Describe standard proctor test and the modified proctor test.

Ans. Refer Q. 3.5, Page 3-6A, Unit-3.

- b. A saturated clay layer of 5 m thickness takes 1.5 years for 50 % primary consolidation, when drained on both sides. Its coefficient of volume change m_v is 1.5×10^{-3} m²/kN. Determine the coefficient of consolidation (in m²/yr) and the coefficient of permeability (in m/yr).

Ans. Refer Q. 3.20, Page 3-23A, Unit-3.

(7 × 1 = 7)

6. Attempt any one part of the following :
 a. Explain the Skempton's pore pressure parameters in detail.

Ans. Refer Q. 4.22, Page 4-28A, Unit-4.

- b. How a slope is analyzed using Swedish circle method ? Derive an expression for the factor of safety.

Ans. Refer Q. 5.17, Page 5-21A, Unit-5.

(7 × 1 = 7)

7. Attempt any one part of the following :

- a. Define the following terms :
 i. Net safe bearing capacity.
 ii. Gross safe bearing capacity.
 iii. Allowable soil pressure.

Ans. This question is out of syllabus from session 2020-21.

- b. A group of 9 piles, 10 m long is used as a foundation for a bridge pier, the piles used are 30 cm diameter with centre to centre spacing of 0.9 m, the subsoil consists of clay with unconfined compressive strength of 1.5 kg/cm². Determine the efficiency neglecting the bearing action, $\alpha = 0.9$.

Ans. This question is out of syllabus from session 2020-21.



B.Tech.

(SEM. V) ODD SEMESTER THEORY
 EXAMINATION, 2020-21

GEOTECHNICAL ENGINEERING

Time : 3 Hours

Max Marks : 100

Note: 1. Attempt all Sections. If require any missing data, then choose suitably.

SECTION - A

1. Attempt all questions in brief: (2 × 10 = 20)
 a. Explain the process of soil formation. Differentiate between residual and transported soil.

Ans. Process : Soil is formed by weathering of rock due to mechanical disintegration or chemical decomposition. When a rock surface gets exposed to atmosphere for an appreciable time, it disintegrates or decomposes into small particles and thus the soils are formed. Difference : Refer Q. 1.2, Page 1-2A, Unit-1.

- b. Derive the formula between soil moisture content (w), degree of saturation (S), specific gravity (G) and void ratio (e).

Ans. Refer Q. 1.8(b), Page 1-8A, Unit-1.

- c. What are the factors affecting the permeability of soils ?

Ans. Refer Q. 2.9, 2 Marks Questions, Page Sq-7A, Unit-2.

- d. What do you understand by the term "Flow net" ?

Ans. Refer Q. 2.15, Page 2-20A, Unit-2.

- e. Define total stress, neutral stress and effective stress.

Ans. Refer Q. 2.1, Page 2-2A, Unit-2.

- f. Define consolidation. How it is differ from compaction ?

Ans. Refer Q. 3.10, Page 3-10A, Unit-3.

- g. List the assumptions made in Boussinesq's theory.

Ans. Refer Q. 4.9, 2 Marks Questions, Page Sq-13A, Unit-4.

- h. How do you define "failures" in soils ?

Ans. When soil is loaded, shearing stresses are induced in it. When the shearing stresses reach a limiting value, shear deformation takes place, leading to the failure of the soil mass.

- i. What are the different types of earth pressures ?

Ans. Refer Q. 5.2, 2 Marks Questions, Page Sq-14A, Unit-5.

- j. What are the assumptions in Rankine's theory ?

Ans. Refer Q. 5.2, Page 5-3A, Unit-5.

(3 × 10 = 30)

2. Attempt any three of the following :

- a. A natural deposit has bulk unit weight of 18.5 kN/m³ and water content of 5%. Calculate the amount of water required to be added to 5 m³ of soil to raise the water content to 14%. Assume the void ratio to remain constant. Also, find the degree of saturation. Assume $G = 2.65$.

Ans: Refer Q. 1.14, Page 1-16A, Unit-1.

- b. Determine the neutral and effective stress at a depth of 15 m below the ground surface for following conditions :
Water table 3 m below ground surface, for the soil with properties given by specific gravity = 2.65, $e = 0.7$, average moisture content above water table = 5%.

Ans:

Given : Water table depth = 3 m, Specific gravity, $G = 2.65$, Void ratio, $e = 0.7$, Average moisture content above water table, $w = 5\%$
To Find : Neutral and effective stress at a depth 15 m.

1. Degree of saturation is given by,

$$S_e = wG$$

$$S = \frac{wG}{e} = \frac{0.05 \times 2.65}{0.7} = 0.189$$

2. Bulk unit weight,

$$\gamma = \left(\frac{G + S_e}{1 + e} \right) \gamma_w = \left(\frac{2.65 + 0.189 \times 0.7}{1 + 0.7} \right) \times 9.81 = 16.055 \text{ kN/m}^3$$

3. Saturated unit weight,

$$\gamma_{sat} = \left(\frac{G + e}{1 + e} \right) \gamma_w = \left(\frac{2.65 + 0.7}{1 + 0.7} \right) \times 9.81 = 19.33 \text{ kN/m}^3$$

4. Total stress at 15 m depth,

$$\sigma = 16.055 \times 3 + 19.33 \times 12 = 280.125 \text{ kN/m}^2$$

5. Neutral stress at 15 m depth, $u = 19.33 \times 12 = 231.96 \text{ kN/m}^2$

6. Effective stress at 15 m depth,
 $\sigma' = \sigma - u = 280.125 - 231.96 = 48.165 \text{ kN/m}^2$

- c. Define the following terms :

- i. Coefficient of compressibility, ii. Compression index.

- iii. Coefficient of volume change.

- iv. Expansion/ swelling index. v. Recompression index.

Ans: Refer Q. 3.14, Page 2-15A, Unit-3.

- d. Analyze the Skempton's pore pressure coefficients. Describe how are the pore pressure parameters A and B determined ?

Ans: Refer Q. 4.23, Page 4-24A, Unit-4.

- e. Differentiate critically the earth pressure theories of Rankine and Coulomb.

Ans: Refer Q. 5.7, Page 5-10A, Unit-5.

3. Attempt any one part of the following :
a. Differentiate between :
i. Liquidity index and consistency index.
ii. Flow index and toughness index.
iii. Plasticity and consistency.
iv. Activity and sensitivity.

(1 × 10 = 10)

- Ans:
1. Difference between Liquidity Index and Consistency Index:

S.No.	Liquidity Index	Consistency Index
1.	It is defined as the ratio of the difference between the natural water content of the soil and its plastic limit to its plasticity index.	It is defined as the ratio of the difference between the liquid limit and the natural water content of a soil to its plasticity index.
2.	Liquidity index indicates the nearness of its water content to its liquid limit.	Consistency index indicates the consistency of a soil. It shows the nearness of the water content of a soil to its plastic limit.
3.	It is expressed as : $I_L = \frac{w - w_p}{I_p} \times 100$	It is given by, $I_c = \frac{w_L - w}{I_p} \times 100$

- ii. Difference between Flow Index and Toughness Index :

S.No.	Flow Index	Toughness Index
1.	Flow index is the slope of the flow curve obtained between the number of blows and the water content in Casagrande's method of determination of the liquid limit.	Toughness index of a soil is defined as the ratio of the plasticity index to the flow index.
2.	It is the rate at which a soil mass loses its shear strength with an increases in water content.	It is a measure of the shearing strength of the soil at the plastic limit.
3.	It is expressed as : $I_f = \frac{w_1 - w_2}{\log_{10} (N_2 / N_1)}$	It is given by, $I_c = \frac{I_p}{I_f}$

- iii. Difference between Plasticity and Consistency :

S.No.	Plasticity	Consistency
1.	The plasticity of a soil is its ability to undergo deformation without cracking and fracturing.	The consistency of a fine grained soil is the physical state in which it exists.
2.	A plastic soil can be molded into various shapes when it is wet.	It is used to denote the degree of firmness such as soft, firm or hard.

iv. **Difference between Activity and Sensitivity :** Refer Q. 1.18, 2 Marks Questions, Page SQ-4A, Unit-1.

b. Write the importance of the classification of soils ? Discuss in brief with the help of a neat sketch classification of fine-grained soils as per Indian Standard Classification System of soils. Also, give the significance of D_{10} , D_{30} and D_{60} .
Importance : The purpose of soil classification is to arrange various types of soil into groups according to their engineering or agricultural properties and various other characteristics.
Classification : Refer Q. 1.30, Page 1-30A, Unit-1.

Significance :
 D_{10} is the size of sieve hole in which 10% of soil will pass through them.
 D_{30} is the size of sieve hole in which 30% of soil will pass through them.
 D_{60} is the size of sieve hole in which 60% of soil will pass through them.
 D_{10} , D_{30} and D_{60} is used for find Coefficient of uniformity (C_u) and coefficient of curvature (C_c).
 $C_u = D_{60}/D_{10}$
 $C_c = (D_{30})^2 / (D_{60} \times D_{10})$

where, C_u represents particle size distribution.
 C_c represents shape of particles along with the distribution.
 Attempt any one part of the following: (1 x 10 = 10)

a. A falling head permeability test was performed on a sample of a clear uniform sand. One minute was required for the initial head of 100 cm to fall to 50 cm in the standpipe of cross-sectional area of 1.50 cm². If the sample was 4 cm diameter and 30 cm long, calculate the coefficient of permeability of sand.

Ans:

Given : Initial head = 100 cm, Final head = 50 cm, Area of stand pipe, $a = 1.50 \text{ cm}^2$, Diameter of soil sample, $d = 4 \text{ cm}$, Time = 1 min = 60 sec, Length of soil sample, $L = 30 \text{ cm}$
To Find : Coefficient of permeability.

1. Coefficient of permeability is given by,

$$k = \frac{aL}{A(t_2 - t_1)} \ln \left(\frac{h_1}{h_2} \right) = \frac{1.5 \times 30}{\pi \times 4^2 \times 60} \ln \left(\frac{100}{50} \right) = 2.482 \text{ cm/min}$$

$h = 0.41367 \text{ mm/sec}$

b. Explain quick sand condition. Give the expression for critical hydraulic gradient along with its significance.
Quick Sand Condition : Refer Q. 2.21, Page 2-26A, Unit-2.
Significance : The critical hydraulic gradient is used to characterize the seepage stability of soil samples, related to soil porosity and density. Critical hydraulic gradient is defined by the hydraulic gradient where particles start to outflow from soil samples.

5. Attempt any one part of the following: (1 x 10 = 10)
 a. Illustrate the assumptions of the Terzaghi's theory for calculating the rate of 1-D consolidation and prove that :

$$\frac{\partial u}{\partial t} = c_v \cdot \frac{\partial^2 u}{\partial z^2}$$

Ans: Refer Q. 3.12, Page 3-12A, Unit-3.

b. Compare standard Proctor test and modified Proctor test.
Ans: Comparison of Standard Proctor Test and Modified Proctor Test :

S.No.	Standard Proctor Test	Modified Proctor Test
1.	It is a light compaction test.	It is a heavy compaction test.
2.	Number of layer is 3.	Number of layer is 5.
3.	Height of free fall 304.8 mm (12").	Height of free fall 457.2 mm (18").
4.	Weight of hammer is 2.495 kg.	Weight of hammer is 4.54 kg.
5.	Number of blow per layer is 25.	Number of blow per layer is 25.
6.	Volume of mould is 942 cc.	Volume of mould is 942 cc.
7.	Energy imported per unit volume is 605160 N-mm/m ³	Energy imported per unit volume is 272600 N-mm/m ³

6. Attempt any one part of the following: (1 x 10 = 10)
 a. Discuss in detail the Mohr-Coulomb's theory of shear failure of soils.

Ans: Refer Q. 4.14, Page 4-14A, Unit-4.

b. Describe tri-axial shear test. What are its advantages and disadvantages ?

Ans: Triaxial Shear Test : Refer Q. 4.16, Page 4-20A, Unit-4.
 Advantages and Disadvantages : Refer Q. 4.19, Page 4-22A, Unit-4.

7. Attempt any one part of the following: (1 x 10 = 10)
 a. What are the basic mode of failure of an earth retaining structure ? Briefly, outline the remedial measures that can be undertaken against such failures ?

Ans. Types of Failure Modes :

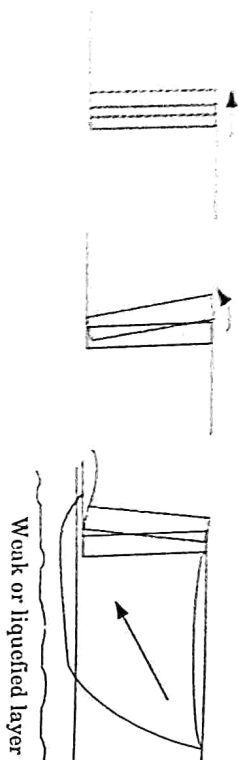

Fig. 1.

- Gravity walls usually fail by rigid-body mechanisms such as sliding and/or overturning or by gross instability:
 - Sliding occurs when horizontal force equilibrium is not maintained (*i.e.*, when the lateral pressures on the back of the wall produce a thrust that exceeds the available sliding resistance on the base of the wall).
 - Overturning failures occur when moment equilibrium is not satisfied; bearing failures at the base of the wall are often involved.
 - Gravity walls may also be damaged by gross instability of the soils behind and beneath them. Such failures may be treated as slope stability failures that encompass the wall.
- Composite wall systems, such as crib walls, bin walls, and mechanically stabilized walls, can fail in the same ways or by a number of internal mechanisms that may involve shearing, pullout, or tensile failure of various wall elements.

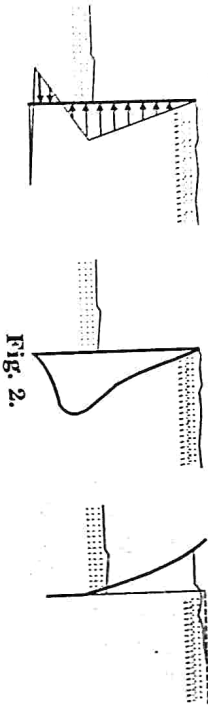

Fig. 2.

- For Cantilever Wall :**
 - Cantilever walls are subject to the same failure mechanisms as gravity walls, and also to flexural failure mechanisms.
 - Soil pressures and bending moments in cantilever walls depend on the geometry, stiffness, and strength of the wall-soil system.
 - If the bending moments required for equilibrium exceed the flexural strength of the wall, flexural failure may occur.
 - The structural ductility of the wall itself may influence the level of deformation produced by flexural failure.

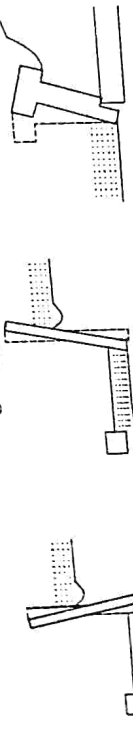

Fig. 3.

- For Braced Walls :**
 - Braced walls usually fail by gross instability; tilting, flexural failure, and/or failure of bracing elements.
 - Tilting of braced walls typically involves rotation about the point at which the brace acts on the wall, often the top of the wall as in the cases of basement and bridge abutment walls.
- For Anchored Walls :** Anchored walls with inadequate cantilever walls, anchored walls may fail in flexure. As in the case of point of failure (maximum bending moment) is likely to be different.
- Preventive Measures :** Following are the common preventive measures :
 - Redeem Surface Drainage Problems :** To prevent accumulating water at the back face of the wall by re-grading backfill material surface or constructing small concrete culvert to divert water and direct it away from backfill also number of weep holes might be another mitigation strategy.
 - Reduce Retaining Wall Height :** Decreasing retain earth height by re-grading backfill earth surface, and landscape changing or pressing down drainage culvert at the wall back face.
 - Extend Footing :** Footing toe extension decrease soil bearing pressure significantly. The soil is excavated and concrete is poured after the required amount of extension is determined and the footing could be depending for a key if required.
 - Use Tie Back :** It can be used as mitigation method for situation that stem wall observed extremely overstressed. Holes are drilled at the back of the wall and tie back is installed that exceeds the backfill failure plane.
 - Remove and Replace Backfill Materials :** This solution is employed when backfill soil is saturated and cannot be mitigated from the surface crush rock is a choice that might be used to replace backfill earth and well-functioning of drainage at wall base should be assured.
 - Add a Key :** Deepened key provision in front of the existing footing may solve retaining wall sliding problems and increase passive resistance.
 - Push it Back to Plump :** This method is not advised but it is feasible to carry out when the wall lean out is around 2.5 cm or 5 cm. The likelihood of executing this technique successfully related to certain conditions for example backfill material has not been placed, retaining wall height and with the above fixes.
 - Use Cantilevered Soldier Beam :** Soldier beams are in the hole that are drilled on the footing heel and tied to the wall to transfer loads. The beams are spaced at specified distance along the horizontal span of the wall.
- A 5 m high rigid retaining wall has to retain the soil having the following properties :
 $G = 2.68$, $\mu = 0.36$, $c = 0.74$ and $\phi = 30^\circ$

- i. Plot the distribution of lateral earth pressure for the wall.
- ii. Determine the magnitude and point of resultant thrust if the
- iii. Compute the percentage change in lateral thrust if the water table rises from a great depth to the top of the backfill.

Ans.

Given : Height of wall, $H = 5\text{ m}$, $G = 2.68$, $\mu = 0.36$, $e = 0.74$, $\phi = 30^\circ$
 To Find : Magnitude and point of resultant thrust, Percentage change in lateral thrust and plot the distribution of lateral pressure.

1. Saturated unit weight,

$$\gamma_{\text{sat}} = \left(\frac{G+e}{1+e} \right) \gamma_w = \left(\frac{2.68+0.74}{1+0.74} \right) \times 9.81 = 19.282 \text{ kN/m}^3$$

2. Coefficient of earth pressure,

$$k_a = \frac{1 - \sin \phi}{1 + \sin \phi} = \frac{1 - \sin 30^\circ}{1 + \sin 30^\circ} = \frac{1}{3}$$

3. At top,

$$P_a = k_a \gamma H = \frac{1}{3} \times 19.282 \times 0 = 0$$

4. At bottom,

$$P_a = k_a \gamma H = \frac{1}{3} \times 19.282 \times 5 = 32.1367 \text{ kN/m}^2$$

5. Lateral thrust, $= \frac{1}{2} \times P_a \times H = \frac{1}{2} \times 32.1367 \times 5 = 80.342 \text{ kN/m}$

Point of Application :

$$\frac{H}{3} = \frac{5}{3} \text{ (from base)}$$

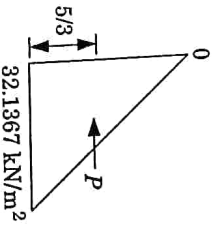

Fig. 4.

6. When water table is at top :

Submerge unit weight,

$$\gamma' = \gamma_{\text{sat}} - \gamma_w = 19.282 - 9.81 = 9.472 \text{ kN/m}^3$$

At bottom, $P_a = k_a \gamma' H = \frac{1}{3} \times 9.472 \times 5 = 64.8367 \text{ kN/m}^2$

Lateral thrust, $P = \frac{1}{2} \times P_a \times H = \frac{1}{2} \times 64.8367 \times 5 = 162.09167 \text{ kN/m}$

7. Percentage change in thrust = $\frac{162.09167 - 80.342}{80.342} \times 100 = 101.75\%$

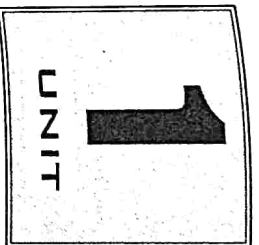

Origin and Classification of Soil (Multiple Choice Questions)

1. The engineering of soil is not related to the design of :
 - A. Foundation
 - B. Pavement
 - C. Earth dam
 - D. Ropeway

Explanation : Refer Q. 1.1, Page 1-2A, Unit-1.
2. Residual soils are formed by :
 - a. Weathering of rocks, acted upon by the forces of transportation.
 - b. Weathering of rocks, not acted upon by the forces of transportation.

Which statement is true ?

 - A. Statement (a)
 - B. Statement (b)
 - C. Both statements (a) and (b)
 - D. None of the above

Explanation : Refer Q. 1.2, Page 1-2A, Unit-1.
3. The soils which are transported by the running waters are called :
 - i. Alluvial soils
 - ii. Aeolian soils
 - iii. Marine soils
 - iv. Lacustrine soils

Explanation : Refer Q. 1.3, Page 1-3A, Unit-1.
4. Lacustrine soils are connected with :
 - i. Lakes
 - ii. Glaciers
 - iii. Wind
 - iv. Oceans

Explanation : Refer Q. 1.3, Page 1-3A, Unit-1.
5. The soils which are transported by the wind are called :
 - i. Aeolian soils
 - ii. Alluvial soils
 - iii. Marine soils
 - iv. Lacustrine soil

Explanation : Refer Q. 1.3, Page 1-3A, Unit-1.
6. Which one of the following soils is formed by wind :
 - i. Talus
 - ii. Loess
 - iii. Drift
 - iv. Marl

Explanation : Refer Q. 1.3, Page 1-3A, Unit-1.
7. The soils which is transported by the moving ice is called :
 - A. Residual soil
 - B. Glacial soil
 - C. Marine soil
 - D. Aeolian soil

Explanation : Refer Q. 1.3, Page 1-3A, Unit-1.

MCQ-2A (CE-Sem-5)

Multiple Choice Questions

8. Gravity deposited soils are called :
 A. Drift
 B. Loess
 C. Talus
 D. None of the above
Explanation : Refer Q. 1.3, Page 1-3A, Unit-1.

9. When the voids of a soil mass are filled with water only, the soil is known as :
 A. Partially saturated soil
 B. Saturated soil
 C. Dry soil
 D. None of the above
Explanation : Refer Q. 1.6, Page 1-4A, Unit-1.

10. If the voids of a soil mass are full of air only, the soil is termed as :
 A. Air entrained soil
 B. Partially saturated soil
 C. Dry soil
 D. Saturated soil
Explanation : Refer Q. 1.6, Page 1-4A, Unit-1.

11. Which condition of the soil Fig. 1 shows :



Fig. 1.

- A. Actual soil mass
 B. Soil mass by three phase condition
 C. Dry soil
 D. Saturated soil
Explanation : Refer Q. 1.6, Page 1-4A, Unit-1.

12. The ratio of volume of voids to volume of soil solid is called :
 A. Void ratio
 B. Porosity
 C. Degree of saturation
 D. Water content
Explanation : Refer Q. 1.7, Page 1-5A, Unit-1.

13. The ratio of volume of voids to the total volume of the soil mass is called :
 A. Air content
 B. Porosity
 C. Void ratio
 D. All of the above
Explanation : Refer Q. 1.7, Page 1-5A, Unit-1.

14. The ratio of the volume of water present in a given soil mass to the total volume voids, is known as :
 A. Void ratio
 B. Porosity
 C. Degree of saturation
 D. Percentage voids
Explanation : Refer Q. 1.7, Page 1-5A, Unit-1.

15. Valid range for the degree of saturation of soil(s), in percentage, is :

Geotechnical Engineering

MCQ-3A (CE-Sem-5)

- A. $S > 0$
 B. $S \leq 0$
 C. $0 < S < 100$
 D. $0 \leq S \leq 100$
Explanation : Refer Q. 1.7, Page 1-5A, Unit-1.

16. What is the ratio of volume of air voids to the volume of total voids in the soil mass ?
 A. Air content
 B. Porosity
 C. Void ratio
 D. Percentage air voids
Explanation : Refer Q. 1.7, Page 1-5A, Unit-1.

17. The water content in the soil is :
 A. Ratio of volume of water to volume of soil.
 B. Ratio of volume of water to volume of solids.
 C. Ratio of weight of water to volume of soil.
 D. Ratio of weight of water to weight of solids.
Explanation : Refer Q. 1.7, Page 1-5A, Unit-1.

18. Water content of soil can :
 A. Take values only from 0 % to 100 %
 B. Be less than 0 %
 C. Never be greater than 100 %
 D. Be greater than 100 %
Explanation : Refer Q. 1.7, Page 1-5A, Unit-1.

19. The relationship between void ratio 'e' and porosity 'n' is :
 A. $n = \frac{e}{1+e}$
 B. $e = \frac{1+n}{1-e}$
 C. $n = \frac{1+e}{1-e}$
 D. $e = n(1+e)$
Explanation : Refer Q. 1.8, Page 1-7A, Unit-1.

20. The relation between e, S, w, and G is given by :
 A. $e = \frac{wG}{S}$
 B. $w = \frac{Ge}{S}$
 C. $G = \frac{ew}{S}$
 D. $S = \frac{ew}{G}$
Explanation : Refer Q. 1.8, Page 1-7A, Unit-1.

21. The relationship between air content of soil and its degree of saturation S is expressed as :
 A. $a_c = 1 + S$
 B. $a_c = S - 1$
 C. $a_c = 1 - S$
 D. None of these
Explanation : Refer Q. 1.8, Page 1-7A, Unit-1.

22. If void ratio is 0.7, water content is 0.188 and specific gravity is 2.68, then degree of saturation of soil is :
 A. 25 %
 B. 40 %
 C. 75 %
 D. 60 %

MCQ-4A (CE-Sem-5)

Multiple Choice Questions

Explanation : Refer Q. 1.8, Page 1-7A, Unit-1.

23. Which are of the following method is most accurate for the determination of the water content of soil ?
 A. Oven drying method
 B. Sand bath method
 C. Calcium carbide method
 D. Pycnometer method
 Explanation : Refer Q. 1.9, Page 1-10A, Unit-1.

24. An octahedral unit has :
 A. Four negative charges
 B. Three negative charges
 C. One negative charge
 D. No negative charge
 Explanation : Refer Q. 1.20, Page 1-20A, Unit-1.

25. The correct sequence of plasticity of minerals in soil in an increasing order is :
 A. Silica, Kaolinite, Illite, Montmorillonite
 B. Kaolinite, Silica, Illite, Montmorillonite
 C. Silica, Kaolinite, Montmorillonite, Illite
 D. Kaolinite, Silica, Montmorillonite, Illite
 Explanation : Refer Q. 1.21, Page 1-21A, Unit-1.

26. The predominant mineral responsible for shrinkage and swelling in black cotton soil is :
 A. Illite
 B. Kaolinite
 C. Mica
 D. Montmorillonite
 Explanation : Refer Q. 1.21, Page 1-21A, Unit-1.

27. Consider the following clay minerals :
 (1) Kaolinite, (2) Illite, (3) Montmorillonite
 Which one of the following is the correct sequence of the minerals given above in the increasing order of their grain size ?
 A. 3-2-1
 B. 1-3-2
 C. 1-2-3
 D. 3-1-2
 Explanation : Refer Q. 1.21, Page 1-21A, Unit-1.

28. As per IS classification of particle sizes, the sieve analysis is performed on a soil to determine the particle size distribution of particles in the range of :
 A. 0.075 mm and above
 B. 0.075 mm and below
 C. between 4.75 mm to 0.075 mm
 D. 4.75 mm and above
 Explanation : Refer Q. 1.23, Page 1-24A, Unit-1.

29. The sedimentation analysis is performed on a soil to determine the particle size distribution of particles in the range of :
 A. Silt size range only
 B. Both silt and clay size range
 C. Sand size only
 D. both sand and silt size range
 Explanation : Refer Q. 1.24, Page 1-25A, Unit-1.

Geotechnical Engineering

MCQ-5A (CE-Sem-5)

30. Stoke's law is valid for particles falling in size range of :
 A. Less than 0.0002 mm
 B. Between 0.2 mm to 0.0002 mm
 C. Greater than 0.2 mm
 D. All of the above
 Explanation : Refer Q. 1.24, Page 1-25A, Unit-1.

31. In hydrometer analysis for a soil mass :
 A. Both meniscus correction and dispersing agent correction are additive
 B. Meniscus correction is additive and dispersing agent correction is subtractive
 C. Both meniscus correction and dispersing agent correction are subtractive
 D. Meniscus correction is subtractive and dispersing agent correction is additive.
 Explanation : Refer Q. 1.25, Page 1-26A, Unit-1.

32. Choose the incorrect pair :
 A. Effective diameter of grain - D_{10}
 B. Uniformity coefficient - D_{60}/D_{10}
 C. Coefficient of curvature - $D_{30}^2 / (D_{10} \times D_{60})$
 D. Coefficient of permeability - D_{30}^2
 Explanation : Refer Q. 1.27, Page 1-27A, Unit-1.

33. Consider the following :
 1. The gain in strength of the soil with passage of time after it has been remoulded is called thixotropy.
 2. It is mainly due to a gradual reorientation of molecules of water in the adsorbed water layer and due to reestablishment of chemical equilibrium.
 Which of these statements are correct ?
 A. Only 1
 B. Only 2
 C. Both 1 and 2
 D. None of these
 Explanation : Refer Q. 1.29, Page 1-29A, Unit-1.

34. Consider the following statements regarding the compressibility of silt and clays.
 1. Low compressibility if liquid limit is less than 35.
 2. Medium compressibility if liquid limit is greater than 35 and less than 50.
 3. High compressibility if liquid is greater than 50.
 Which of these statements are correct ?
 A. 1 and 2 are correct
 B. 2 and 3 are correct
 C. 1 and 3 are correct
 D. 1, 2 and 3 are correct
 Explanation : Refer Q. 1.30, Page 1-30A, Unit-1.

35. The liquidity index is defined as a ratio expressed as percentage of :
 A. Plastic limit minus the natural water content to its plasticity index

- B. Natural water content minus its plastic limit to its plasticity index
 C. Natural water content plus its plastic limit to its plasticity index
 D. Liquid limit minus the natural water content to the plasticity index
Explanation : Refer Q. 1.30, Page 1-30A, Unit-1.

36. The water content of a soil which represents the boundary between plastic state and liquid state is known as :
 A. Liquid limit
 B. Plastic limit
 C. Shrinkage limit
 D. Plasticity index
Explanation : Refer Q. 1.30, Page 1-30A, Unit-1.

37. Liquidity index of a soil is given by :
 A. $\frac{w - w_p}{w_l - w_p}$
 B. $\frac{w_l - w}{w_l - w_p}$
 C. $\frac{w_l - w_p}{w - w_p}$
 D. $\frac{w_l - w_p}{w - w_p}$
Explanation : Refer Q. 1.31 Page 1-31A, Unit-1.

38. The liquid limit and plastic limit of a cohesive soil are determined in laboratory as 64 % and 34 % respectively. The plasticity index of the soil will be :
 A. 10 %
 B. 30 %
 C. 30 %
 D. 40 %
Explanation : Refer Q. 1.31, Page 1-31A, Unit-1.

39. Match List I with List II and select the correct answer using to codes given below :
List I (Soil)
 (a) Clay
 (b) Coarse sand
 (c) Fine sand
 (d) Silt
List II (Grain size)
 (1) 2.00 to 4.75 mm
 (2) 0.002 to 0.075 mm
 (3) 0.075 to 0.425 mm
 (4) Less than 0.002 mm
Codes :
- | | | | |
|-----|-----|-----|-----|
| (a) | (b) | (c) | (d) |
| 1 | 3 | 4 | 2 |
| 2 | 1 | 3 | 4 |
| 3 | 1 | 3 | 2 |
| 4 | 1 | 3 | 2 |
- Explanation :** Refer Q. 1.34, Page 1-33A, Unit-1.

40. What is grain size of cobble soil particle ?
 A. 20 mm to 300 mm
 B. 4.75 mm to 20 mm
 C. 4.75 mm to 80 mm
 D. 80 mm to 300 mm
Explanation : Refer Q. 1.34, Page 1-33A, Unit-1.



Soil Hydraulics
 (Multiple Choice Questions)

1. Effective stress may be defined as :
 A. Effective stress = Total stress - pore water pressure
 B. Effective stress = Total stress + pore water pressure
 C. Effective stress = Total stress x pore water pressure
 D. Effective stress = Total stress / pore water pressure
Explanation : Refer Q. 2.1, Page 2-2A, Unit-2.
2. If the water table rises up the ground surface, then the :
 A. Effective stress is reduced due to increase in pore water pressure, but total stress does not change.
 B. Effective stress is reduced due to decrease in total stress but pore water pressure does not change.
 C. Total stress is increased due to decrease in pore water pressure but effective stress does not change.
 D. Total stress is reduced due to increase in pore water pressure but effective stress does not change.
Explanation : Refer Q. 2.1, Page 2-12A, Unit-2.
3. The total and effective stress at a depth of 8 m below the water surface line in a swimming pool, are respective given as :
 A. 78.5 kN/m² and zero
 B. Zero and zero
 C. 78.5 kN/m² and 78.5 kN/m²
 D. None of the above.
Explanation : Refer Q. 2.2, Page 2-2A, Unit-2.
4. The Darcy's law states as :
 A. $v = kA$
 B. $v = kQ$
 C. $v = kh$
 D. $v = ki$
Explanation : Refer Q. 2.7, Page 2-8A, Unit-2.
5. Darcy's law is valid only if the flow is :
 A. Turbulent
 B. Intermitent
 C. Laminar
 D. None of these
Explanation : Refer Q. 2.7, Page 2-8A, Unit-2.
6. The maximum size of particle for which Darcy's law is applicable is :
 A. 0.2 mm
 B. 0.5 mm
 C. 1.0 mm
 D. 2.0 mm

MCQ-8A (CE-Sem-5)

Multiple Choice Questions

Explanation : Refer Q. 2.7, Page 2-8A, Unit-2.

7. The law used in permeability test is :
 A. Stoke's law
 B. Pascal's law
 C. Darcy's law
 D. Newton's law

Explanation : Refer Q. 2.7, Page 2-8A, Unit-2.

8. The property of soil by virtue of which water can flow through its interconnecting voids is known as :
 A. Porosity
 B. Void ratio
 C. Seepage
 D. Permeability

Explanation : Refer Q. 2.8, Page 2-9A, Unit-2.

9. The permeability of clayey soil is best determined by using :
 A. Falling head permeameter
 B. Constant head permeameter
 C. Oedometer
 D. None of these

Explanation : Refer Q. 2.8, Page 2-9A, Unit-1.

10. In a falling head permeability test on a soil. The time taken for the head to fall from h_0 to h_1 is 't'. The test is repeated with same initial head h_0 , the final head h' is noted in time $t/2$, which one of the following equations gives the relation between h' , h_0 and h_1 ?

- A. $h' = h_0/h_1$
 B. $h' = \sqrt{h_0/h_1}$
 C. $h' = h_0^2/h_1$
 D. $h' = \sqrt{h_0 h_1}$

Explanation : Refer Q. 2.8, Page 2-9A, Unit-2.

11. Consider the following statements regarding the coefficient of the permeability of soil :

1. For course-grained soil, the constant head permeability test is performed.
 2. For fine grained soil, the falling head permeability test is performed of these statements :
 A. 1 alone is correct
 B. 2 alone is correct
 C. 1 and 2 both correct
 D. 1 correct and 2 incorrect

Explanation : Refer Q. 2.8, Page 2-9A, Unit-2.

12. What is the unit of permeability ?
 A. cm,
 B. cm^2
 C. mm/sec
 D. None of these

Explanation : Refer Q. 2.9, Page 2-11A, Unit-2.

13. The average coefficient of permeability in natural stratified deposits parallel to stratification is :
 A. Always more than that perpendicular to stratification.
 B. Always less than that perpendicular to stratification.
 C. Always the same as in perpendicular to stratification.
 D. Sometimes more and sometime less than that in perpendicular direction depending upon the soil type.

Explanation : Refer Q. 2.10, Page 2-12A, Unit-2.

Geotechnical Engineering

MCQ-9A (CE-Sem-5)

14. If k_H and k_v are the permeability of a homogeneous but non isotropic soil, in horizontal and vertical direction respectively, then the equivalent isotropic permeability shall be given by,

- A. $\sqrt{k_H k_v}$
 B. $\sqrt{\frac{k_H}{k_v}}$
 C. $\sqrt{\frac{k_v}{k_H}}$
 D. $k_H k_v$

Explanation : Refer Q. 2.10, Page 2-12A, Unit-2.

15. If there is flow from a soil of permeability k_1 to that k_2 , the angle θ_1 and θ_2 , which the flow line makes with normal to the interface are related as :

- A. $\frac{\sin \theta_1}{\sin \theta_2} = \frac{k_1}{k_2}$
 B. $\frac{\tan \theta_1}{\tan \theta_2} = \frac{k_1}{k_2}$
 C. $\frac{\cos \theta_1}{\cos \theta_2} = \frac{k_1}{k_2}$
 D. $\frac{\cot \theta_1}{\cot \theta_2} = \frac{k_1}{k_2}$

Explanation : Refer Q. 2.11, Page 2-13A, Unit-2.

16. An overall value of the coefficient of permeability of a soil deposit for a large area in the field may be determined by

- A. Constant head permeability test
 B. Variable head permeability test
 C. Pumping out test
 D. None of these

Explanation : Refer Q. 2.13, Page 2-15A, Unit-2.

17. The permeability of a given soil is

- A. Directly proportional to the average grain size
 B. Inversely proportional to the average grain size
 C. Directly proportional to the square of the average grain size
 D. Inversely proportional to the square of the average grain size

Explanation : Refer Q. 2.14, Page 2-19A, Unit-2.

18. Physical quality which affects permeability is/are
 A. Only unit weight
 B. Degree of saturation
 C. Only viscosity
 D. Both viscosity and unit weight

Explanation : Refer Q. 2.14, Page 2-19A, Unit-2.

19. Consider the following statements :
 (1) Viscosity decreases the permeability of soil.
 (2) Entrapped air decreases the permeability of soil.
 Which of these statements is/are correct ?

- A. 1 only
 B. 2 only
 C. Both 1 and 2
 D. None of the above

Explanation : Refer Q. 2.14, Page 2-19A, Unit-2.

20. The coefficient of permeability of a soil
 A. Increase with an increase in temperature.
 B. Increase with a decrease in temperature.

Multiple Choice Questions

MCQ-10 A (CE-Sem-5)

- C. Increase with an increase in unit weight of water.
 D. Decrease with an increase in void ratio.
Explanation : Refer Q. 2.14, Page 2-19A, Unit-2.
21. Consider the following statements about the properties of flow nets :
Explanation : Refer Q. 2.15, Page 2-20A, Unit-2.
- Flow lines are perpendicular to equipotential lines.
 - No two flow lines or equipotential lines start from the same point.
 - No two flow lines cross each other.
 - No two flow lines are correct
- A. 1, 2 and 3 are correct
 B. 2 and 3 are correct
 C. 1 and 2 are correct
 D. 1 and 3 are correct
Explanation : Refer Q. 2.15, Page 2-20A, Unit-2.
22. For isotropic medium soil, the shape of flow fields :
 A. Circular
 B. Rectangular
 C. Square
 D. Trapezoidal
Explanation : Refer Q. 2.15, Page 2-20A, Unit-2.
23. Consider the following statement about the characteristic of flow net :
Explanation : Refer Q. 2.15, Page 2-20A, Unit-2.
- Loss of head between two equipotential lines is always same and is termed as equipotential drop.
 - The area between the flow lines is known as flow channel and discharge through each flow channel is same.
 - Only 2 is correct
 - Neither 1 or nor 2 is correct
- A. Only 1 is correct
 B. Only 2 is correct
 C. Both 1 and 2 are correct
 D. Neither 1 or nor 2 is correct
Explanation : Refer Q. 2.15, Page 2-20A, Unit-2.
24. A flow net is drawn to obtain :
 A. Seepage, coefficient of permeability and uplift pressure.
 B. Exit gradient, uplift pressure and seepage quantity.
 C. Coefficient of permeability, uplift pressure and exit gradient.
 D. Exit gradient, seepage and coefficient of permeability.
Explanation : Refer Q. 2.16, Page 2-21A, Unit-2.
25. The total discharge per unit time through a flow net is given by :
 A. $q = kH \frac{N_f}{N_d}$
 B. $q = \frac{k N_f}{H N_d}$
 C. $q = kH \frac{N_d}{N_f}$
 D. $q = \frac{k N_d}{H N_f}$
Explanation : Refer Q. 2.17, Page 2-21A, Unit-2.
26. If the flownet of a coffer dam foundation had six numbers of flow channels and sixteen numbers of equipotential drops, with the head of water lost during seepage being 6 m through the foundation having $k = 4 \times 10^{-5}$ m/min. The seepage loss (in m³/day) per meter length of the dam will be _____
 A. 2.16×10^{-3}
 B. 6.48×10^{-3}
 C. 12.96×10^{-2}
 D. 25.92×10^{-2}
Explanation : Refer Q. 2.17, Page 2-21A, Unit-2.

Geotechnical Engineering

MCQ-11 A (CE-Sem-5)

27. What is/are the assumptions made for deriving the Laplace equation ?
 A. The flow is two dimensional
 B. Soil is isotropic and homogeneous
 C. The flow is steady and incompressible
 D. All of the above
Explanation : Refer Q. 2.18, Page 2-22A, Unit-2.
28. Which of the following constitutes the limitations of Dupuit's theory ?
 A. An aquifer is not fully homogeneous
 B. Permeability may not be uniform
 C. The equilibrium conditions might have not fully reached.
 D. All of the above
Explanation : Refer Q. 2.19, Page 2-24A, Unit-2.
29. Which of the following is / are assumption(s) of Dupuit's theory ?
 A. The flow is laminar and Darcy's law is valid.
 B. The coefficient of permeability remains constant throughout.
 C. Flow towards the well is radial and horizontal.
 D. All of the above
Explanation : Refer Q. 2.19, Page 2-24A, Unit-2.
30. Quick sand is
 A. A type of sand
 B. A condition in which a cohesionless soil loses its strength because of upward flow of water.
 C. A condition in which a cohesive soil loses its strength
 D. A condition which may occur in dry sand
Explanation : Refer Q. 2.21, Page 2-26A, Unit-2.
31. A deposit of fine sand has a void ratio e and specific gravity of soil solid is G . The hydraulic gradient of the deposit to develop boiling condition of sand is given by,
 A. $i_c = (G - 1) (1 - e)$
 B. $i_c = (G - 1) (1 + e)$
 C. $i_c = \frac{G - 1}{1 - e}$
 D. $i_c = \frac{G - 1}{1 + e}$
Explanation : Refer Q. 2.21, Page 2-26A, Unit-2.
32. An upward hydraulic gradient ' i ' of a certain magnitude will initiate the phenomenon of boiling in granular soils. The magnitude of this gradient is
 A. $0 \leq i < 0.5$
 B. $0.5 \leq i < 1.0$
 C. $i = 1.0$
 D. $1 < i \leq 2$
Explanation : Refer Q. 2.21, Page 2-26A, Unit-2.
33. A strata of 3.5 m thick fine sand had void ratio of 0.7 and G of 2.7. For a quick sand condition to develop in these strata the water flowing in upward direction would require a head of _____
 A. 7 m
 B. 5.56 m
 C. 5 m
 D. 3.5 m
Explanation : Refer Q. 2.21, Page 2-26A, Unit-2.

34. The hydraulic gradient at which quick sand condition occurs is termed as-
- Critical gradient
 - Piping gradient
 - Floating gradient
 - All of the above
- Explanation :** Refer Q. 2.21, Page 2-26A, Unit-2.
35. The capillary pressure in soil causes :
- Apparent cohesive strength in clayey soils
 - Bulking of sand
 - Increased intergranular stress in the soil mass
 - All of the above
- Explanation :** Refer Q. 2.22, Page 2-27A, Unit-2.
36. Consider the following :
- Capillary height depends upon the grain size and size of pores.
 - In course grained soils the capillary rise is very small as compare to find grained soil.
- Only 1 is correct
 - Only 2 is correct
 - Both 1 and 2 are correct
 - None of the above
- Explanation :** Refer Q. 2.22, Page 2-27A, Unit-2.
37. The stress which is responsible for retaining water in a capillary tube above the free water surface of the water body in which the capillary tube inserted is called the-
- Capillary compression
 - Capillary tension
 - Capillary pore pressure
 - None of the above
- Explanation :** Refer Q. 2.22, Page 2-27A, Unit-2.
38. Piping in soil occurs when _____
- The soil is highly porous
 - Sudden change in permeability occurs
 - Effective pressure becomes zero
 - The soil is highly stratified
- Explanation :** Refer Q. 2.23, Page 2-27A, Unit-2.
39. The length of the path of percolation can be increased by,
- Increasing the base width of the hydraulic structure.
 - Providing vertical cut off walls below the hydraulic structures.
 - Providing an upstream impervious blanket.
 - All of the above.
- Explanation :** Refer Q. 2.23, Page 2-27A, Unit-2.
40. Consider the following inequalities regarding the filters providing in a dam.
- $\frac{(D_{15})_f}{(D_{85})_s} < 4 - 5$
 - $\frac{(D_{15})_f}{(D_{15})_b} > 4 - 5$
 - $\frac{(D_{25})_f}{(D_{75})_s} < 20$
 - $\frac{(D_{60})_f}{(D_{60})_s} < 25$
- 1 alone is correct
 - 2 and 3 are correct
 - 1, 2 and 4 are correct
 - 3 and 4 are correct
- Explanation :** Refer Q. 2.25, Page 2-29A, Unit-2.

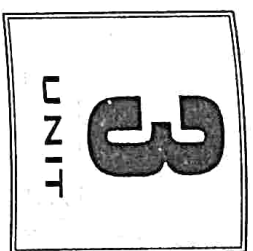

Soil Compaction and Consolidation (Multiple Choice Questions)

- The process by which the soil particles artificially rearranged into a closer state of contact by mechanical means in order to decrease the porosity, is known as -
 - Consolidation
 - Compaction
 - Settlement
 - None of the above

Explanation : Refer Q. 3.1, Page 3-2A, Unit-3.
- By means of compaction the following properties of the soil increase.
 - Mass density
 - Shear strength
 - Stability
 - All of the above

Explanation : Refer Q. 3.1, Page 3-2A, Unit-3.
- Soil compacted dry of the optimum as compared to that wet of the optimum
 - Has less permeability
 - Swell less
 - Shrinks less
 - Has less resistance to compression

Explanation : Refer Q. 3.1, Page 3-2A, Unit-3.
- For cohesive soil with increasing compactive effort the optimum moisture content is
 - Increase
 - Decrease
 - Remain constant
 - Zero

Explanation : Refer Q. 3.2, Page 3-3A, Unit-3.
- In a compaction test if the compacting effort is increased it will result in
 - Increase in maximum dry density and OMC.
 - Increase in maximum dry density but one remains unchanged.
 - Increase in maximum dry density and decrease in OMC.
 - No change in maximum dry density but decrease in OMC.

Explanation : Refer Q. 3.2, Page 3-2A, Unit-3.
- Pneumatic tyred rollers are useful for compacting
 - Cohesive soils
 - Cohesionless soil
 - Both (A) and (B)
 - For soil in a confined space

Explanation : Refer Q. 3.3, Page 3-3A, Unit-3.
- Vibratory roller is best suited for compacting

- A. Coarse sand and gravels
 B. Silts
 C. Clays
 D. Organic soils

Explanation : Refer Q. 3.3, Page 3-3A, Unit-3.

8. Match List I with List II

List I (Types of soil formation) List II (Types of compaction)

- | | |
|-----------------------------|---------------------------|
| a. Cohesive soil | 1. Sheep foot roller |
| b. Moderately cohesive soil | 2. Vibratory roller |
| c. Cohesionless soil | 3. Pneumatic tyred roller |
| d. Crushed stone | 4. Smooth wheeled roller |
| A. 1, 3, 2, 4 | B. 1, 2, 3, 4 |
| C. 1, 4, 3, 2 | D. 1, 3, 4, 2 |

Explanation : Refer Q. 3.3, Page 3-3A, Unit-3.

9. Match List I with List II

List I

List II

- | | |
|--------------------------|--------------------------|
| a. Sheep foot roller | 1. Core of earthen dam |
| b. Smooth wheeled roller | 2. Dry sand |
| c. Pneumatic roller | 3. Casing of earthen dam |
| d. Vibratory roller | 4. Graved in WBM. |
| A. 3, 4, 2, 1 | B. 1, 4, 3, 2 |
| C. 1, 3, 4, 2 | D. 2, 1, 3, 4 |

Explanation : Refer Q. 3.3, Page 3-3A, Unit-3.

10. The basic action involved in sheep foot rolling is :

- A. Kneading
 B. Pressing
 C. Tamping
 D. Vibration

Explanation : Refer Q. 3.3, Page 3-3A, Unit-3.

11. The optimum moisture content of soil is obtained from a plot of

- A. Water content versus compacted unit weight
 B. Dry unit weight versus water content
 C. Time versus compression
 D. Effective stress versus void ratio

Explanation : Refer Q. 3.4, Page 3-5A, Unit-3.

12. Field control of compaction can be achieved by :

- A. Proctor needle method
 B. Core cutter method
 C. Sand replacement method
 D. All of the above

Explanation : Refer Q. 3.4, Page 3-5A, Unit-3.

13. The field compaction control consist of the determination of :

- A. The water content at which the soil has been compacted
 B. The dry density achieved
 C. Both A and B
 D. None of these

Explanation : Refer Q. 3.4, Page 3-4A, Unit-3.

14. For conducting a standard Proctor compaction test, the weight of hammer (P in kg), the fall of hammer (Q in mm) the weight of blows per layer (R), and the number of layer (S) respectively

P	Q	R	S
A. 5.89,	550,	50,	3
B. 4.89,	550,	25,	3
C. 3.60,	310,	35,	4
D. 2.495,	304.8,	25,	3

Explanation : Refer Q. 3.5, Page 3-6A, Unit-3.

15. The ratio of the energies imparted to soil sample in modified Proctor's compaction test and the standard Proctor's compaction test is about _____

- A. 10.0
 B. 4.5
 C. 2.5
 D. 1.8

Explanation : Refer Q. 3.5, Page 3-6A, Unit-3.

16. The line of optimums generally corresponds to percentage air voids of about _____

- A. 0 %
 B. 5 %
 C. 10 %
 D. 100 %

Explanation : Refer Q. 3.5, Page 3-6A, Unit-3.

17. The maximum dry density is given by,

- A. $\gamma_d = \frac{\gamma}{1-w}$
 B. $\gamma_d = \frac{\gamma}{1+w}$
 C. $\gamma_d = \gamma(1-w)$
 D. $\gamma_d = \gamma(1+w)$

Explanation : Refer Q. 3.5, Page 3-6A, Unit-3.

18. Standard Proctor's test is conducted with the following purpose :
 A. To know the optimum moisture content and resulting dry density of soil.
 B. To know the long term settlement of embankments.
 C. To know the shear strength of soil.
 D. To know the CBR value of subgrade soil.

Explanation : Refer Q. 3.5, Page 3-6A, Unit-3.

19. Workout the theoretical maximum dry density for a soil sample having OMC 10 % and bulk unit is equal to 22 kN/m³.

- A. 20 kN/m³
 B. 23.2 kN/m³
 C. 22.0 kN/m³
 D. 21 kN/m³

Explanation : Refer Q. 3.6, Page 3-7A, Unit-3.

20. Consider the following :
 1. The degree of compaction for sand is given by relative density. It

expressed as : $I_D = \frac{e_{max} - e}{e_{max} - e_{min}}$

MCQ-16A (CE-Sem-5)

Multiple Choice Questions

2. Relative compaction is given by, $\frac{\gamma_{d(max)}}{\gamma_{d(max)}}$

- A. 1 is correct
 - B. 2 is correct
 - C. Both 1 and 2 are correct
 - D. Neither 1 nor 2 is correct
- Explanation : Refer Q. 3.8, Page 3-9A, Unit-3.

21. Reduction of soils volume can occur due to :
- A. Compression of solid particles and water in the voids.
 - B. Compression and expulsion of air in the voids.
 - C. Expulsion of water in voids.
 - D. All of the above
- Explanation : Refer Q. 3.9, Page 3-10A, Unit-3.

22. Consolidation can occur due to
- A. External static loads from the structure
 - B. Self weight of the soil such as recently placed fills.
 - C. Lowering the water table and desiccation
 - D. All of the above
- Explanation : Refer Q. 3.10, Page 3-10A, Unit-3.

23. The expulsion of water from the pores of the soil due to steady pressure is known as :
- A. Compaction
 - B. Consolidation
 - C. Shrinkage
 - D. None of the above
- Explanation : Refer Q. 3.10, Page 3-10A, Unit-3.

24. The property of soil mass pertaining to its susceptibility to decrease in volume under pressure is known as :
- A. Compressibility
 - B. Expansion
 - C. Shrinkage
 - D. Compaction
- Explanation : Refer Q. 3.10, Page 3-10A, Unit-3.

25. Reduction in volume of soil primarily due to squeezing out of water from the voids is called :
- A. Primary consolidation
 - B. Plastic flow
 - C. Creep
 - D. Secondary consolidation
- Explanation : Refer Q. 3.11, Page 3-12A, Unit-3.

26. Consider the following :
1. Initial consolidation
 2. Primary consolidation
 3. Secondary consolidation
 4. Final consolidation
- The three stages which would be relevant to consolidation of a soil deposit include :

Geotechnical Engineering

MCQ-17A (CE-Sem-5)

- A. 1, 2 and 3
 - B. 2, 3 and 4
 - C. 1, 3 and 4
 - D. 1, 2 and 4
- Explanation : Refer Q. 3.11, Page 3-12A, Unit-3.

27. Assumption made in the Terzaghi's consolidation theory is :
- A. The soil is homogeneous and fully saturated
 - B. Coefficient of permeability is constant
 - C. Drainage of water occurs only in one direction
 - D. All of the above
- Explanation : Refer Q. 3.12, Page 3-12A, Unit-3.

28. The relation between coefficient of consolidation c_v , the coefficient of volume change m_v , and coefficient of permeability k_v is given by :

A. $C_v = \frac{k}{m_v \gamma_w}$ B. $C_v = \frac{km}{\gamma_w}$

C. $C_v = \frac{\gamma_w}{km}$ D. $C_v = \frac{m \gamma_w}{k}$

Explanation : Refer Q. 3.12, Page 3-12A, Unit-3.

29. A soil which has never been subjected to an effective stress greater than the existing pressure and which is also completely consolidated, is called :
- A. Under-consolidated
 - B. Over consolidated
 - C. Normally consolidated
 - D. None of the above
- Explanation : Refer Q. 3.14, Page 3-15A, Unit-3.

30. Match list I (term) with list II (Definition) and select the correct answer using the codes :

S. No.	List I	List II
(a)	Compression index, C_c	$a_v/1 + e_o$
(b)	Coefficient of volum change, m_v	Slope of e -log $\bar{\sigma}$ curve given by $-\Delta e/\log(\bar{\sigma}/\Delta \bar{\sigma})$
(c)	Coefficient of compressibility, a_v	$h/m_v \gamma_w$
(d)	Coefficient of consolidation, C_v	Slope of the e - σ curve defined as $-\Delta e/\Delta \bar{\sigma}$

- Codes
- | | | | | |
|----|---|---|---|---|
| A. | 2 | 1 | 4 | 3 |
| B. | 4 | 3 | 2 | 1 |
| C. | 2 | 3 | 4 | 1 |
| D. | 4 | 1 | 2 | 3 |
- Explanation : Refer Q. 3.14, Page 3-15A, Unit-3.

MCQ-18 A (CE-Sem-5)

Multiple Choice Questions

31. Coefficient of consolidation is measured in :
 A. cm^2/g
 B. cm^2/sec
 C. $\text{g}/\text{cm}^2/\text{sec}$
 D. $\text{g}/\text{cm}/\text{sec}$
Explanation : Refer Q. 3.15, Page 3-15A, Unit-3.

32. Consolidation time of a sample :
 A. Increase with a decrease in permeability
 B. Increase with an increase in permeability
 C. Increase with a decrease in unit weight of water
 D. Increase with a decrease in compressibility
Explanation : Refer Q. 3.15, Page 3-17A, Unit-3.

33. The relationship between the coefficient of consolidation (c_v) and time factor (T_v) is given by :

A. $T_v = c_v m_v t$

B. $T_v = \frac{d^2}{t}$

C. $T_v = \frac{c_v t}{d^2}$

D. $T_v = \frac{d^2 t}{c_v}$

Explanation : Refer Q. 3.15, Page 3-17A, Unit-3.

34. The ratio of settlement at any time t to the final settlement is known as

- A. Coefficient of consolidation
 B. Compression index
 C. Degree of consolidation
 D. None of above

Explanation : Refer Q. 3.15, Page 3-17A, Unit-3.

35. Coefficient of consolidation of a soil is affected by :

- A. Compressibility
 B. Permeability
 C. Both (A) and (B)
 D. None of the above
Explanation : Refer Q. 3.15, Page 3-17A, Unit-3.

36. Match list I (contact pressure distribution curve) with list II (Description of footings) and select the correct answer using the codes :

List I

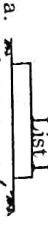

- List II

1. Rigid footing on cohesive soil

2. Flexible footing on cohesive soil

3. Rigid footing on cohesion less soil at ground level

Geotechnical Engineering

MCQ-19 A (CE-Sem-5)



4. Flexible footing on cohesion less soil of ground level

Codes	a	b	c	d
A.	3	1	4	2
B.	4	2	3	1
C.	3	2	4	1
D.	4	1	3	2

Explanation : Refer Q. 3.17, Page 3-19A, Unit-3.

37. The equation for determining the settlement (ΔH) of clayey soil layer of original thickness H_0 existing under an overburden pressure σ_0 due to an additional load $\Delta\sigma$, is given by :

A. $\Delta H = \frac{C_c H_0}{1 + e_0} \log_{10} \frac{\sigma_0 + \Delta\sigma}{\sigma_0}$

B. $H = \frac{H_0}{1 + e_0} \log_{10} \frac{\sigma_0 + \Delta\sigma}{\sigma_0}$

C. $\Delta H = \frac{C_c H_0}{1 + e_0} \log_{10} \frac{\sigma_0}{\sigma_0 + \Delta\sigma}$

D. $\Delta H = \frac{H_0}{1 + e_0} \log_{10} \frac{\sigma_0}{\sigma_0 + \Delta\sigma}$

Explanation : Refer Q. 3.17, Page 3-19Q, Unit-3.

38. The equation connecting change in void ratio (Δe) due to consolidation (ΔH) of a clay of original thickness H_0 and void ratio e_0 is given by :

A. $\frac{\Delta H}{H_0} = \frac{\Delta e}{1 + e_0}$

B. $\frac{H_0}{\Delta H} = \frac{\Delta e}{1 + e_0}$

C. $\frac{\Delta H}{H_0} = \frac{\Delta e}{e_0}$

D. None of the above

Explanation : Refer Q. 3.17, Page 3-19A, Unit-3.

39. For degree of consolidation U , less than 60%, time factor is given by

A. $\frac{\pi}{2} \left(\frac{U}{100} \right)^2$

B. $\frac{\pi}{4} \left(\frac{U}{100} \right)^2$

C. $\frac{\pi}{4} \left(\frac{U}{100} \right)^3$

D. $\frac{\pi}{2} \left(\frac{U}{100} \right)^3$

Explanation : Refer Q. 3.19, Page 3-22A, Unit-3.

40. Time factor corresponding to 25 % degree of consolidation is given by :

- A. $\frac{\pi}{64}$
- B. $\frac{\pi}{32}$
- C. $\frac{\pi}{16}$
- D. $\frac{\pi}{8}$

Explanation : Refer Q. 3.20, Page 3-23A, Unit-3.

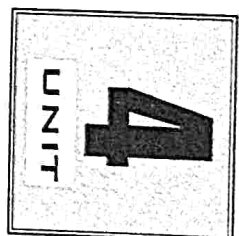

Stress Distribution in Soil and Shear Strength (Multiple Choice Questions)

1. Following are the assumption made in Boussinesq theory. Which one is incorrect ?
 - A. Soil is homogeneous, semi-infinite, elastic and isotropic.
 - B. Self weight of soil is ignored.
 - C. Distribution of stresses is symmetrical about vertical axis.
 - D. Soil is initially stressed.

Explanation : Refer Q. 4.1, Page 4-2A, Unit-4.

2. The stress developed at a point in the soil exactly below the point load at the surface is :
 - A. Proportional to the depth of point.
 - B. Proportional to the square of the depth of point.
 - C. Inversely proportional to the depth of point.
 - D. Inversely proportional to the square of the depth of point.

Explanation : Refer Q. 4.1, Page 4-2A, Unit-4.

3. Boussinesq equation for calculating the vertical stress at a point below ground level is given by :

A. $\sigma_z = \frac{3Q}{2\pi Z^2} \left[\frac{1}{1+(r/Z)^2} \right]^{5/2}$ B. $\sigma_z = \frac{5Q}{2\pi Z^2} \left[\frac{1}{1+(r/Z)^2} \right]^{5/2}$

C. $\sigma_z = \frac{3Q}{2\pi Z^2} \left[\frac{1}{1+(r/Z)^2} \right]^{3/2}$ D. $\sigma_z = \frac{5Q}{2\pi Z^2} \left[\frac{1}{1+(r/Z)^2} \right]^{3/2}$

Explanation : Refer Q. 4.1, Page 4-2A, Unit-4.

4. Consider the Westergaard's analysis for vertical stress, which one is correct :
 - A. Soil is homogeneous, elastic semi-infinite and non isotropic.
 - B. Medium is assumed to be laterally reinforced with numerous closely spaced sheet of negligible thickness.
 - C. Medium is assumed to be horizontally rigid but vertically elastic.
 - D. All of the above

Explanation : Refer Q. 4.1, Page 4-2A, Unit-4.

5. The Westergaard's analysis is used for :
 - A. Homogeneous soils
 - B. Cohesive soils
 - C. Sandy soils
 - D. Stratified soils

Explanation : Refer Q. 4.1, Page 4-2A, Unit-4.

6. Westergaard's equation for vertical pressure is given by :

A. $\sigma_z = \frac{Q}{\pi Z^2} \left[\frac{1}{1+2(r/Z)^2} \right]^{3/2}$ B. $\sigma_z = \frac{Q}{\pi Z^2} \left[\frac{1}{1+2(r/Z)^2} \right]^{3/2}$
 C. $\sigma_z = \frac{2Q}{\pi Z^2} \left[\frac{1}{1+2(r/Z)^2} \right]^{-3/2}$ D. $\sigma_z = \frac{Q}{\pi Z^2} \left[\frac{1}{1+2(r/Z)^2} \right]^{-3/2}$

Explanation : Refer Q. 4.1, Page 4-2A, Unit-4.

7. Consider the following :

- At $r/Z = 0$, Westergaard's value is 67% of Boussinesq's value.
- At $r/Z = 1.5$ both value are equal.
- For $r/Z > 1.5$ Westergaard's stresses are greater.

Which of the following is/are correct ?

- A. Only 1 B. 2 and 3
 C. 3 and 1 D. 1, 2 and 3

Explanation : Refer Q. 4.1, Page 4-2A, Unit-4.

8. The intensity of vertical pressure directly below a concentrated load of Q kN at a depth of Z m in a soil mass is :

- A. $3Q/2\pi Z^2$ B. $\frac{2\pi}{3} QZ^2$
 C. $\frac{3}{2\pi} \times \frac{Q}{Z^3}$ D. $\frac{3}{2\pi} \frac{Q}{Z}$

Explanation : Refer Q. 4.2, Page 4-4A, Unit-4.

9. Considering the vertical stress for a sedimentary soil deposit, which solution is more appropriate ?

- A. Boussinesq's solution B. Westergaard's solution
 C. Approximate method D. None of these

Explanation : Refer Q. 4.6, Page 4-4A, Unit-4.

10. The vertical stress on a centre line at a depth Z of a circular area of radius R carrying UDL intensity q is given by :

A. $q \left[1 - \left(\frac{1}{1+(R/Z)^2} \right)^{3/2} \right]$ B. $q \left[1 - \frac{1}{\left(1 + \frac{R^2}{Z^2} \right)^{3/2}} \right]$
 C. $\frac{q}{Z^2} \left[\frac{1}{1+\left(\frac{R}{Z}\right)^2} \right]^{3/2}$ D. $\frac{3}{2\pi} \frac{q}{Z^2} \left[\frac{1}{1+\left(\frac{R}{Z}\right)^2} \right]^{3/2}$

Explanation : Refer Q. 4.7, Page 4-9A, Unit-4.

11. If the entire semi infinite soil mass is loaded with a load intensity of q at the surface, the vertical stress at any depth Z is equal to :

A. $\sigma_z = \frac{2q}{\pi Z} \left[\frac{1}{1+\left(\frac{x}{Z}\right)^2} \right]^2$ B. 0.5q

C. 0

D. q

Explanation : Refer Q. 4.8, Page 4-11A, Unit-4.

12. For a strip of width B subjected to a load intensity of q on the surface, the vertical stress at a depth Z is :

A. $\sigma_z = \frac{q}{\pi} (2\theta + \tan 2\theta)$ B. $\sigma_z = \frac{q}{\pi} (2\theta + \sin 2\theta)$

C. $\sigma_z = \frac{q}{2\pi} (\theta + \sin \theta)$ D. $\frac{q}{\pi} (\theta + \tan \theta)$

Explanation : Refer Q. 4.8, Page 4-11A, Unit-4.

13. An isobar is a curve which :

- A. Joins points of equal horizontal stress
 B. Joins points of equal vertical stress
 C. Joins points zero vertical stress
 D. Joins points of maximum vertical stress

Explanation : Refer Q. 4.11, Page 4-15A, Unit-4.

14. Consider the isobar :

- Each isobar represents a fraction of the load applied at the surface
- Isobar is also known as pressure bulb
- Normally isobars are drawn for vertical, horizontal and shear stresses

Which of the following is/are correct ?

- A. 1 and 2 B. 2 and 3
 C. 3 and 1 D. 1, 2 and 3

Explanation : Refer Q. 4.11, Page 4-15A, Unit-4.

15. The equation $s = c + \sigma \tan \phi$ is given by,

- A. Rankine B. Coulomb
 C. Newton D. Mohr

Explanation : Refer Q. 4.14, Page 4-18A, Unit-4.

16. The shear strength of a soil

- A. is directly proportional to the angle of internal friction of the soil
 B. is inversely proportional to the angle of internal friction of the soil
 C. Decrease with increase in normal stress

D. Decrease with decrease in normal stress

Explanation : Refer Q. 4.14, Page 4-18A, Unit-1.

17. In a Mohr's diagram a point above Mohr's envelope indicates

- A. Imaginary condition
 B. Safe condition
 C. Imminent failure condition
 D. Condition of maximum obliquity

Explanation : Refer Q. 4.14, Page 4-18A, Unit-4.

18. In a direct shear test the shear stress and normal stress on a dry sand sample of failure are 0.6 kg/cm² and 1 kg/cm², respectively. The angle of internal friction of the sand will be :
 A. 25° B. 31°
 C. 37° D. 43°
Explanation : Refer Q. 4.14, Page 4-18A, Unit-4.
19. Shear failure of soils takes place when :
 A. The angle of obliquity is maximum (Mohr's circle touch the envelope)
 B. Maximum cohesion is reached in cohesive soils
 C. ϕ reaches its maximum value in cohesionless soils
 D. Residual strength of the soil is exhausted.
Explanation : Refer Q. 4.14, Page 4-18A, Unit-4.
20. Which of the following statement are correct for direct shear test?
 A. Test is useful for all types of soil.
 B. Drainage conditions can be fully controlled.
 C. The failure plane is always horizontal.
 D. All of the above.
Explanation : Refer Q. 4.15, Page 4-19A, Unit-4.
21. In direct shear test, proving ring is used to measure :
 A. Displacement B. Shear load
 C. Compressive load D. All of the above
Explanation : Refer Q. 4.15, Page 4-19A, Unit-4.
22. The advantages of direct shear test :
 A. Failure takes place on the predetermined plane.
 B. It is a quick test.
 C. Drainage conditions cannot be changed.
 D. Failure of the sample is progressive.
Explanation : Refer Q. 4.15, Page 4-19A, Unit-4.
23. The direct shear test suffers from following disadvantages :
 A. Drainage conditions cannot be controlled.
 B. Pore water pressure cannot be measured.
 C. Shear stress on the shear plane is not uniform.
 D. All of the above.
Explanation : Refer Q. 4.15, Page 4-19A, Unit-4.
24. Unconfined compression strength test is :
 A. Drained test
 B. Undrained test
 C. Consolidation undrained test
 D. Unconsolidated drained test
Explanation : Refer Q. 4.17, Page 4-21A, Unit-4.

25. An unconfined compression test is a special case of :
 A. Direct shear test B. Triaxial compression test
 C. Vane shear test D. None of the above
Explanation : Refer Q. 4.17, Page 4-21A, Unit-4.
26. In situ vane shear test is conducted to determine the shear strength of :
 A. Cohesive soil B. Non cohesive soil
 C. Silty soil D. Sandy soil
Explanation : Refer Q. 4.18, Page 4-22A, Unit-4.
27. According to vane shear test the shear strength (s) of soil is given by,
 A. $\frac{T}{\pi \left[\frac{D^2 H}{2} + \frac{D^3}{6} \right]}$ B. $\frac{T}{\pi \left[\frac{D^2 H}{2} - \frac{D^3}{6} \right]}$
 C. $\frac{T\pi}{\left[\frac{D^2 H}{2} - \frac{D^3}{6} \right]}$ D. $\frac{T}{\pi \left[\frac{D^2 H}{2} + \frac{D^3}{6} \right]}$
Explanation : Refer Q. 4.18, Page 4-22A, Unit-4.
28. Drained conditions are properly controlled in :
 A. Vane shear test B. Direct shear test
 C. Triaxial shear test D. None of these
Explanation : Refer Q. 4.19, Page 4-22A, Unit-4.
29. When drainage is permitted throughout the triaxial test, the test is known as :
 A. Quick test B. Drained test
 C. Consolidated undrained test
 D. None of the above
Explanation : Refer Q. 4.20, Page 4-23A, Unit-4.
30. In a triaxial test, if drainage is allowed during the first stage of test (during application of cell pressure) alone, and is prevented during the second stage (during application of deviator load), then the test may known as :
 A. Unconsolidated undrained test
 B. Consolidated undrained test
 C. Unconsolidated drained test
 D. Consolidated drained test
Explanation : Refer Q. 4.20, Page 4-23A, Unit-4.
31. In a triaxial test, if a test is performed without allowing drainage during the initial application of cell pressure but the same is allowed during the second stage of application of deviator load, the test may be termed as :
 A. Unconsolidated undrained test

- B. Consolidated undrained test
 - C. Unconsolidated drained test
 - D. Consolidated drained test
- Explanation : Refer Q. 4.20, Page 4-23A, Unit-4.

32. In the consolidated drained test on a saturated soil sample, pore water pressure is zero during :

- A. Consolidation stage only
- B. Shearing stage only
- C. Both consolidation and shearing stages
- D. Loading stage

Explanation : Refer Q. 4.20, Page 4-23A, Unit-4.

33. In a fully saturated soil Skempton's pore pressure parameter B becomes equal to :

- A. 0
- B. 0.5
- C. 1
- D. 0.75

Explanation : Refer Q. 4.22, Page 4-27A, Unit-4.

34. The ratio of change in pore pressure to the change in deviator stress is called :

- A. B-factor
- B. A-factor
- C. Over consolidation ratio
- D. None of the above

Explanation : Refer Q. 4.22, Page 4-27A, Unit-4.

35. The ratio of change in pore pressure with the change in the cell pressure is called :

- A. B-factor
- B. A-factor
- C. Over consolidation ratio
- D. None of the above

Explanation : Refer Q. 4.22, Page 4-27A, Unit-4.

36. In a triaxial test the deviator stress is given by :

- A. $\sigma_1 + \sigma_3$
- B. $\frac{\sigma_1 + \sigma_3}{2}$
- C. $\sigma_1 - \sigma_3$
- D. $\frac{\sigma_1 - \sigma_3}{2}$

Explanation : Refer Q. 4.24, Page 4-30A, Unit-4.

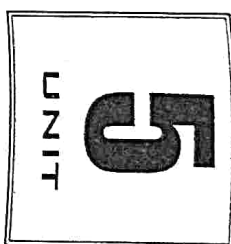

Earth Pressure and Stability of Slopes

(Multiple Choice Questions)

1. Active earth pressure of a soil is defined as the lateral pressure exerted by the soil when :

- A. The retaining wall is at rest
- B. The retaining wall tends to move away from the backfill
- C. The retaining wall moves in the soil
- D. None of the above

Explanation : Refer Q. 5.1, Page 5-2A, Unit-5.

2. Coefficient of active earth pressure for cohesionless soils is given by :

- A. $\frac{1 + \sin \phi}{1 - \sin \phi}$
- B. $\frac{1 - \sin \phi}{1 + \sin \phi}$
- C. $\frac{1 + \tan \phi}{1 - \tan \phi}$
- D. $\frac{1 + \cos \phi}{1 - \cos \phi}$

Explanation : Refer Q. 5.2, Page 5-3A, Unit-5.

3. Rankine's theory of earth pressure assumes that the back of the wall is :

- A. Plane and smooth
 - B. Plane and rough
 - C. Vertical and smooth
 - D. Vertical and rough
- Explanation : Refer Q. 5.2, Page 5-3A, Unit-5.

4. Following are the assumptions of Rankine's theory of earth pressure :

1. The soil mass is homogeneous and semi infinite.
2. The ground surface is plane, which may be horizontal and inclined.
3. The soil is dry and cohesionless.

- A. 1 and 2
- B. 2 and 3
- C. 1 and 3
- D. 1, 2 and 3

Explanation : Refer Q. 5.2, Page 5-3A, Unit-5.

5. As angle of internal friction ϕ increases, coefficient of active earth pressure :

- A. Increases
 - B. Decreases
 - C. Remains same
 - D. None of the above
- Explanation : Refer Q. 5.2, Page 5-3A, Unit-5.

MCQ-28 A (CE-Sem-5)

Multiple Choice Questions

6. The correct sequence of the given parameters in descending order of earth pressure intensity is :
 A. Active, Passive, At rest B. Passive, Active, At rest
 C. Passive, At rest, Active D. At rest, Passive, Active
Explanation : Refer Q. 5.3, 2 Marks, Page SQ-14A, Unit-5.
7. Depth below the ground surface, where active earth pressure intensity is zero, is given by :
 A. $\frac{2c\sqrt{K_a}}{\gamma}$ B. $\frac{2c}{\sqrt{K_a}}$
 C. $\frac{2c}{\gamma\sqrt{K_a}}$ D. $\frac{2c-\gamma}{K_a}$
Explanation : Refer Q. 5.3, Page 5-6A, Unit-5.
8. According to Rankine's theory, the active earth pressure at the base level of excavation in the cohesive soil is :
 A. $P_a = K_a \gamma - 2c\sqrt{K_a}H$ B. $P_a = K_a \gamma H - 2c\sqrt{K_a}$
 C. $P_a = \frac{K_a \gamma}{H} - 2c\sqrt{K_a}$ D. $P_a = k_a H - \frac{2c}{\sqrt{K_a}}$
Explanation : Refer Q. 5.3, Page 5-5A, Unit-5.
9. To have zero active earth pressure intensity at the top of a wall in cohesive soil, the required intensity of uniform surcharge is :
 A. $2c \cot \alpha$ B. $2c \tan \alpha$
 C. $-2c \cot \alpha$ D. $-2c \tan \alpha$
Explanation : Refer Q. 5.3, Page 5-5A, Unit-5.
10. The angle of internal friction ϕ for cohesive soils is equal to
 A. 0° B. 30°
 C. 45° D. 90°
Explanation : Refer Q. 5.3, Page 5-5A, Unit-5.
11. Passive earth pressure in a soil mass is proportional to
 A. $\tan^2 \left(45 + \frac{\phi}{2} \right)$ B. $\cot^2 \left(45 - \frac{\phi}{2} \right)$
 C. $\tan^2 \left(45 - \frac{\phi}{2} \right)$ D. $\cot^2 \left(45 + \frac{\phi}{2} \right)$
Explanation : Refer Q. 5.3, 2 Marks, Page SQ-14A, Unit-5.
12. For a sand having an internal friction of 30° , the ratio of passive to active lateral earth pressure will be :
 A. 1 B. 2
 C. 9 D. 12
Explanation : Refer Q. 5.3, 2 Marks, Page SQ-14A, Unit-5.

Geotechnical Engineering

MCQ-29 A (CE-Sem-5)

13. Coulomb's theory of earth pressure is based on
 A. The theory of elasticity B. Empirical rules
 C. Wedge theory D. The theory of plasticity
Explanation : Refer Q. 5.5, Page 5-8A, Unit-5.
14. Preferable back fill material behind a retaining wall is
 A. Silt B. Sand
 C. Clay D. Peat
Explanation : Refer Q. 5.5, Page 5-8A, Unit-5.
15. Following are the assumptions of Coulomb wedge theory :
 1. The failure wedge acts as rigid body and stresses are uniformly distributed over it.
 2. Failure is two dimensional and rupture surface is plane which passes through the heel of the wall.
 3. Location and direction of resultant thrust is known.
 A. 1 and 2 B. 2 and 3
 C. 1 and 3 D. 1, 2 and 3
Explanation : Refer Q. 5.5, Page 5-8A, Unit-5.
16. Which one is general theory of lateral earth pressure ?
 A. Rankine's theory
 B. Coulomb's theory
 C. Both Coulomb's and Rankine's theory
 D. None of the above
Explanation : Refer Q. 5.5, Page 5-8A, Unit-5.
17. According to Coulomb's wedge theory, in the active earth pressure case the wedge slide :
 A. Downward and outward on a slip surface
 B. Horizontally inward parallel of base.
 C. Upward and inward on a slip surface.
 D. None of the above.
Explanation : Refer Q. 5.5, Page 5-8A, Unit-5.
18. According to Coulomb's wedge theory, in the passive case the wedge slide :
 A. Horizontally and outward parallel of base.
 B. Downward and outward on a slip surface.
 C. Upward and inward on a slip surface.
 D. None of the above.
Explanation : Refer Q. 5.5, Page 5-8A, Unit-5.
19. Which is/are the factor(s) affecting of coefficient of earth pressure ?
 A. The angle of back of soil B. The soil-wall friction value
 C. The angle of backfill D. All of the above
Explanation : Refer Q. 5.6, 2 Marks, Page SQ-15A, Unit-5.

MCQ-30 A (CE-Sem-5)

Multiple Choice Questions

20. The _____ is an unsupported inclined surface of a soil mass.
 A. Slope
 B. Embankment
 C. Foundation
 D. None of the above
Explanation : Refer Q. 5.7, 2 Marks, Page SQ-15A, Unit-5.
21. Slope are generally provide for :
 A. Highway and Railway formations
 B. Earth dams
 C. Canal banks and levees
 D. All of the above
Explanation : Refer Q. 5.7, 2 Marks, Page SQ-15A, Unit-5.
22. The total lateral earth pressure is proportional to :
 A. Depth of soil
 B. Square of the depth of soil
 C. Angle of internal friction of soil
 D. None of the above
Explanation : Refer Q. 5.9, Page 5-12A, Unit-5.
23. Which is/are examples of an artificial slopes ?
 A. The sides of cuttings.
 B. The slopes of earth dams.
 C. The slopes of embankments of road, canal, railway lines, etc.
 D. All of the above.
Explanation : Refer Q. 5.10, Page 5-13A, Unit-5.
24. The slopes made up of soil which has both frictional as well as cohesive properties, the slope is known as :
 A. Cohesive soil slope
 B. Frictional soil slope
 C. Cohesive-frictional soil slope
 D. None of the above
Explanation : Refer Q. 5.10, Page 5-13A, Unit-5.
25. Which one is the example of natural slope ?
 A. Slope in hilly areas
 B. Slope of earth dam
 C. Sides of embankment and cutting
 D. All of the above
Explanation : Refer Q. 5.10, Page 5-13A, Unit-5.
26. Factor of safety with respect to shear strength is given by,
 A. $\frac{c}{c_d}$
 B. $\frac{s}{\tau_d}$
 C. $\frac{\tan \phi}{\tan \phi_d}$
 D. None of the above
Explanation : Refer Q. 5.12, Page 5-14A, Unit-5.
27. Failure of finite slopes takes place due to :
 A. Translational
 B. Compound

Geotechnical Engineering

MCQ-31 A (CE-Sem-5)

- C. Wedge
Explanation : Refer Q. 5.12, Page 5-14A, Unit-5.
- D. Rotation
Explanation : Refer Q. 5.12, Page 5-14A, Unit-5.
28. Factor of safety of slopes with respect to angle of internal friction is given by,
 A. $\frac{\tan \phi}{\tan \phi_d}$
 B. $\frac{c}{c_d}$
 C. $\frac{s}{\tau_d}$
 D. None of these
Explanation : Refer Q. 5.12, Page 5-14A, Unit-5.
29. A failure along an inclined plane is known as :
 A. Rotational failure
 B. Translational failure
 C. Compound failure
 D. Wedge failure
Explanation : Refer Q. 5.14, Page 5-17A, Unit-5.
30. A type of failure occurs by rotation along a slip surface by downward and outward movement of the soil mass is :
 A. Wedge failure,
 B. Compound failure
 C. Rotational failure
 D. Miscellaneous failure.
Explanation : Refer Q. 5.14, Page 5-17A, Unit-5.
31. The slip surface for homogeneous soil is :
 A. Plane
 B. Circular
 C. Irregular
 D. All of the above
Explanation : Refer Q. 5.14, Page 5-17A, Unit-5.
32. Base failure of a finite slope :
 A. Occurs when soil below the level of toe is strong.
 B. Occurs when there is a relatively weak zone in upper part of the slope.
 C. Occurs when the soil below the toe is relatively soft and weak.
 D. Is a most common failure and occurs in relatively steep slope.
Explanation : Refer Q. 5.14, Page 5-17A, Unit-5.
33. In stability analysis, the term mobilized shear strength is equal to :
 A. Shear strength
 B. Maximum shear strength
 C. Applied shear stress
 D. All of the above
Explanation : Refer Q. 5.15, Page 5-38A, Unit-5.
34. The ratio of the available cohesion intercept (c) and the mobilized cohesion intercept (c_m) is known as factor of safety with respect to :
 A. Shear strength
 B. Friction
 C. Cohesion
 D. None of the above
Explanation : Refer Q. 5.15, Page 5-18A, Unit-5.

35. The stability of a slope is increased by :
- Slope flattening.
 - Consolidation by surcharging.
 - Grouting and injection of cement or other compounds.
 - All of the above.

Explanation : Refer Q. 5.16, 2 Marks, Page SQ-16A, Unit-5.

36. The method of slice for the stability of slope can be used :
- For stratified soil.
 - When seepage occurs and the pore pressure exists within the soil.
 - Both (A) and (B).
 - None of the above.

Explanation : Refer Q. 5.17, Page 5-21A, Unit-5.

37. According to Swedish circle method, factor of safety against sliding is expressed as :

A. $F = \frac{cL + \tan \phi' \Sigma W \cos \alpha}{\Sigma W \sin \alpha}$ B. $F = \frac{cL - \tan \phi' \Sigma W \cos \alpha}{\Sigma W \sin \alpha}$

C. $F = \frac{cL + \cot \phi \Sigma W \cos \alpha}{\Sigma W \sin \alpha}$ D. None of the above

Explanation : Refer Q. 5.17, Page 5-21A, Unit-5.

38. Taylor's stability charts are based on the total stresses using the

- Friction circle method
- Method of slices
- Bishop's method
- None of the above

Explanation : Refer Q. 5.19, Page 5-24A, Unit-5.

39. Taylor's stability number (S_n) is given by,

A. $\frac{c}{F_c \gamma H}$

B. $\frac{\gamma H}{c F_c}$

C. $F_c \frac{c}{\gamma H}$

D. $F_c \frac{\gamma H}{c}$

Explanation : Refer Q. 5.19, Page 5-24A, Unit-5.

40. Consider the following about stability numbers :

- This dimensionless number is proportional to the required cohesion and is inversely proportional to the allowable height.
- The reciprocal of the stability number is known as stability factor.

- Only 1 is correct
- Only 2 is correct
- Both 1 and 2 are correct
- None of the above.

Explanation : Refer Q. 5.19, Page 5-24A, Unit-5.

